

Available executions

Execution No.	Material ID	Cylinder No.
1	PAAD327122	6-9

SURFACE PROTECTION SEE GROUP 0344  
 TOLERANCING PRINCIPLE ISO8015  
 GENERAL TOLERANCES ACCORDING TO ISO2768-mK

**NOTE**

The above executions can be configured using the Engine Configurator. Detailed guidance for the executions is provided within the Marine Installation Manual (MIM). If a specific execution of interest is not shown in the above table, then it may still be under development or not available. For further information or in case of a project-specific request, WinGD must be contacted directly.

This publication is designed to provide accurate and authoritative information with regard to the subject-matter covered as it was available at the time of printing. However, the publication deals with complicated technical matters suited only for specialists in the area, and the design of the subject-products is subject to regular improvements, modifications and changes. Consequently, the publisher and copyright owner of this publication cannot accept any responsibility or liability for any eventual errors or omissions in this document or for discrepancies arising from the features of any actual item in the respective product being different from those shown in this publication. The publisher and copyright owner shall under no circumstances be held liable for any financial consequential damages or other loss, or any other damage or injury, suffered by any party making use of this publication or the information contained herein.

Prod.	X82-2.0										
Change History											
	-	sde101	dst009	27.10.2021	CNAA000871	new Design				-	-
	Rev.	Creator	Approver	Approval Date	Change ID	Change Synopsis	Approved	Activity Code	E	C	



AIR SUPPLY SYSTEM  
 MIDS master drawing

separate BOM available

Dimension

Scale	-		NX	Units [mm] [kg]	Basic Material	Net Weight	0.001		
Copyright Winterthur Gas & Diesel Ltd. All rights reserved. By taking possession of the drawing the recipient recognizes and honours these rights. Neither the whole nor any part of this drawing may be used in any way for construction, fabrication, marketing or any other purpose nor copied in any way nor made accessible to third parties without the previous written consent of Winterthur Gas & Diesel Ltd.				Main Design	Design Group	9725	Q-Code XXXXX	Standard	WDS
Qty per	A4	Item ID	PTAA015293			Drawing Page/s	1/1		

SEQ NO	QTY	Item ID	Item Name	Dimension	Standard-ID	Basic Material	Net Weight
1	1	PTAA011044	AIR SUPPLY SYSTEM				0.001

--	--	--	--	--	--	--	--

Prod.	6,7,8,9 X82-2.0						
Change History							
	A	sde101	dst009	27.10.2021	CNAA000871	Main Design/Drawing Introduced	4 3
	-	dki021	mhu019	02.07.2019		-	- -
	Rev.	Creator	Approver	Approval Date	Change ID	Change Synopsis	Activity Code E C

	AIR SUPPLY SYSTEM
--	-------------------

<b>Bill Of Material</b>		Dimension					
Copyright Winterthur Gas & Diesel Ltd. All rights reserved. By taking possession of the document the recipient recognizes and honours these rights. Neither the whole nor any part of this document may be used in any way for construction, fabrication, marketing or any other purpose nor copied in any way nor made accessible to third parties without the previous written consent of Winterthur Gas & Diesel Ltd.	Units	[m] [kg]	Basic Material			Net Weight	0.001
	Main Design	Yes	Design Group	9725	Q-Code	XXXXX	Standard WDS
	Qty per	Engine	A4	Item ID	PAAD327122		BOM Page/s

DRIVING END

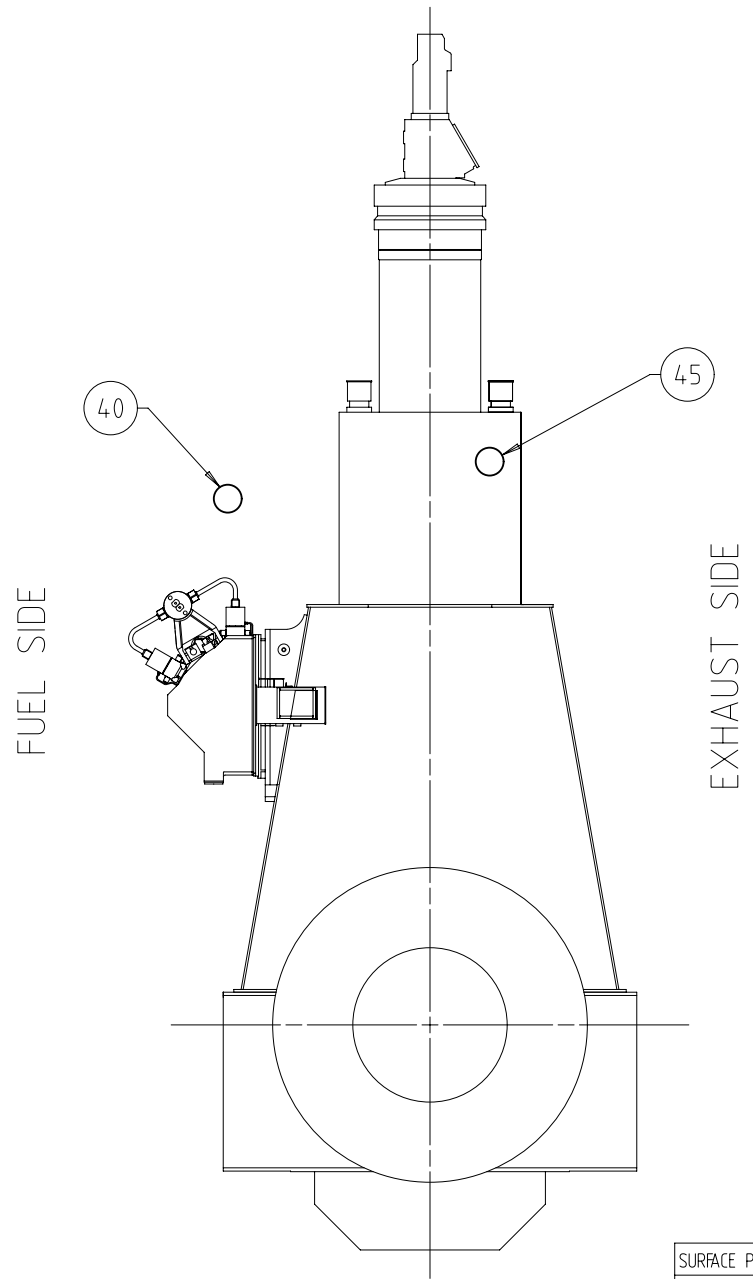

SPECIFICATIONS which must be met

40	INLET - Starting air Starting air pressure: 25 or 30 bar (according to design) Capacity of starting air receivers: according to GTD
45	INLET - Control air Control air pressure: 7-9 bar Control air quality has to be comply with the compressed air purity class: 5-4-3 according to ISO 8573-1 (2010-04-15)

Prod.														
Change History	-	sde101	dst009	27.10.2021	CNA000871	new Design					-	-		
	Rev.	Creator	Approver	Approval Date	Change ID	Change Synopsis					Approved	Activity Code	E	C
					AIR SUPPLY SYSTEM									
Dimension														
Scale	-		NX	Units [mm] [kg]	Basic Material					Net Weight	0.001			
SURFACE PROTECTION SEE GROUP 0344 TOLERANCING PRINCIPLE ISO8015 GENERAL TOLERANCES ACCORDING TO ISO2768-mK				Copyright Winterthur Gas & Diesel Ltd. All rights reserved. By taking possession of the drawing the recipient recognizes and honours these rights. Neither the whole nor any part of this drawing may be used in any way for construction, fabrication, marketing or any other purpose nor copied in any way nor made accessible to third parties without the previous written consent of Winterthur Gas & Diesel Ltd.				Main Design	Design Group	9725	Q-Code	XXXXX	Standard	WDS
Qty per	A3		Item ID	PTAA011044					Drawing Page/s	1/2				



## WinGD X82-2.0 – Air Supply System (DG9725)

### TRACK CHANGES

DATE	SUBJECT	DESCRIPTION
2019-07-12	DRAWING SET	First web upload
2021-12-21	PAAD327122 PAAD327122	Main and system drg – new revision

### DISCLAIMER

© Copyright by Winterthur Gas & Diesel Ltd.

All rights reserved. No part of this document may be reproduced or copied in any form or by any means (electronic, mechanical, graphic, photocopying, recording, taping or other information retrieval systems) without the prior written permission of the copyright owner.

THIS PUBLICATION IS DESIGNED TO PROVIDE AN ACCURATE AND AUTHORITATIVE INFORMATION WITH REGARD TO THE SUBJECT-MATTER COVERED AS WAS AVAILABLE AT THE TIME OF PRINTING. HOWEVER, THE PUBLICATION DEALS WITH COMPLICATED TECHNICAL MATTERS SUITED ONLY FOR SPECIALISTS IN THE AREA, AND THE DESIGN OF THE SUBJECT-PRODUCTS IS SUBJECT TO REGULAR IMPROVEMENTS, MODIFICATIONS AND CHANGES. CONSEQUENTLY, THE PUBLISHER AND COPYRIGHT OWNER OF THIS PUBLICATION CAN NOT ACCEPT ANY RESPONSIBILITY OR LIABILITY FOR ANY EVENTUAL ERRORS OR OMISSIONS IN THIS BOOKLET OR FOR DISCREPANCIES ARISING FROM THE FEATURES OF ANY ACTUAL ITEM IN THE RESPECTIVE PRODUCT BEING DIFFERENT FROM THOSE SHOWN IN THIS PUBLICATION. THE PUBLISHER AND COPYRIGHT OWNER SHALL UNDER NO CIRCUMSTANCES BE HELD LIABLE FOR ANY FINANCIAL CONSEQUENTIAL DAMAGES OR OTHER LOSS, OR ANY OTHER DAMAGE OR INJURY, SUFFERED BY ANY PARTY MAKING USE OF THIS PUBLICATION OR THE INFORMATION CONTAINED HEREIN.