

1 2 3 4 5 6 7 8

A
B
C
D
E
F

A
B
C
D
E
F

Net Weight		0,001						
Quantity	SEQ NO	Material ID	Material Name	Dimension, Occ	Standard or Drawing	Basic Material Material Standard	Weight GR./NET	
1	001	PAAD379236	AIR SUPPLY SYSTEM		DAAD142347		0,001	
PER ENGINE	Free space for lic.						Q-Code XXXXXX	Main Drw. H
Material ID	Modif.	Number	Drawn date	Number	Drawn date	Number	Drawn date	
PAAD379252	○			○		○		
		Product W5-8X52DF-S1.0		AIR SUPPLY SYSTEM Luftversorgungssystem				
Units	mm kg	NX		Basic Material			Net Weight	
SURFACE PROTECTION SEE GROUP 0344		Made	07.04.2021 dki021 DH.Kim		Scale	-		
TOLERANCING PRINCIPLE ISO8015		Chkd	26.04.2021 jpi101 Pickup		Design Group	9725		
GENERAL TOLERANCES ACCORDING TO ISO2768-mK		Appd	26.04.2021 mhu019 Hug		Drawing ID	DAAD142362		
					Page	1/1		
					Material ID			
					Rev.	-		

Approved
DIP - DIMENSIONAL DRAWING - Confidential

X52-S2.0
X52DF-S1.0

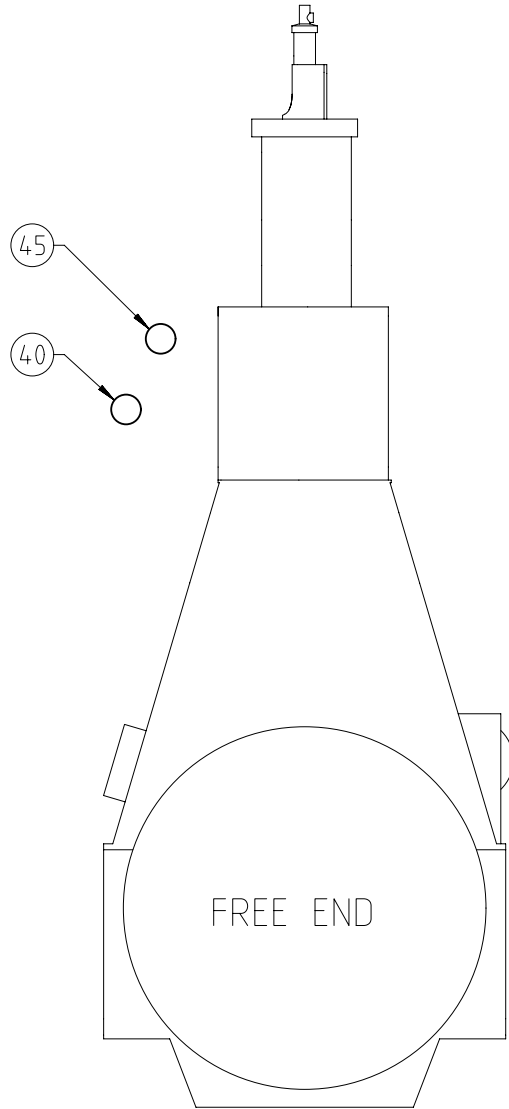

SPECIFICATION which must be met:

(40)	INLET - Starting air Starting air pressure: 25 or 30 bar (according to design) Capacity of starting air receivers: according to GTD
(45)	INLET - Control air Control air pressure: 7-9 bar Control air quality has to be comply with the compressed air purity class: 5-4-3 according to ISO 8573-1(2010-04-15)

Free space for lic.								Q-Code XXXXXX	Main Drw.				
								Standard ISO; JIS					
Modif.	○		○		○		○						
	Number	Drawn date	Number	Drawn date	Number	Drawn date	Number	Drawn date					
 WIN GD Winterthur Gas & Diesel		Product 5-8X52-S2.0 5-8X52DF-S1.0		AIR SUPPLY SYSTEM Luftversorgungssystem									
		Units	mm kg	NX	Basic Material			Net Weight 0,001					
SURFACE PROTECTION SEE GROUP 0344		Made	07.04.2021 dki021 DH.Kim		Scale	-	Size	A3	Page	1/2	Material ID	PAAD379236	
TOLERANCING PRINCIPLE ISO8015		Chkd	26.04.2021 jpi101 Pickup		Design Group		9725		Drawing ID		DAAD142347	Rev.	-
GENERAL TOLERANCES ACCORDING TO ISO2768-mK		Appd	26.04.2021 mhu019 Hug										

DID - DIMENSIONAL DRAWING - Confidential

STARTING AND CONTROL AIR SYSTEM

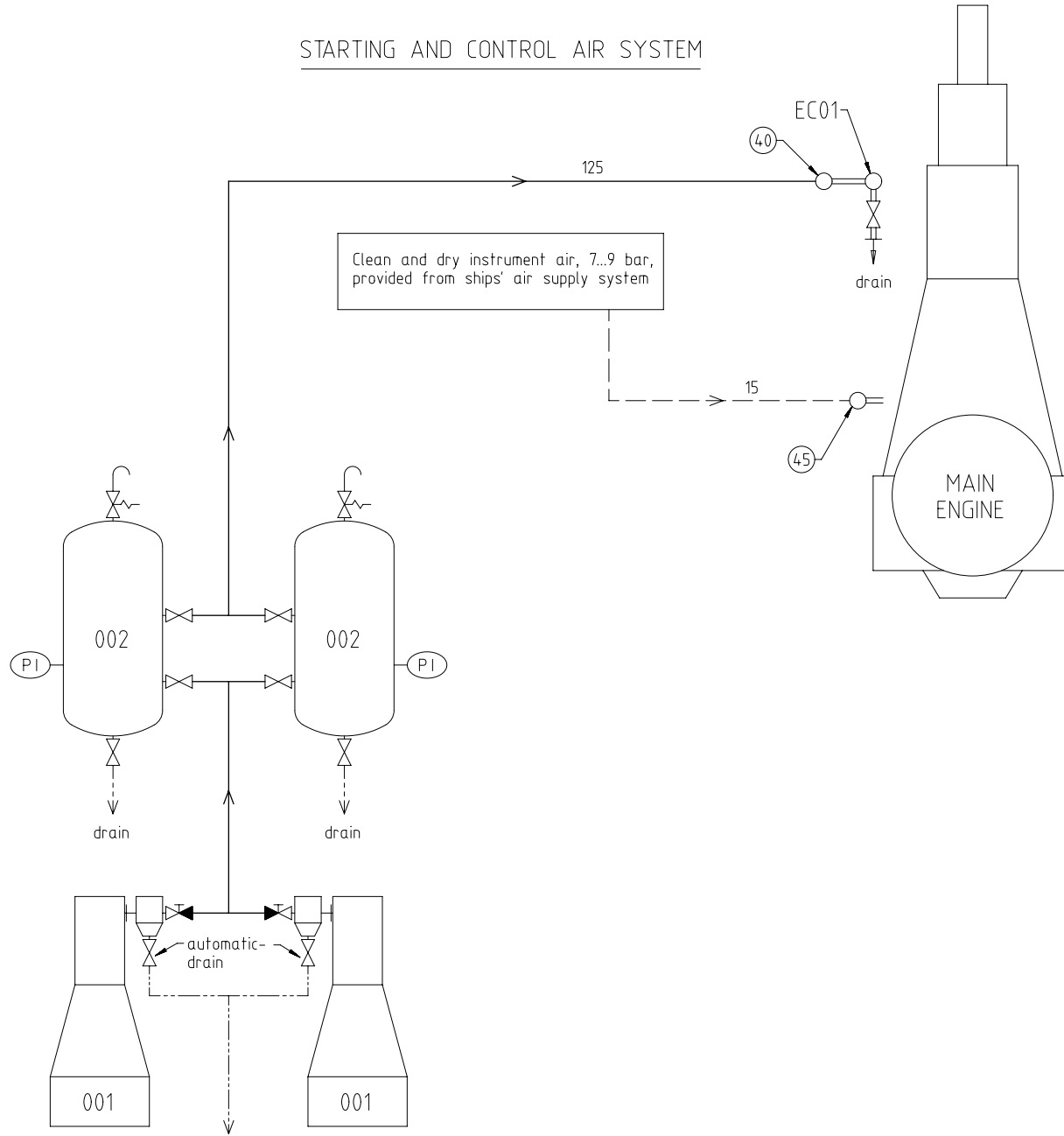

Pos.	System Components *1)
001	Starting air compressor 25/30 bar (capacity according to GTD)
002	Starting air receiver 25/30 bar (capacity according to GTD)

Pos.	Engine Connections *2)
④0	INLET - Starting air
④5	INLET - Control air (for control system and air spring)

Pos.	Engine Components *3)
EC01	Distribution pipe with automatic starting air shut-off valve

Remarks:

- Drain plugs and drain cocks to be installed where necessary.
- Pipe diameters for starting air compressors and auxiliary equipment according to suppliers recommendations.

- *1) Refer to the "Pipe Connection Plan" for the execution and location of the engine pipe connections.
- *2) To be delivered by external supplier and to be installed by the shipyard.
- *3) To be delivered by the engine builder, i.e. already equipped on engine side.

- Starting air feed pipes
- - - Control air pipes
- Ancillary equipment pipes
- - - - Drain pipes
- ==== Pipes on engine
- Pipe connections

Free space for ill.	Q-Code XXXXX						Main Drw.	
	Standard ISO; JIS							
Modif.	Number	Drawn date	Number	Drawn date	Number	Drawn date	Number	Drawn date
		Product 5-8X52-S2.0 5-8X52DF-S1.0		AIR SUPPLY SYSTEM Luftversorgungssystem		Net Weight 0,001		
SURFACE PROTECTION SEE GROUP 034.4		Made 07.04.2021 dki021 DH.Kim		Scale -		Size A2 Page 2/2		
TOLERANCING PRINCIPLE ISO8015		Chkd 26.04.2021 jpr101 Pickup		Design Group 9725		Material ID PAAD379236		
GENERAL TOLERANCES ACCORDING TO ISO2768-mK		Appd 26.04.2021 mhu019 Hug		Drawing ID DAAD142347		Rev. -		

MIDS - WinGD X52DF-S1.0 – Air Supply System (DG9725)

TRACK CHANGES

DATE	SUBJECT	DESCRIPTION
2021-05-10	DRAWING SET	First web upload

DISCLAIMER

© Copyright by Winterthur Gas & Diesel Ltd.

All rights reserved. No part of this document may be reproduced or copied in any form or by any means (electronic, mechanical, graphic, photocopying, recording, taping or other information retrieval systems) without the prior written permission of the copyright owner.

THIS PUBLICATION IS DESIGNED TO PROVIDE AN ACCURATE AND AUTHORITATIVE INFORMATION WITH REGARD TO THE SUBJECT-MATTER COVERED AS WAS AVAILABLE AT THE TIME OF PRINTING. HOWEVER, THE PUBLICATION DEALS WITH COMPLICATED TECHNICAL MATTERS SUITED ONLY FOR SPECIALISTS IN THE AREA, AND THE DESIGN OF THE SUBJECT-PRODUCTS IS SUBJECT TO REGULAR IMPROVEMENTS, MODIFICATIONS AND CHANGES. CONSEQUENTLY, THE PUBLISHER AND COPYRIGHT OWNER OF THIS PUBLICATION CAN NOT ACCEPT ANY RESPONSIBILITY OR LIABILITY FOR ANY EVENTUAL ERRORS OR OMISSIONS IN THIS BOOKLET OR FOR DISCREPANCIES ARISING FROM THE FEATURES OF ANY ACTUAL ITEM IN THE RESPECTIVE PRODUCT BEING DIFFERENT FROM THOSE SHOWN IN THIS PUBLICATION. THE PUBLISHER AND COPYRIGHT OWNER SHALL UNDER NO CIRCUMSTANCES BE HELD LIABLE FOR ANY FINANCIAL CONSEQUENTIAL DAMAGES OR OTHER LOSS, OR ANY OTHER DAMAGE OR INJURY, SUFFERED BY ANY PARTY MAKING USE OF THIS PUBLICATION OR THE INFORMATION CONTAINED HEREIN.