

1 2 3 4 5 6 7 8

A
B
C
D
E
F

SCR	Without		X
	LP SCR	X	

Net Weight		0,001		0,001		
1	1	001	PAAD283786	Exhaust System with one turbocharger	DAAD096529	0,001
Quantity PER ENGINE	SEQ NO	Material ID	Material Name	Standard or Drawing	Basic Material Material Standard	Weight GR./NET

PAAD284286	PAAD284285	Free space for litc.	Q-Code XXXXXX				Main Drw. H
			Standard ISO; JIS				
Material ID	Modif.	Number	Drawn date	Number	Drawn date	Number	Drawn date

	Product W5-8X40-B	Exhaust System Abgassystem
	Units mm kg	NX

SURFACE PROTECTION SEE GROUP 0344	Made	06.03.2018 dki021 DH.Kim	Scale	-	Size	A3	Page	1/1	Material ID	
TOLERANCING PRINCIPLE ISO8015	Chkd	20.04.2018 wwa008 Wang	Design Group	9726	Drawing ID	DAAD096532		Rev.	-	
GENERAL TOLERANCES ACCORDING TO ISO2768-mK	Appd	20.04.2018 mhu019 Hug								

Approved

DID - DIMENSIONAL DRAWING - Confidential

Specifications which must be met:

- 72** OUTLET - Exhaust gas by-pass
- The installation of a by-pass line between exhaust gas manifold and turbocharger may be requested by owner and class if only one turbocharger is installed. Its purpose is to allow engine operation even after a turbocharger failure.
 - Blinded off during normal operation.
- 73** OUTLET - Exhaust gas manifold waste gate
- Size and layout of connection flange is provided in the "Pipe Connection Plan"
 - Pipe diameter according to parameter "B" on page 2.
 - Waste gate connection pipe to main exhaust gas pipe must be kept as short as possible to avoid swirl and extensive back pressure.

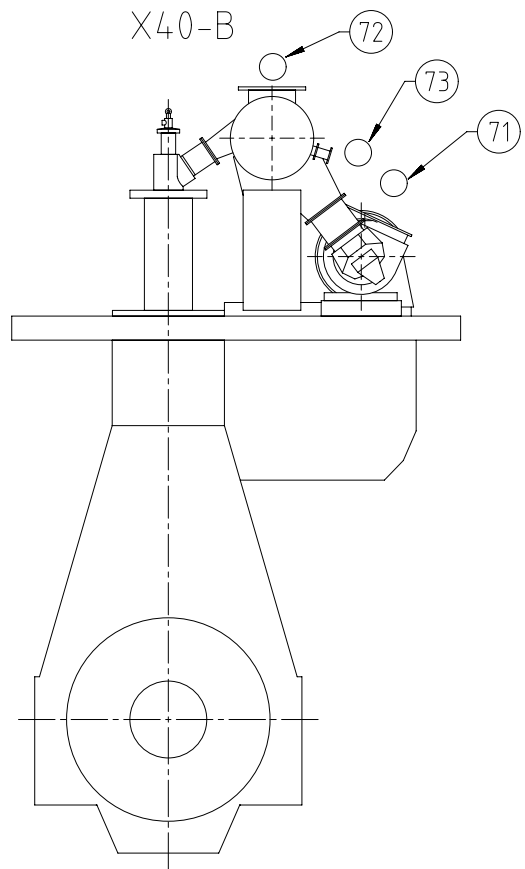

- 71** OUTLET - Exhaust gas turbocharger
- Exhaust gas temperature and volume flow: according to GTD
 - The total back pressure of the exhaust gas system must be kept in the admissible range of:
Design maximum (new condition) without exhaust gas treatment system: 30 mbar
Design maximum (new condition) with exhaust gas treatment system: 60 mbar
 - Operational maximum (fouled condition) without exhaust gas treatment system: 50 mbar
Operational maximum (fouled condition) with exhaust gas treatment system: 80 mbar
 - Pipe dimensions laid out according to the recommended gas velocities provided in the the Marine Installation Manual (MIM) and by GTD.
 - The exhaust piping must be arranged in a way to avoid gases from accumulating.
 - The piping layout must consider the thermal expansion and vibration from turbocharger (TC) and main engine (ME).
Thermal expansion of the ME to be calculated according to the formula in MIM, TC specific thermal expansion are provided by the TC supplier.
 - Supports (fixation points) for carrying piping and exhaust gas system components deadweight must be installed in sufficient size and amount. Inadmissible tensions in the piping and forces acting on the turbocharger are not acceptable.
 - Exhaust gas pipes of several engines must not be connected.
 - Drains in adequate size and amount must be installed in the exhaust gas piping.
 - When the noise level on the bridge wing exceeds the class requirement (normally 60 - 70 dB(A)) a silencer must be applied.

Free space for lic.							Q-Code XXXXXX	Main Drw.						
							Standard ISO; JIS							
Modif.	A	EAAD089374	11.05.2018	B	EAAD090105	11.01.2019	C	EAAD090535	05.04.2019					
		Number	Drawn date		Number	Drawn date		Number	Drawn date	Number	Drawn date			
		Product 5-8X40-B		Exhaust System with one turbocharger										
Units	mm kg	NX		Basic Material				Net Weight 0,001						
SURFACE PROTECTION SEE GROUP 0344		Made	23.01.2018	dk1021	DH.Kim		Scale	-	Size	A3	Page	1/2	Material ID	PAAD283786
TOLERANCING PRINCIPLE ISO8015		Chkd	14.02.2018	wva008 Wang		Design Group		9726		Drawing ID		DAAD096529	Rev.	C
GENERAL TOLERANCES ACCORDING TO ISO2768-mK		Appd	28.02.2018	mhu019 Hug										

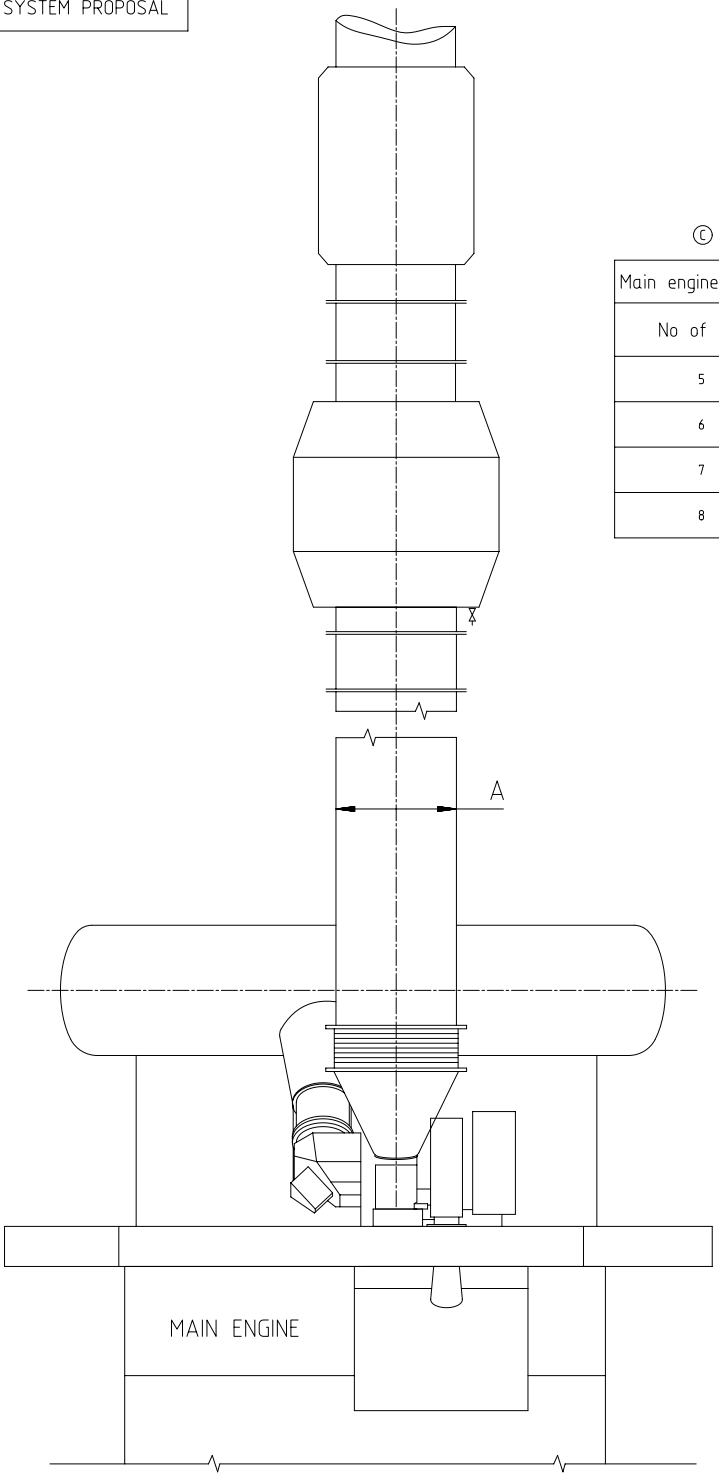

Ⓒ

Main engine X4.0-B			
No of cyl.	A (mm) *13	B (mm) *9	C (mm) *13
5	800	100	350
6	900	100	350
7	900	125	350
8	1000	125	350

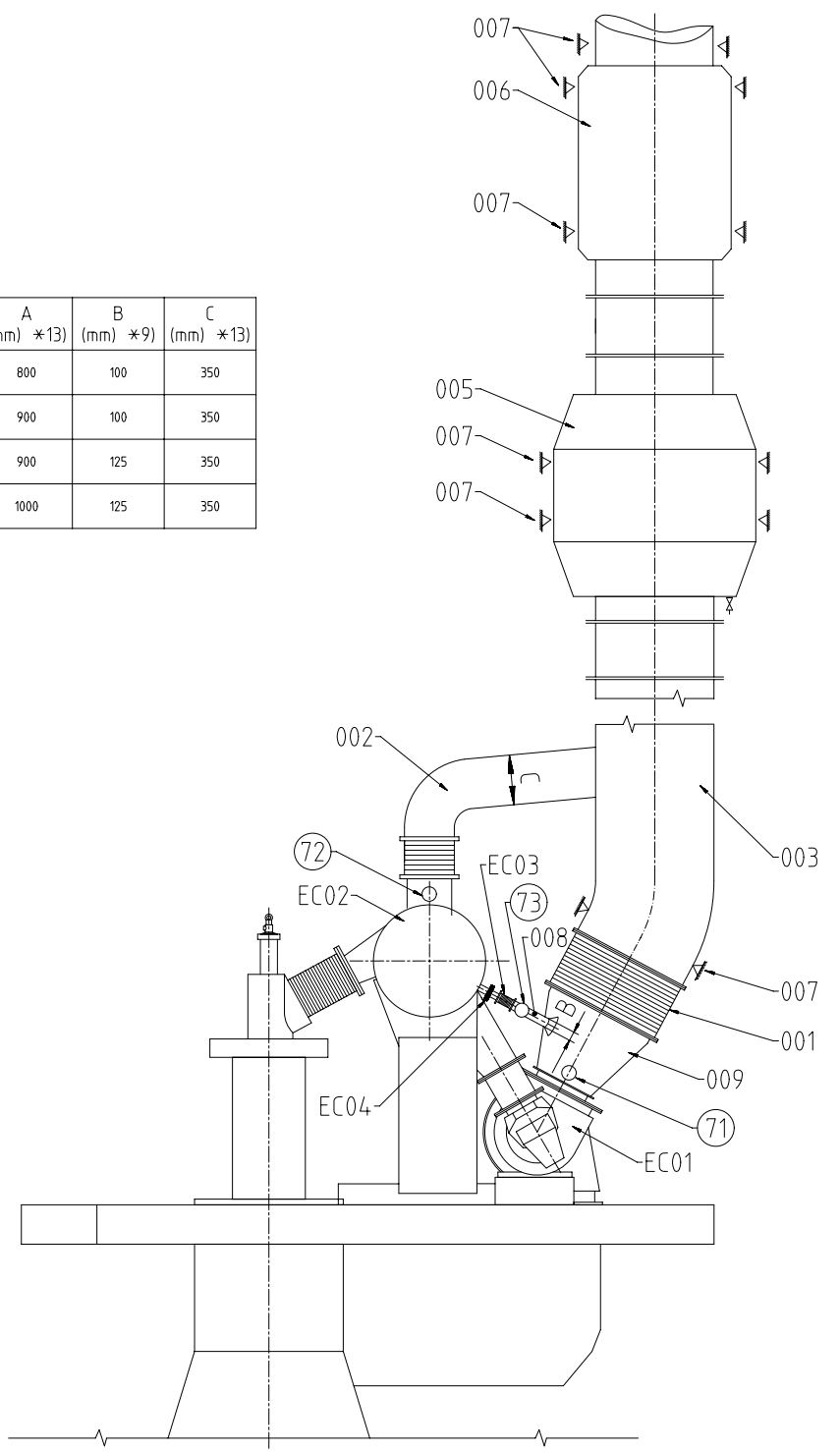

- | Pos. | SYSTEM COMPONENTS *1) |
|------|-------------------------------------|
| 001 | Compensator *4) |
| 002 | Exhaust gas by-pass line *8) |
| 003 | Exhaust gas pipe *12) |
| 005 | Boiler *11) |
| 006 | Silencer (with spark arrester) *10) |
| 007 | Support *6) |
| 008 | Waste gate pipe |
| 009 | Transition piece *7) |
-
- | Pos. | ENGINE CONNECTIONS *2) |
|------|--|
| ⑦1 | OUTLET - Exhaust gas turbocharger |
| ⑦2 | OUTLET - Exhaust gas by-pass |
| ⑦3 | OUTLET - Exhaust gas manifold waste gate |
-
- | Pos. | ENGINE COMPONENTS *3) |
|------|--------------------------------|
| EC01 | Turbocharger |
| EC02 | Exhaust gas manifold |
| EC03 | Waste gate compensator *4) *9) |
| EC04 | Waste gate valve |
- Remarks: Ⓒ
- Drain plugs and drain cocks to be installed where necessary.
 - *1) Refer to the "Pipe Connection Plan" for the execution and location of the engine pipe connections.
 - *2) To be delivered by external supplier and to be installed by the shipyard.
 - *3) To be delivered by the engine builder, i.e. already equipped on engine side
 - *4) Dimension of expansion piece (compensator) must be defined by the shipyard taking into account the thermal growth of exhaust manifold and exhaust pipe. Vibrations of the pipe after the compensator must be lower than 45 mm/s RMS (root mean square).
 - *6) Installed as fixed or sliding type in accordance with the requirements. Final amount and position have to be defined by the shipyard under consideration of system layout and requirements based on installation specific calculation.
 - *7) Area ratio between outlet/inlet diameter = 1.1..1.6
Taper angle $\leq 40^\circ$
 - *8) Optional, needs just to be installed if requested by owner and class to ensure engine operation even after a turbocharger failure.
 - *9) Pipe dimension on engine side (before compensator) is one nominal pipe size smaller.
 - *10) Optional, installed as required to meet noise requirements.
 - *11) Optional.
 - *12) The radius of pipe bends should be not smaller than 1.5 x DN.
 - *13) The provided dimensions refer to an R1 rated engine and serve just as proposal. To make the project specific layout, data as provided by GTD and by the turbocharger supplier must be taken into account.

Free space for use	Q-Code	Max. Drw.
	XXXXXX	
	Standard	
	ISO; JIS	
Mod. A	EAD09374	11.05.2018
Mod. B	EAD09305	11.01.2019
Mod. C	EAD09326	05.04.2019
Mod. D		
Number	Drawn date	Number
Product		Net Weight 0,001
5-BX4.0-B		
Exhaust System		
with one turbocharger		
Units	mm kg	NX
Basic Material		
Scale	-	
Size	A1	
Page	2/2	
Material ID	PAAD283786	
Made	23.01.2018	dk1021 DH.Kim
Chd	14.02.2018	waa008 Wang
Design Group		
Drawing ID	DAAD096529	
Appd	28.02.2018	mhu019 Hug
9726		

MIDS WinGD X40-B - EXHAUST SYSTEM (DG9726)

TRACK CHANGES

DATE	SUBJECT	DESCRIPTION
2018-04-25	DRAWING SET	First web upload
2018-05-22	DAAD096529	System drg - new revision
2019-01-15	DAAD096529	System drg - new revision
2019-09-16	DAAD096529	System drg - new revision

DISCLAIMER

© Copyright by Winterthur Gas & Diesel Ltd.

All rights reserved. No part of this document may be reproduced or copied in any form or by any means (electronic, mechanical, graphic, photocopying, recording, taping or other information retrieval systems) without the prior written permission of the copyright owner.

THIS PUBLICATION IS DESIGNED TO PROVIDE AN ACCURATE AND AUTHORITATIVE INFORMATION WITH REGARD TO THE SUBJECT-MATTER COVERED AS WAS AVAILABLE AT THE TIME OF PRINTING. HOWEVER, THE PUBLICATION DEALS WITH COMPLICATED TECHNICAL MATTERS SUITED ONLY FOR SPECIALISTS IN THE AREA, AND THE DESIGN OF THE SUBJECT-PRODUCTS IS SUBJECT TO REGULAR IMPROVEMENTS, MODIFICATIONS AND CHANGES. CONSEQUENTLY, THE PUBLISHER AND COPYRIGHT OWNER OF THIS PUBLICATION CAN NOT ACCEPT ANY RESPONSIBILITY OR LIABILITY FOR ANY EVENTUAL ERRORS OR OMISSIONS IN THIS BOOKLET OR FOR DISCREPANCIES ARISING FROM THE FEATURES OF ANY ACTUAL ITEM IN THE RESPECTIVE PRODUCT BEING DIFFERENT FROM THOSE SHOWN IN THIS PUBLICATION. THE PUBLISHER AND COPYRIGHT OWNER SHALL UNDER NO CIRCUMSTANCES BE HELD LIABLE FOR ANY FINANCIAL CONSEQUENTIAL DAMAGES OR OTHER LOSS, OR ANY OTHER DAMAGE OR INJURY, SUFFERED BY ANY PARTY MAKING USE OF THIS PUBLICATION OR THE INFORMATION CONTAINED HEREIN.