

Lubricants

all engines

Issue 006 2020-08

Winterthur Gas & Diesel Ltd.
Winterthur Gas & Diesel AG
Winterthur Gas & Diesel S.A.

Schützenstrasse 3
P.O. Box 414, 8401
Winterthur, Switzerland

Tel. +41 (0)52 264 8844
Fax +41 (0)52 264 8866
www.wingd.com

WIN GD
Winterthur Gas & Diesel

© 2020 Winterthur Gas & Diesel Ltd. – All rights reserved

No part of this publication may be reproduced or copied in any form or by any means (electronic, mechanical, graphic, photocopying, recording, taping or other information retrieval systems) without the prior written permission of the copyright holder. Winterthur Gas & Diesel Ltd. makes no representation, warranty (express or implied) in this publication and assumes no responsibility for the correctness, errors or omissions of information contained herein. Information in this publication is subject to change without notice.

NO LIABILITY, WHETHER DIRECT, INDIRECT, SPECIAL, INCIDENTAL OR CONSEQUENTIAL, IS ASSUMED WITH RESPECT TO THE INFORMATION CONTAINED HEREIN. THIS PUBLICATION IS INTENDED FOR INFORMATION PURPOSES ONLY.

www.wingd.com

1 Lubricants - change record

Tab 1 Change record

Data module code, issue Chapter number - technical name Reason for change	Status
Revised issue 006, 2020-08	
WINGD-AA00-HA1-50-0000-00AAA-101A-A , issue 08 3 - Cylinder oils Updated text in section 3.1	revised
Revised issue 005, 2020-06	
WINGD-AA00-HA1-50-0000-00AAA-101A-A , issue 07 3 - Cylinder oils Updated Fig 1	revised
WINGD-AA00-HA1-50-0000-00AAA-101A-A , issue 07 4 - List of cylinder oils List removed and linked to the WinGD website	revised
WINGD-AA00-HA1-50-0000-00AAA-101B-A , issue 05 9 - List of system oils Some suppliers added	revised
Revised issue 004, 2019-12	
WINGD-AA00-HA1-50-0000-00AAA-101A-A , issue 06 4 - List of cylinder oils Different changes	revised
WINGD-AA00-HA1-50-0000-00AAA-101B-A , issue 04 4 - List of system oils Added supplier (Cosmo) and changed supplier name (IndianOil)	revised
Different data modules N/A Different text changes	revised
Revised issue 003, 2019-03	
WINGD-AA00-HA1-50-0000-00AAA-003B-A , issue 01 1 - Lubricants - change record New chapter 1	new
WINGD-AA00-HA1-50-0000-00AAA-030G-A , issue 06 3 - Cylinder oils Revised Fig 1 - Selection of cylinder oil BN related to the fuel sulphur content	revised

Data module code, issue Chapter number - technical name Reason for change	Status
WINGD-AA00-HA1-50-0000-00AAA-101A-A , issue 04 4 - List of cylinder oils Added supplier (ENOC) and added oils (ExxonMobil and Gulf Oil Marine)	revised

2 General for lubricants

This document is related to cylinder oils, system oils and other oils for large marine two-stroke engines.

The document includes data for the items that follow:

- Requirements for oils
- Lists of validated oils, or data on where to get up to date lists of validated oils
- Procedures for oil selection
- Procedures for oil analysis interpretation
- Procedure for running-in new components.

NOTE: Some chapters of this document are also part of the Operation Manuals of WinGD engines.

3 Cylinder oils

Cylinder oil is used for the functions that follow:

- Neutralize the sulphuric acids that occur during combustion to prevent corrosion on piston rings and cylinder liners
- Make sure that an oil film between the cylinder liner and the piston rings is built and thus the friction is decreased
- Keep the piston, the piston rings and the cylinder liners free from deposits.

The correct feed rate range for cylinder oil is between 0.6 g/kWh and 1.2 g/kWh.

3.1 Requirements for cylinder oil

The cylinder oil must have the basic properties that follow:

- The cylinder oil must contain suitable alkalinity and have an SAE 50 viscosity (minimum kinematic viscosity of 18.5 cSt at 100°C)
- The selected Base Number (BN) of the cylinder oil must be related to the items that follow:
 - Engine operation condition
 - Cylinder lubricating feed rate
 - Sulphur content of the fuel.

NOTE: The Base Number (BN), measured in mg KOH/g (test method ASTM D 2896), is a measure of the alkalinity of the oil. The BN of the cylinder oil is not an index for detergency or for other properties of the cylinder oil.

Find a list of applicable and validated cylinder oils in section [4 List of cylinder oils](#).

3.2 Recommended procedures

WinGD recommends the procedures that follow to get good performance of the piston running components:

- 1 Select the cylinder oil, refer to [Para 3.2.1](#).
- 2 Do an engine screening procedure, refer to [Para 3.2.2](#).
- 3 Do a piston underside drain oil sampling, refer to [Para 3.2.3](#).
- 4 Do an interpretation of the oil analysis as follows:
 - For a cylinder oil with BN 25 or lower refer to [Para 3.2.4](#).
 - For a cylinder oil with BN 40 or higher refer to [Para 3.2.5](#).
- 5 Do an optimization of the feed rate, refer to [Para 3.2.6](#).
- 6 Regularly do step 3 to step 5 again.

3.2.1 Selection of the cylinder oil

For the initial selection of an applicable cylinder oil use the data given in [Figure 1](#). The higher the sulphur content of the fuel, the higher the BN of the cylinder oil must be - within the given limits.

After you have selected the applicable BN range, you can select a specific cylinder oil from the related list, refer to section [4 List of cylinder oils](#).

Fig 1 Selection of cylinder oil BN related to the fuel sulphur content

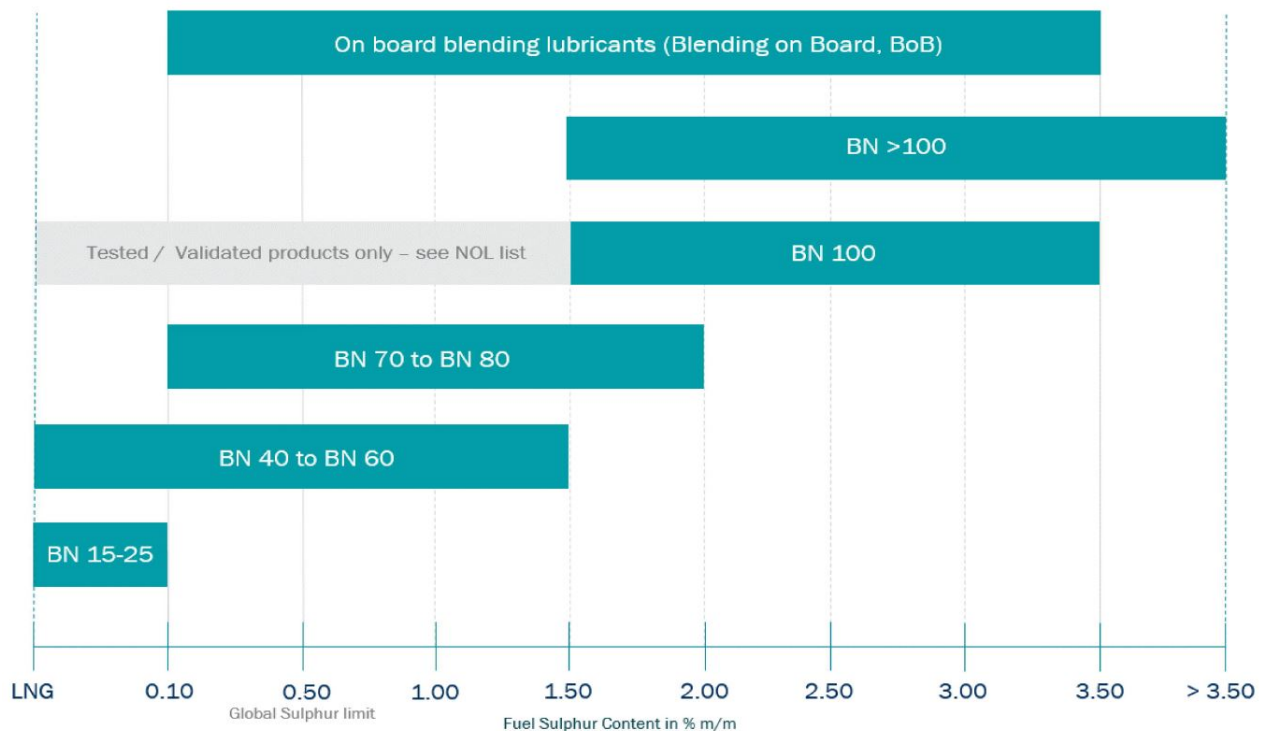

3.2.2 Engine screening procedure

After the running-in of the engine, get initial data for the engine. WinGD recommends to do an engine screening procedure as follows:

- 1 Set the base feed rate of the selected cylinder oil to 0.9 g/kWh.
- 2 Operate the engine at different loads, for example 10%, 20%, 30% etc related to the sailing conditions.
- 3 For each load do a piston underside drain oil sampling, refer to [Para 3.2.3](#).
- 4 For each load do an interpretation of the oil analysis, refer to [Para 3.2.4](#) or [Para 3.2.5](#).

3.2.3 Piston underside drain oil sampling

Do a piston underside drain oil sampling and an oil analysis of each cylinder, refer to the procedure in section [5 Do an analysis of the cylinder oil](#).

3.2.4 Interpretation of the oil analysis for a cylinder oil with BN 25 or lower

For a cylinder oil with BN 25 or lower, refer to [Figure 2](#) for the interpretation of the drain oil analysis results.

Fig 2 Interpretation of the oil analysis for cylinder oils with BN 25 or lower

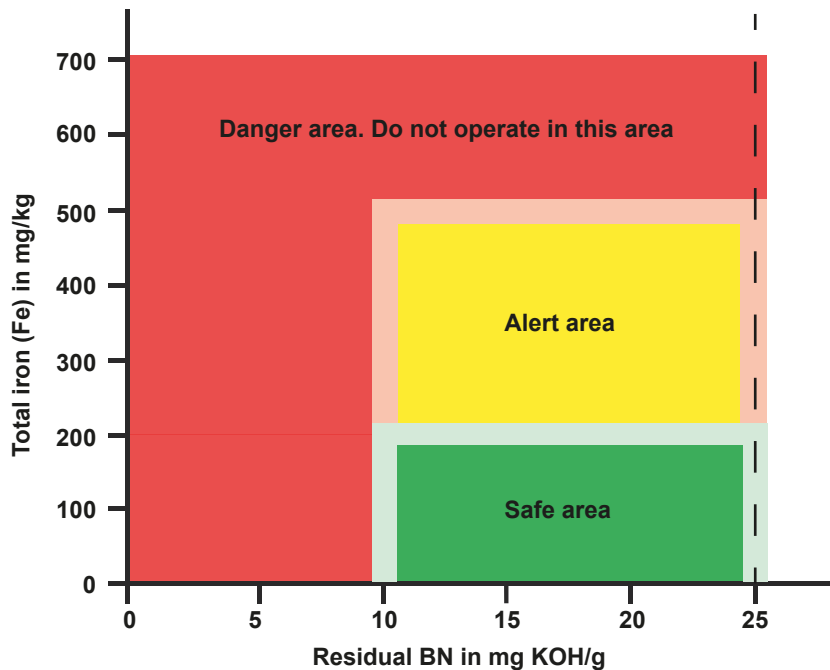

00596

NOTE: There are smooth transitions between the different areas shown in [Figure 2](#).

Use the data that follows for an interpretation of the oil analysis:

- **Safe area**

If the residual BN is BN 10 or higher and the iron (Fe) content is less than 200 mg/kg, the operation is thought to be safe.

- **Alert area**

If the residual BN is BN 10 or higher and the iron (Fe) content is between 200 mg/kg and 500 mg/kg, damage of the piston running system can occur.

- **Danger area**

If the residual BN is less than BN 10 and/or the iron (Fe) content is more than 500 mg/kg, excessive corrosion can occur. Thus the piston rings and cylinder liners can become quickly worn. Scuffing can also occur.

3.2.5 Interpretation of the oil analysis for a cylinder oil with BN 40 or higher

For a cylinder oil with BN 40 or higher, refer to [Figure 3](#) for the interpretation of the drain oil analysis results.

Fig 3 Interpretation of the oil analysis for cylinder oils with BN 40 or higher

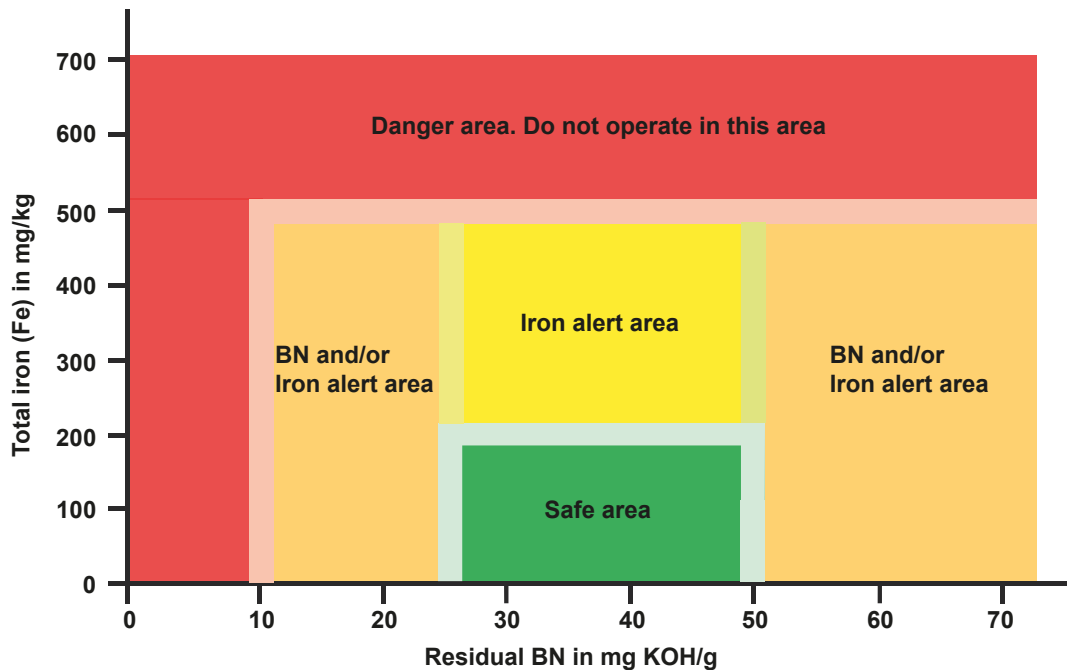

00115

NOTE: There are smooth transitions between the different areas shown in [Figure 3](#).

Use the data that follows for an interpretation of the oil analysis:

- **Safe area**

If the residual BN is between BN 25 and BN 50, and the iron (Fe) content is less than 200 mg/kg, the operation is thought to be safe.

- **Alert area**

The lower alert range for piston underside residual BN is between BN 10 and BN 25. In this area there might be a risk of corrosion. This is because the base additives could be not sufficient to neutralize the sulphuric acid from the fuel combustion.

The upper alert limit for piston underside residual BN is above BN 50. Higher residual alkalinity can cause damage to the piston running system because of excessive deposits on the piston. If there are excessive deposits on the piston, the lubricant film can break down and thus cause wear of the piston running system.

The alert range for iron (Fe) content in the drain oil is between 200 mg/kg and 500 mg/kg.

- **Danger area**

The danger limit for piston underside residual BN is lower than BN 10. In this area it is possible that excessive corrosion can occur. Thus the piston rings and cylinder liners can become quickly worn. Scuffing can also occur. Piston rings can quickly become defective.

The danger limit for iron (Fe) content in the drain oil is more than 500 mg/kg.

Do not operate the engine in these danger areas.

3.2.6 Optimization of the feed rate

After the interpretation of the oil analysis do an optimization of the feed rate as follows:

- 1 If the analysis shows operation in the safe area, do one of the two instructions:
 - a Continue the operation with the current feed rate.
 - b Decrease the feed rate in small steps, for example in steps of 0.05 g/kWh.
- 2 If the analysis shows operation in one of the alert areas, do one of the two instructions:
 - a Increase or decrease the feed rate to get the operation in the safe area. If necessary, change the BN of the cylinder oil.
 - b Keep the feed rate and do regular checks of the piston ring and the cylinder liner conditions through scavenge port inspections.
- 3 If the analysis shows operation in the danger area, do as soon as possible:
 - a Increase or decrease the feed rate or change the BN of the cylinder oil to get the operation in the safe area.

NOTE: WinGD has made a tool (piston underside drain oil analysis) for easier interpretation of the oil analysis. If necessary, the tool gives you recommendations and procedures to make the cylinder oil system better. Only use the tool, if you use a cylinder oil with BN 40 or higher.

If you want to use the tool, speak to or send a message to WinGD.

WinGD recommends to collect the data from the oil analyses. When you later use a fuel with the same sulphur content ($\pm 0.125\%$ m/m) and a cylinder oil with the same BN, you can set the feed rate related to the collected data with the same conditions. You also can use these data to get continuously better performance of the cylinder oil.

3.3 Effective feed rate

The cylinder lubricating feed rate that is set in the engine control system is the specific feed rate at 100% CMCR. At part load operation, a correction factor is applied in order to make sure a sufficient quantity of cylinder oil is supplied. Thus the effective feed rate at part load is usually higher than the set feed rate.

4 List of cylinder oils

Always use a cylinder oil that obeys the WinGD general lubricating oil specifications and recommendations given in the Operation Manual.

The oil supplier assumes all responsibility for the performance of the cylinder oils used to the exclusion of any liability of WinGD and of companies that are part of the WinGD group. The oil supplier along with other possible manufacturers and distributors of the related products shall indemnify, compensate and hold harmless WinGD and companies that are part of the WinGD group from and against any claims, damages and losses caused by the use of their cylinder oils.

NOTE: The Base Number (BN), measured in mg KOH/g (test method ASTM D 2896), is a measure of the alkalinity of the oil.

Tab 2 List of validated cylinder oils and blending on board additives

The up to date List of validated cylinder oils and blending on board additives is freely available on the WinGD website, refer to:

www.wingd.com/en/technology-innovation/engine-technology/engine-design/tribology-fuels-lubricants/

5 Do an analysis of the cylinder oil

Periodicity

Description	
Weeks	1
Unscheduled	After a fuel change
Unscheduled	After a cylinder oil change
Unscheduled	After a feed rate change
Duration for performing preliminary requirements	2.0 man-hours
Duration for performing the procedure	6.0 man-hours
Duration for performing the requirements after job completion	0.0 man-hours

Personnel

Description	Specialization	QTY
Engine crew	Basic	1

Support equipment

Description	Part No.	CSN	QTY
None			

Supplies

Description	QTY
Sample bottles	A/R

Spare Parts

Description	Part No.	CSN	QTY
None			

SAFETY PRECAUTIONS

CAUTION

Injury Hazard: The cylinder oil is hot. Put on gloves and safety goggles to prevent injury. Do the work carefully.

PRELIMINARY OPERATIONS

- The engine must be in stable operation for a minimum of 12 hours.
- The duration of the procedure is related to the number of cylinders.

PROCEDURE

Fig 4 Location of ball valves - dirty oil samples

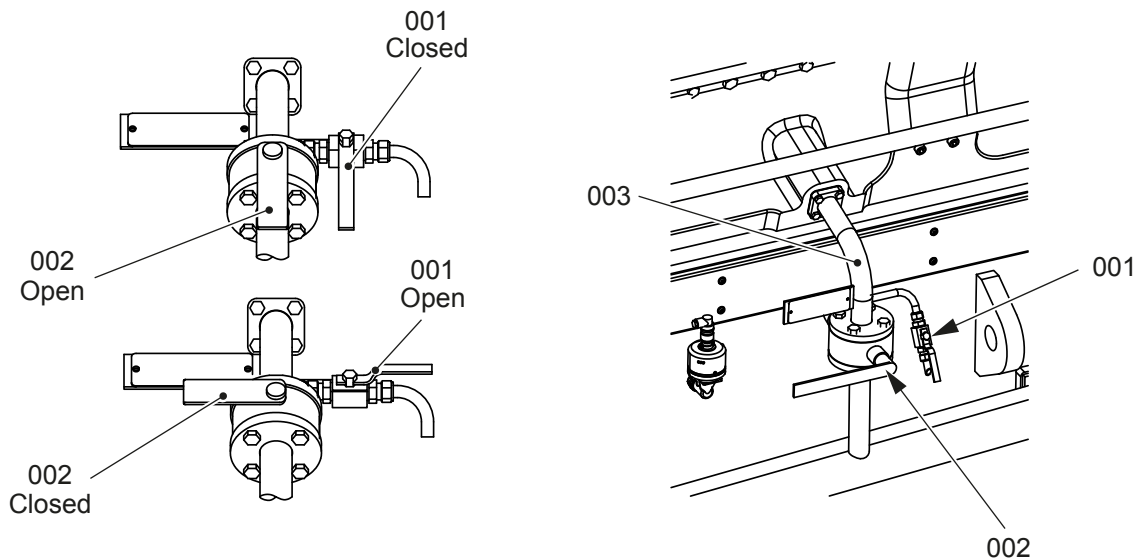

00010

- 1 Do this procedure at a minimum of one time each week, and do it also in the conditions that follow:
 - After a fuel change
 - After a cylinder oil change
 - After a feed rate change.
- 2 Flush the sample pipe of the related cylinder.
 - 2.1 Close the ball valve (002, [Figure 4](#)) for approximately 30 minutes to 60 minutes.

NOTE: Some parts can look different.
 - 2.2 Put an applicable container under the oil sample valve (001).
 - 2.3 Slowly open the oil sample valve (001) to flush out oil and possible dirt.
 - 2.4 Close the oil sample valve (001).
 - 2.5 Open the ball valve (002) to drain the remaining oil from the dirty oil pipe (003).
 - 2.6 Close the ball valve (002).
- 3 Get a sample of the drain oil.
 - 3.1 Make sure that the label on the sample bottle refers to the related cylinder.
 - 3.2 Wait approximately 10 to 60 minutes.
 - 3.3 Put the sample bottle under the oil sample valve (001).
 - 3.4 Slowly open the oil sample valve (001) to fill the sample bottle.
 - 3.5 Close the oil sample valve (001).
 - 3.6 Open the ball valve (002) to drain the oil in the dirty oil pipe (003).
- 4 Do [Step 2](#) and [Step 3](#) again for each cylinder.

- 5** Write the applicable data on the oil analysis form (for example operation conditions, fuel parameters, cylinder lubricating feed rate).
- 6** Do an oil analysis of the samples on-board. The oil analysis must include the data that follows:
 - Residual BN
 - Iron (Fe) content (if possible).
- 7** If necessary, do the applicable recommended procedures, refer to section [3 Cylinder oils](#) or to the document “Lubricants” on the WinGD website (<https://www.wingd.com/>).
- 8** Send the oil samples to a laboratory for an oil analysis.
 - 8.1** Make sure that the sample bottles are tightly closed.
 - 8.2** Put the sample bottles in an applicable package.
- 9** Compare the oil analysis from the laboratory with the oil analysis from on-board.
- 10** If the oil analyses are different, do the applicable recommended procedures related to the oil analysis from the laboratory, refer to section [3 Cylinder oils](#) or to the document “Lubricants” on the WinGD website (<https://www.wingd.com/>).

CLOSE UP

- None

6 Running-in of new components - general

After an overhaul or an installation of new components of the piston running system, WinGD recommends a running-in procedure. This makes sure a correct film of cylinder oil on the piston running system is built. The procedure includes a temporary higher feed rate, refer to [Figure 5](#).

WinGD recommends an inspection of the cylinder liners and of the piston rings after 24 operation hours and after 72 operation hours (001, [Figure 5](#)). For this running-in procedure it is not necessary to have a special loading up apart from vessel specific loading up protocols.

Fig 5 Feed rate adjustments - running-in

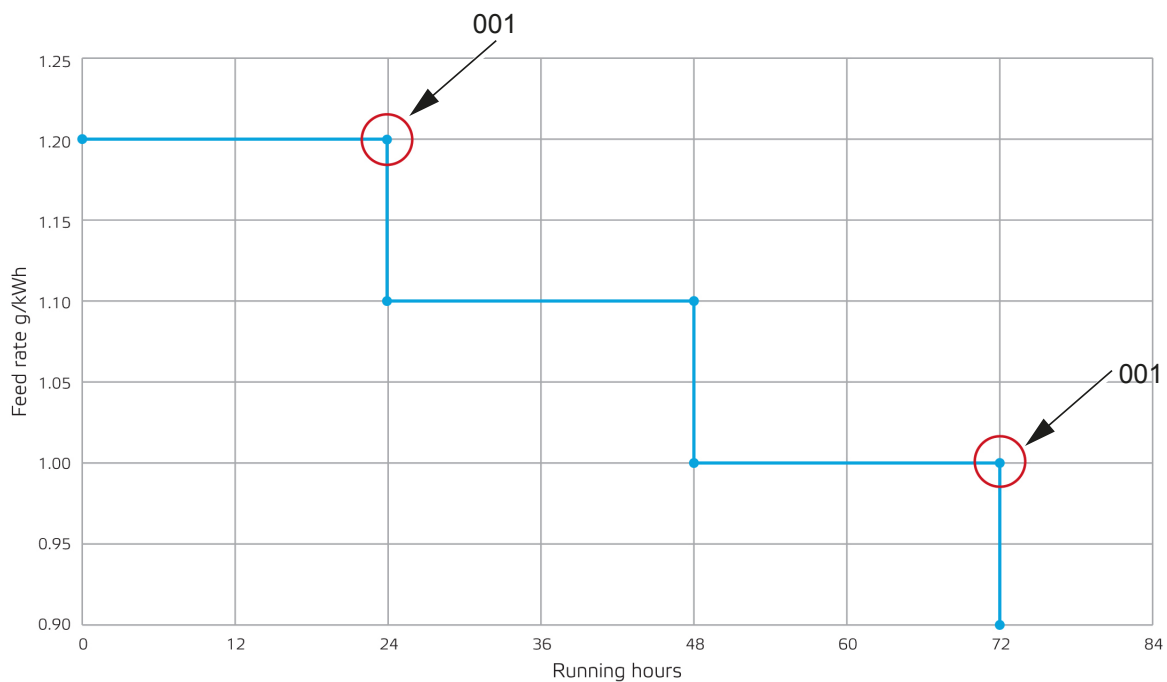

7 Running-in of new components

Periodicity

Description	
Unscheduled	
Duration for performing preliminary requirements	0.0 man-hours
Duration for performing the procedure	72.0 man-hours
Duration for performing the requirements after job completion	0.0 man-hours

Personnel

Description	Specialization	QTY
Engine crew	Intermediate	1

Support equipment

Description	Part No.	CSN	QTY
None			

Supplies

Description	QTY
None	

Spare Parts

Description	Part No.	CSN	QTY
None			

SAFETY PRECAUTIONS

- None

PRELIMINARY OPERATIONS

- This procedure is only applicable after an overhaul or an installation of new components of the piston running system.

PROCEDURE

- 1 Set the cylinder lubricating feed rate for the applicable cylinders in the control system to 1.2 g/kWh.
- 2 Operate the engine for 24 hours.
- 3 Inspect the components for damage.
- 4 If damage occurs, find the cause and repair the fault.
- 5 If it is necessary to replace parts of the piston running system, do [Step 2](#) and [Step 3](#) again.
- 6 Set the feed rate to 1.1 g/kWh.
- 7 Operate the engine for 24 hours.
- 8 Set the feed rate to 1.0 g/kWh.
- 9 Operate the engine for 24 hours.
- 10 Inspect the components for damage.
- 11 If damage occurs, find the cause and repair the fault.
- 12 If it is necessary to replace parts of the piston running system, start with [Step 1](#) again.
- 13 Set the feed rate to 0.9 g/kWh.

CLOSE UP

- After 72 hours set the feed rate to the usual settings. Refer to the document "Lubricants" on the WinGD website (<https://www.wingd.com/>) or to section [3 Cylinder oils](#)

8 System oils

System oil has the functions that follow:

- System oil lubricates the bearings, the running parts of the engine and the crosshead assemblies.
- System oil decreases the temperature of the pistons and the vibration dampers.
- System oil is used as hydraulic fluid in the servo oil system.

8.1 Requirements for system oil

The system oil must have the basic properties that follow:

- An additive-type crankcase oil of SAE 30 viscosity
- Minimum Base Number (BN) of 5 mg KOH/g
- Minimum failure load stage of 11 ± 1 related to the FZG gear oil test method A/8.3/90 (ISO 14635-1)
- Detergency properties
- Thermal stability
- Anti-corrosion properties
- Anti-foam properties
- Demulsifying performance.

Find a list of applicable and validated system oils in section [9 List of system oils](#).

8.2 Recommended procedure for system oil maintenance

WinGD recommends the installation of a self-cleaning centrifugal separator in the plant oil system to keep the system oil in good condition for a long period.

- There is always a risk that water, specially sea water, can enter the system oil and cause corrosion on engine parts. Water contamination can also cause bacterial contamination of the system oil, which causes a decrease in lubrication performance and heavy corrosion of the engine parts. Thus solid contaminants (dirt) and water must be removed from the system oil as completely and as frequently as possible.
- The self-cleaning centrifugal separator is used as a purifier in bypass mode. The oil flows from the oil tank through the centrifugal separator. Set the oil flow through the centrifugal separator related to the manufacturer of the centrifugal separator. WinGD recommends an oil temperature for this treatment of 95°C unless the manufacturer of the centrifugal separator recommends differently.

8.3 Alert and condemnation limits for system oil

Table 3 - Alert and condemnation limits for system oil shows the WinGD recommendations for alert and condemnation limits for system oil.

Tab 3 Alert and condemnation limits for system oil

Parameter	Alert limit	Condemnation limit	Unit	Test method
Viscosity at 40°C	Maximum 140	Maximum 150	mm ² /s [cSt]	ASTM D 445
Flash point	Minimum 200	Minimum 180	°C	ASTM D 92/93
Total insoluble materials	Maximum 0.7	Maximum 1.0	% m/m ¹	ASTM D 893b
Base Number (BN)	Maximum 12	Maximum 15	mg KOH/g	ASTM D 2896
Water content	Maximum 0.20	Maximum 0.30	% m/m	ASTM D 95 or ASTM D 1744
Strong Acid Number (SAN)	0.0	0.0	mg KOH/g	ASTM D 664
Calcium	-	Maximum 6000	mg/kg [ppm]	ICP
Zinc	-	Minimum 100	mg/kg [ppm]	ICP
Phosphorus	-	Minimum 100	mg/kg [ppm]	ICP
FZG gear oil test ²	Minimum failure load stage (FLS) 9	Minimum failure load stage (FLS) 8	-	A/8.3/90 (ISO 14635-1)

¹ % m/m means by mass, for example a water content of 0.20% m/m means that the water content is 0.20% of the mass of the total solution.

² WinGD recommends to do an FZG gear oil test one time each year.

NOTE: Use these limits as a guide. It is not possible to make an estimate of the condition of the system oil by only one parameter. Thus measure also other oil parameters to find the causes of problems.

8.4 Particle count and size classes

The requirements for particle size analysis applies only for hydraulic systems. These systems operate the exhaust valves, the cylinder oil system and the fuel injection system (if applicable). Abrasive particles in the oil can cause wear on different parts of the engine. Some types of WinGD engines have a filter for servo oil.

8.4.1 Specifications

There are two different specifications for particle classes:

- ISO 4406
- NAS 1638 and SAE AS 4059

The (newer) ISO 4406 particle count and size classes for oils are given in [Table 4 - Particle count and size classes ISO 4406](#).

Tab 4 Particle count and size classes ISO 4406

WinGD recommendations	Number of particles per 100 ml		
	More than	Up to and includes	Class
	250 000 000	-	Less than 28
	130 000 000	250 000 000	28
	64 000 000	130 000 000	27
	32 000 000	64 000 000	26
	16 000 000	32 000 000	25
	8 000 000	16 000 000	24
	4 000 000	8 000 000	23
	2 000 000	4 000 000	22
	1 000 000	2 000 000	21
> 6 µm max.	500 000	1 000 000	20
	250 000	500 000	19
	130 000	250 000	18
> 14 µm max.	64 000	130 000	17
	32 000	64 000	16
	16 000	32 000	15
	8 000	16 000	14
	4 000	8 000	13
	2 000	4 000	12
	1 000	2 000	11
	500	1 000	10
	250	500	9
	130	250	8
	64	130	7
	32	64	6
	16	32	5
	8	16	4
	4	8	3
	2	4	2
	1	2	1
	0	1	0

The ISO 4406 particle count system has specified three size classes related to a 100 ml oil sample as follows:

- R_4 = number of particles equal to or larger than 4 μm
- R_6 = number of particles equal to or larger than 6 μm
- R_{14} = number of particles equal to or larger than 14 μm .

The (older) NAS 1638 and SAE AS 4059 cleanliness classes for oils are given in [Table 5 - Cleanliness classes NAS 1638 and SAE AS 4059](#).

Tab 5 Cleanliness classes NAS 1638 and SAE AS 4059

Cleanliness class	Number of particles per 100 ml for particle size ranges (μm)				
	5 to 15	15 to 25	25 to 50	50 to 100	100 to 150
(14)	4 096 000	729 600	129 600	23 040	4 096
(13)	2 048 000	364 800	64 800	11 520	2 048
12	1 024 000	182 400	32 400	5 760	1 024
11	512 000	91 200	16 200	2 880	512
10	256 000	45 600	8 100	1 440	256
9	128 000	22 800	4 050	720	128
8	64 000	11 400	2 025	360	64
7	32 000	5 700	1 012	180	32
6	16 000	2 850	506	90	16
5	8 000	1 425	253	45	8
4	4 000	712	126	22	4
3	2 000	356	63	11	2
2	1 000	178	32	6	1
1	500	89	16	3	1
0	250	44	8	2	0
00	125	22	4	1	0

8.4.2 Recommended limits

For particles up to 21 µm, WinGD recommends the specification for a 100 ml oil sample in the system oil as follows:

- ISO 4406 --/20/17 maximum

The result of this specification is as follows:

- It is not necessary to count particles of a size of smaller than 6 µm (R_4 count).
- A maximum of 1 000 000 particles (class 20) of a size equal to or larger than 6 µm (R_6 count) is permitted.
- A maximum of 130 000 particles (class 17) of a size equal to or larger than 14 µm (R_{14} count) is permitted.

For particles larger than 21 µm, you must obey the NAS and SAE AS specification as in [Table 6 - Recommended NAS limits for an engine with servo oil filter](#) and in [Table 7 - Recommended NAS limits for an engine without servo oil filter](#).

Tab 6 Recommended NAS limits for an engine with servo oil filter

	Particle size ranges (µm)				
	5 to 15	15 to 25	25 to 50	50 to 100	100 to 150
System oil					
- Cleanliness class	12	11	10	8	5
- Particles per 100 ml	1 024 000	91 200	8 100	360	8
Servo oil					
- Cleanliness class	12	11	8	5	0
- Particles per 100 ml	1 024 000	91 200	2 025	45	0

Tab 7 Recommended NAS limits for an engine without servo oil filter

	Particle size ranges (µm)				
	5 to 15	15 to 25	25 to 50	50 to 100	100 to 150
System oil					
- Cleanliness class	12	11	9	7	5
- Particles per 100 ml	1 024 000	91 200	4 050	180	8

- NOTE:**
- Particle counting has poor repeatability and reproducibility.
 - The method does not determine the nature, hardness or shape of the particles.
 - Use the used oil analysis and particle count data to form a better picture.

8.5 Recommended procedure for samples

WinGD recommends to get a sample of the system oil each 3000 operating hours for regular oil analysis and each 6000 operating hours for additional FZG and particle count (ISO 4406 and NAS 1638) analyses. Get the oil samples at the correct oil sample points:

- For an engine with servo oil filter, do as follows:
 - Get a sample from the sample point at the engine inlet.
 - If the analysis shows unusual values, get a sample from the sample point after the servo oil filter.
- For an engine without servo oil filter, get the sample from the sample point at the engine inlet.

For the related procedure, refer to section [10 Do an analysis of the system oil](#).

Send the samples immediately to a laboratory to do the correct analyses.

With these regular checks you find deterioration in time. Thus you can do the correct procedures.

8.6 Recommended procedures related to the results

If one or more of the alert values in [Table 3 - Alert and condemnation limits for system oil](#) are shown, do the applicable procedures to correct the problem. WinGD recommends that you speak to the system oil supplier in such a condition. Applicable procedures are as follows:

- Increase the purification in the separator (decrease the flow rate and/or adjust the temperature).
- Treat the oil in a renovating or settling tank.
- Replace a part of the system oil.

If an alert value is shown, stop the engine and do the correct procedures.

If a condemnation value is shown, immediately replace a part of the system oil until the values are satisfactory. If this is not possible, stop the engine until it is possible to change a part of the system oil. This gives satisfactory system oil values again.

8.6.1 Base Number (BN) increases suddenly

If the Base Number (BN) of the system oil increases suddenly, do a check of all piston rod gland boxes and of the piston rod conditions. If necessary, replace the sealing rings of the related gland box or repair the gland box.

NOTE: If the BN increases by a small quantity, this is usually an indication that the system oil consumption is low. A usual consumption and replenishment of system oil is necessary to keep the system oil in good condition.

8.6.2 Flash point decreases

If the flash point of the system oil decreases below the values given in [Table 3 - Alert and condemnation limits for system oil](#), do a replenishment of the system oil. This prevents an increase of the BN of the system oil.

8.6.3 Particle number increases

If the particle number of the particle count increases above the limits given in [Para 8.4.2](#), do the procedures that follow in the given sequence:

- For an engine with a servo oil filter:
 - Do a check of the servo oil filter. If necessary, replace the filter element or repair the filter.
- For each engine:
 - Do a check of the centrifugal separator. If necessary, adjust the flow rate or the temperature to increase the performance of the centrifugal separator. Refer to the manufacturers recommendations.
 - Do a check of all piston rod gland boxes. If necessary, replace the sealing rings of the related gland box or repair the gland box.
 - Do an element analysis of the particles. This gives data about worn components in the engine. Repair the related components.
 - Do a replenishment of the system oil. This can include a change of some of the oil or of all of the oil in the oil system.

This prevents damage from abrasive particles of the related engine parts.

8.7 Recommended procedure for gear wheels

If a new gear wheel has been installed, or if a gear wheel has been polished, the FZG load stage of the system oil must be at a satisfactory value. This prevents scuffing of the gear wheels during the running-in of the gear wheels.

If system oil is in use for more than one year, do the FZG gear oil test (test method A/8.3/90, ISO 14635-1). If the related alert or condemnation value is shown (refer to [Table 3 - Alert and condemnation limits for system oil](#)), do a replenishment of the system oil before running-in.

9 List of system oils

Always use system oils related to the WinGD general system oil specifications and recommendations given in the Operation Manual.

The oil supplier assumes all responsibility for the performance of the system oils used to the exclusion of any liability of WinGD and of companies that are part of the WinGD group. The oil supplier along with other possible manufacturers and distributors of the related products shall indemnify, compensate and hold harmless WinGD and companies that are part of the WinGD group from and against any claims, damages and losses caused by the used system oils.

NOTE: For system oils that are not listed in the table and for new system oils, speak to or send a message to WinGD.

Tab 8 List of validated system oils (SAE 30) (June 2020)

Supplier	Brand	Base number (BN)
Aegean	Alfasys 305	5
AVIN	Panoil M 530	5
Castrol	CDX 30	5
Cepsa	Ciconia 30	5
Chevron	Veritas 800 Marine 30	5
Cosmo	Marine 3005	5
CPC	Marilube Oil AC-30 Plus	5
	Marilube Oil AC-30 SP	5
Cyclon Hellas	Armor Medium SAE 30	5
ENI	Cladium 50	5
ExxonMobil	Mobilgard 300 C	9
FL Selenia	MESYS 3006	5
GasPromNeft	Ocean CSO 7	7
Gulf Oil Marine	GulfSea Superbear 3006	6
	GulfSea Superbear 3008	8
IndianOil	Servo Marine 0530	5
JX Nippon Oil & Energy	Marine S30	7
LUKOIL	Navigo 6 CO	6
Motor Oil Hellas	EMO Panoil M 530	5
Pertamina	Medripal 307	7
Petrobras	Marbrax CAD-308	8
PetroChina	KunLun DCC3008	8
Petronas	DISROL 5 LS30	5
Premier Six	Opt-Max Shieldguard 3008	8
Puma Energy	Marine System Oil TBN 5 SAE 30	5
Shell	Melina S30	5
SINOPEC	Marine System Oil 3005	5
	Marine System Oil 3006	6
	Marine System Oil 3008	8
SK	Supermar AS ¹	5
Total	Atlanta Marine D 3005	5

- 1 Multiple formulations of this product are available. Not all of them are validated. Speak to the supplier for more data about the validated products.

10 Do an analysis of the system oil

Periodicity

Description	
Working hours	3000
Working hours	6000
Duration for performing preliminary requirements	0.0 man-hours
Duration for performing the procedure	0.5 man-hours
Duration for performing the requirements after job completion	0.0 man-hours

Personnel

Description	Specialization	QTY
Engine crew	Basic	1

Support equipment

Description	Part No.	CSN	QTY
None			

Supplies

Description	QTY
Sample bottles	A/R

Spare Parts

Description	Part No.	CSN	QTY
None			

SAFETY PRECAUTIONS

CAUTION

Injury Hazard: The system oil is hot. Put on gloves and safety goggles to prevent injuries. Do the work carefully.

PRELIMINARY OPERATIONS

- The oil pump is running.
- The system oil has operating temperature.
- The periodicity of 3000 working hours applies for regular oil analysis.
- The periodicity of 6000 working hours applies for FZG and particle count analysis.

PROCEDURE

- 1 Flush the sample pipe.
NOTE: Use the sample point related to the engine as follows:
 - For an engine with servo oil filter, do as follows:
 - Get a sample from the sample point at the engine inlet.
 - If the analysis shows unusual values, get a sample from the sample point after the servo oil filter.
 - For an engine without servo oil filter, get the sample from the sample point at the engine inlet.
 - 1.1 Put an applicable container under the sample valve.
 - 1.2 Slowly open the sample valve to flush out oil and possible dirt.
 - 1.3 Close the sample valve.
 - 1.4 Discard the oil correctly.
- 2 Get an oil sample.
 - 2.1 Put the sample bottle under the sample valve.
 - 2.2 Slowly open the sample valve to fully fill the sample bottle.
NOTE: The necessary quantity of oil is as follows:
 - 100 ml for regular oil analysis
 - 5 l for FZG and particle count analysis.
 - 2.3 Close the sample valve.
 - 2.4 Close the sample bottle tight.
- 3 Write the data that follows on the sample bottle:
 - Name of the ship
 - Type and serial number of the engine
 - Date of the sampling
 - Location of the sample point
 - Operating hours of the oil and of the engine
 - Brand and type of the oil.
- 4 If applicable, do [Step 1](#) to [Step 3](#) again for the other sample point.
- 5 Send the sample bottles in an applicable package to a laboratory for analysis.
- 6 Do the procedures related to the results, refer to section [8 System oils](#) or to the document "Lubricants" on the WinGD website (<https://www.wingd.com/>).

CLOSE UP

- None

11 Different oils and lubricants

The engine uses different other oils and lubricants. WinGD recommends as follows:

- **Turbocharger oil**

To select the turbocharger lubricating oil and keep this oil in a satisfactory condition, refer to the recommendations given in the turbocharger instruction manual. The turbocharger lubricating oil is usually system oil or turbine oil.

- **Turning gear oil**

To select the turning gear oil and to keep this oil in a satisfactory condition, refer to the recommendations given in the instruction manual of the turning gear manufacturer.

- **Lubricants for flywheel and pinion gear teeth**

To select and apply the lubricants for flywheel and pinion gear teeth, refer to the recommendations from the engine manufacturer.

Suppliers of applicable lubricants for flywheel and pinion gear teeth are given in section [12 List of lubricants for flywheel and pinion gear teeth](#).

For other applicable lubricants speak to the lubricant supplier.

- **Environmentally acceptable lubricants**

Environmentally Acceptable Lubricants (EAL) are currently necessary for ships operating in USA waters, and this area may be extended in future.

These lubricants, which are necessary for all oil-to-sea interfaces (and include stern tubes, thrusters, rudders, stabilizers, variable pitch propellers, underwater ropes, machinery and underwater transmissions) are made with base oils and additives which are different to those used for system oils and cylinder oils.

Thus, EAL must not be mixed with system oils or cylinder oils. Contamination of EAL (related to base oil quality) in system oil or cylinder oil can cause different problems (for example elastomer compatibility, water emulsification, high temperature deposit formation).

12 List of lubricants for flywheel and pinion gear teeth

Always use lubricants for flywheel and pinion gear teeth related to the WinGD general lubricant specifications and recommendations given in the Operation Manual.

The oil supplier assumes all responsibility for the performance of the lubricant used to the exclusion of any liability of WinGD and of companies that are part of the WinGD group. The oil supplier along with other possible manufacturers and distributors of the related products shall indemnify, compensate and hold harmless WinGD and companies that are part of the WinGD group from and against any claims, damages and losses caused by the used lubricants.

Tab 9 List of lubricants for flywheel and pinion gear teeth (16 October 2012)

Supplier	Brand
Lubrication Engineers Inc.	LE 5182 PYROSHIELD
Klüber Lubrication München KG	Klüberfluid C-F 3 ULTRA