

WIN G&D

Winterthur Gas & Diesel

WIN G&D

RT-flex58T-D

Operation Manual

“Marine”

Version 2

Supply Unit Aft End

Vessel:

Type:

Engine No.:

Document ID:

Winterthur Gas & Diesel Ltd.
Schützenstrasse 1-3
CH-8400 Winterthur
Switzerland

24hrs Support:
Wärtsilä Services Switzerland Ltd.
Zürcherstrasse 12
CH 8400 Winterthur
Switzerland
+41 52 262 80 10
technicalsupport.chts@wartsila.com

© 2017-11 Winterthur Gas & Diesel Ltd., Printed in Switzerland – All rights reserved

No part of this publication may be reproduced or copied in any form or by any means (electronic, mechanical, graphic, photocopying, recording, taping or other information retrieval systems) without the prior written permission of the copyright holder.

Winterthur Gas & Diesel Ltd. or Wärtsilä Services Switzerland Ltd. make no representation, warranty (express or implied) in this publication and assumes no responsibility for the correctness, errors or omissions for information contained herein. Information in this publication is subject to change without notice.

NO LIABILITY WHETHER DIRECT, INDIRECT, SPECIAL, INCIDENTAL OR CONSEQUENTIAL, IS ASSUMED WITH RESPECT TO THE INFORMATION CONTAINED HEREIN. THIS PUBLICATION IS INTENDED FOR INFORMATION PURPOSES ONLY.

WIN G2

RT-flex58T-D

Operation Manual

“Marine”

Version 2

Supply Unit Aft End

Vessel:

Type:

Engine No.:

Document ID:

Winterthur Gas & Diesel Ltd.
Schützenstrasse 1-3
CH-8400 Winterthur
Switzerland

24hrs Support:
Wärtsilä Services Switzerland Ltd.
Zürcherstrasse 12
CH 8400 Winterthur
Switzerland
+41 52 262 80 10
technicalsupport.chts@wartsila.com

© 2017-11 Winterthur Gas & Diesel Ltd., Printed in Switzerland – All rights reserved

No part of this publication may be reproduced or copied in any form or by any means (electronic, mechanical, graphic, photocopying, recording, taping or other information retrieval systems) without the prior written permission of the copyright holder.

Winterthur Gas & Diesel Ltd. or Wärtsilä Services Switzerland Ltd. make no representation, warranty (express or implied) in this publication and assumes no responsibility for the correctness, errors or omissions for information contained herein. Information in this publication is subject to change without notice.

NO LIABILITY WHETHER DIRECT, INDIRECT, SPECIAL, INCIDENTAL OR CONSEQUENTIAL, IS ASSUMED WITH RESPECT TO THE INFORMATION CONTAINED HEREIN. THIS PUBLICATION IS INTENDED FOR INFORMATION PURPOSES ONLY.

RT-flex58T-D Version 2 Supply Unit Aft End				Summary for Operation Manual (OM)		
Page No.	Modification		Title	Subject	Page or Manual	
	Date	No.			new	exch.
	2013			Issue 2013	x	
				Date of publication 2013-02-27		
0250-2/A2	03-2014	EAAD084756	Operating Data Sheet	Values for PT2001A changed: -ALM from 4.0 bar to 3.6 bar -SLD from 3.8 bar to 3.4 bar Value for PS2002S changed: -SHD from 3.3 bar to 2.9bar		x
0850-1/A2			Failures and Defects of WECS Components	New chapter added	x	
				Date of publication 2014-03-21		
OM_2015-07	2015-07		Cover page, Disclaimer and all related pages	Data about Winterthur Gas & Diesel (WinGD) and Wartsila Services Switzerland (WSCH) added; New Layout WinGD; New disclaimer and data about WinGD and WSCH added;		x
0000-1/A1	2015-07		For Your Attention	Data updated (WinGD and WSCH added);		x
0020-1/A1	2015-07		Table of Contents	New Chapter 7218-3/A1 added		x
0030-1/A2	2015-07		Subject Index	New Chapter 7218-3/A1 added		x
0035-1/A2	2015-07	Service Bulletin RT-138 (Version 4)	Abbreviations	Abbreviations added		x
0210-1/A1	2015-07		Safety Precautions and Warnings	Chapter updated, new structure;		x
0270-1/A1	2015-07	Service Bulletin RT-82	Changing Over from Diesel Oil to Heavy Fuel Oil and Vice Versa	Temperature gradient changed from 15°C/min to 2°C/min related to the Service Bulletin;		x
0280-1/A2	2015-07	Service Bulletin RT-138 (Version 4)	Operation at Low Load	Reference to 0750-1 paragraph 3.3 added		x
0410-1/A2	2015-07	Service Bulletin RT-161	Running-in New Cylinder Liners and Piston Rings	Paragraph 1: Latest data from the Service Bulletin; Chapter updated: Controlled English Paragraph 1: latest data related to the Service Bulletin RT-161 added; Paragraph 5: Note updated; Running-in sequence diagram data about FPP and CPP removed;		x
0710-1/A1	2015-07	EAAD085468 Service Bulletin RT-126	Diesel Engine Fuels	Latest data from fuel specification added; Table 1: maximum sulfur value changed from 4.5 to 3.5 m/m[%]; Fig. 1: Viscosity/Temperature Diagram updated; Note 2) to Fig. 1: min. value for fuel viscosity changed from 13 cSt to 10 cSt; Table 2: Pour point (upper) winter max. value changed from 0 to -6; Carbon residue max. value removed; minor changes in the text; Data about Wartsila Service Switzerland Ltd and WinGD added;		x
0720-1/A1	2015-07	EAAD085468	Operating Media - Fuel Treatment and Fuel System	Fig. 1: Schematic Diagram - Fuel System updated; Key to Fig. 1: Items 31, 32, 33 added; para 3: minor text changes; para 4: text changed; data about additional leakage collection tank added; Structure of the document changed;		x

RT-flex58T-D Version 2 Supply Unit Aft End				Summary for Operation Manual (OM)		
Page No.	Modification		Title	Subject	Page or Manual	
	Date	No.			new	exch.
0750-1/A1	2015-07	Service Bulletins RT-138 (Version 4) RT-138_1 (Version 4) RT-161	Operating Media	paragraph 2.1: additional data added Table 1: data FZG gear machine test added Table 2: data FZG gear machine test added paragraph 2.4: Sample point added paragraph 3.1: updated Fig. 1: illustration updated paragraph 3.2: new data and Fig. 2 added paragraph 3.3: new paragraph added paragraph 3.4: new paragraph added paragraph 7: new paragraph added paragraph 8.1: new paragraph added paragraph 8.2: list of approved lubricating oils updated paragraph 8.3: new table added added Chapter updated (latest data from Revision 4 of the Service Bulletin RT-138); Fig. 1 and Fig. 2: new illustration with latest data; Table 4: List of Validated Lubricating Oils updated (latest data from January 2015); Table 5: List of Validated System Oils updated (latest data from January 2015);		x
6500-1/A1	2015-07	Service Bulletin RT-162	Turbocharging	Caution added (new data related to the Service Bulletin RT 162, Issue 1)		x
Group 7	2015-07		Group TOC	New Chapter 7218-3/A1 added		x
7218-3/A1	2015-07	Service Bulletin RT-161	Feed Rate - Adjustment	New Chapter added, related to the Service Bulletin RT-161	x	
8016-1/A3	2015-07	Service Bulletin RT-138	Lubricating Oil System	New data about taking dirty oil samples related to the Service Bulletin RT-138;		x
8016-1/A4	2015-07	Service Bulletin RT-138	Lubricating Oil System	New data about taking dirty oil samples related to the Service Bulletin RT-138;		x
				Date of publication 2015-07-21		
All pages	2017-11	Update WinGD	All documents	Engine brand changed from Wärtsilä to WinGD RT-flex58T-D		x
0250-1/A1	2017-04	Update WinGD	Operating Data Sheet Pressure and Temperature Ranges	Torsional vibration damper (damper inlet): Min. pressure value changed from 1.0 bar to 2.8 bar; max. pressure 5.0 bar (value added); Note added;		x
0250-2/A1	2017-04	Update WinGD	Operating Data Sheet Alarms and Safeguards	PT2711A: ALM value changed from 1.0 bar to 2.2 bar; Medium name changed to 'Torsional vibration damper oil (steel spring damper)'; Note added		x
				Date of publication 2017-11-16		

0 Operating Descriptions

1 Bedplate and Tie Rod

2 Cylinder Liner and Cylinder Cover

3 Crankshaft, Connecting Rod and Piston

4 Engine Control and Control Elements

5 Supply Unit, Servo Oil Pump and Fuel Pump

6 Scavenge Air System

7 Cylinder Lubrication

8 Piping Systems

9 Engine Monitoring

Intentionally blank

For Particular Attention 0000-1/A1

▽ **General**

- Preface 0010-1/A1
- Table of Contents 0020-1/A2
- Subject Index 0030-1/A2
- Guide for Abbreviations 0035-1/A2
- How to Use the Operating Manual 0040-1/A2
- Short Description of the Engine 0050-1/A2
- Working Principle of the Two-stroke Diesel Engine 0060-1/A1
- The Relation between Engine and Propeller 0070-1/A1
- Engine Numbering and Designations 0080-1/A1

▽ **Preparation before Taking into Service**

- Prepare the Engine before Start after a Short Shut-down (One or More Days) 0110-1/A2
- Prepare the Fuel Oil System for Operation 0120-1/A1
- Prepare the Servo Oil System 0130-1/A1
- Prepare the Cylinder Lubricating System 0140-1/A2

▽ **Operation during Usual Conditions**

- Summary 0200-1/A1
- Safety Precautions and Warnings (General Information) 0210-1/A1
- Slow Turning 0220-1/A1
- Starting 0230-1/A2
- Usual Operation 0240-1/A1

▽ **Operating Data Sheet**

- Pressure and Temperature Ranges at Continuous Service Power MCR 0250-1/A1
- Alarms and Safeguards at Continuous Service Power 0250-2/A2

▽ **Operation**

- Manoeuvring 0260-1/A1
- Change-over from Diesel Oil to Heavy Fuel Oil and Back 0270-1/A1
- Operation at Low Load 0280-1/A2
- Operation at Overload 0290-1/A1

Engine Shutdown

- General 0310-1/A1
- Procedures after Engine Stop 0320-1/A2

Special Procedures during Operation

- Running-in of New Cylinder Liners and Piston Rings 0410-1/A2
- Indicator Diagrams 0420-1/A1
- Procedures to Prevent Contamination and Fire in the Scavenge Air Spaces . 0450-1/A2
- Instructions Concerning the Prevention of Crankcase Explosions 0460-1/A1

▽ **Operation during Unusual Conditions**

- General Data 0500-1/A1
- Operation with Injection Cut Out (One or More Cylinders) 0510-1/A2
- Faults in High Pressure Fuel System 0515-1/A1
- Operation with Exhaust Valve Control Unit Cut Out 0520-1/A1
- Faults in Servo Oil System 0525-1/A1
- Operation without Crosshead Lubricating Oil Pump 0535-1/A1
- Operation with Running Gear Partially or Totally Removed 0540-1/A1
- Operation with Water Leakage into the Combustion Chamber 0545-1/A1
- Overpressure in the Combustion Chamber 0546-1/A1
- Scavenge Air Cooler Out of Service / Failure of Auxiliary Blowers 0550-1/A1
- Defective Remote Control 0560-1/A1
- Defect in Speed Control System 0570-1/A1
- Turbocharger Out of Service 0590-1/A1

▽ **Special Procedures before and after Operation**

- Procedures before Starting after a Long Shutdown Period
or an Overhaul 0610-1/A1
- Procedures before Putting Out of Service for a Long Period 0620-1/A2

▽ **Operating Media**

- Diesel Engine Fuels 0710-1/A1
- Fuel Treatment, Fuel Oil System 0720-1/A1
- Scavenge Air and Compressed Air 0740-1/A1
- Lubricating and Servo Oils 0750-1/A1
- Cooling Water / Cooling Water Treatment 0760-1/A1

▽ **Operating Problems**

- General 0800-1/A2
- Problems during Engine Start and Stop 0810-1/A1
- Irregular Functions during Operation 0820-1/A2
- Problems and Damage with Engine Parts 0840-1/A2
- Failures and Defects of WECS Components 0850-1/A2

For Particular Attention

1. General

This manual is for the operator and is for use only for the related type of diesel engine (the engine described in this manual). The data in this manual is confidential.

Make sure that you read carefully the Operation Manual before you operate the engine.

Make sure that you know the Inspection and Overhaul intervals in the Maintenance Manual before you operate the engine.

Make sure that you read the data in Group 0 in the Maintenance Manual before you do maintenance work on the engine.

2. Spare Parts

Use only original spare parts and components to make sure that the engine will continue to operate satisfactorily. All equipment and tools for maintenance and operation must be serviceable and in good condition.

The extent of all supplies and services is set exclusively to the related supply contract.

3. Data

The specifications and recommendations of the classification societies, which are essential for the design, are included in this manual.

The data, instructions, graphics and illustrations etc. in this manual are related to drawings from Winterthur Gas & Diesel Ltd. (WinGD). These data relate to the date of issue of the manual (the year of the issue is shown on the title page). All instructions, graphics and illustrations etc can change because of continuous new development and modifications.

4. Personnel

Only qualified personnel that have the applicable knowledge and training must do work on the engine, its systems and related auxiliary equipment.

Data related to protection against danger and damage to equipment are specified in this manual as Warnings and Cautions.

Intentionally blank

General

Preface

1. Summary

The documentation for this diesel engine type comprises the following books and publications:

1.1 Operating Manual

This contains data about engine operation, the required operating media (oil, water and fuel), as well as a description of the function of specific systems.

1.2 Maintenance Manual

This contains, in addition to the maintenance diagrams, information covering specific dismantling and assembly work necessary for engine maintenance. It contains furthermore a masses (weight) table of certain individual parts, a clearance table, a list of rubber / O-rings, tightening values for important screwed connections and a tools list.

1.3 Code Book (spare parts catalogue)

In this book all parts are marked with a code number by which they can be ordered from Wärtsilä Services Switzerland Ltd or the engine supplier. *Such spare parts are to be ordered exclusively from this book.*

1.4 Documentation for bought-out items

Separate publications are provided for those items on the engine supplied by outside manufacturers, such as turbocharger, automatic filter, torsional vibration damper, etc. In most cases these can also be used as a spare parts catalogue.

1.5 Records and drawings

With the first delivery of the documentation, the setting tables, shop trial documents and surveyor's certificates of the related engine and the schematic diagrams are also supplied.

2. Structure of the manuals

Generally the manuals have to be regarded as **Basic Manuals**. They describe particularly the standard engine with all cylinder numbers, alternative design executions and special equipment.

As a rule, in the case of alternative design executions the descriptions are divided into separate groups and clearly designated by the respective alternative names. This allows on one hand to quickly find with certainty the respective passages, on the other hand it allows the later removal of sheets of not supplied alternatives and special executions.

Further indications can be found under Explanation on the Use of the Operating Manual [0040-1](#).

Preface

2.1 Structure and page designations

The individual groups with their illustrations are divided according to the design groups whenever possible.

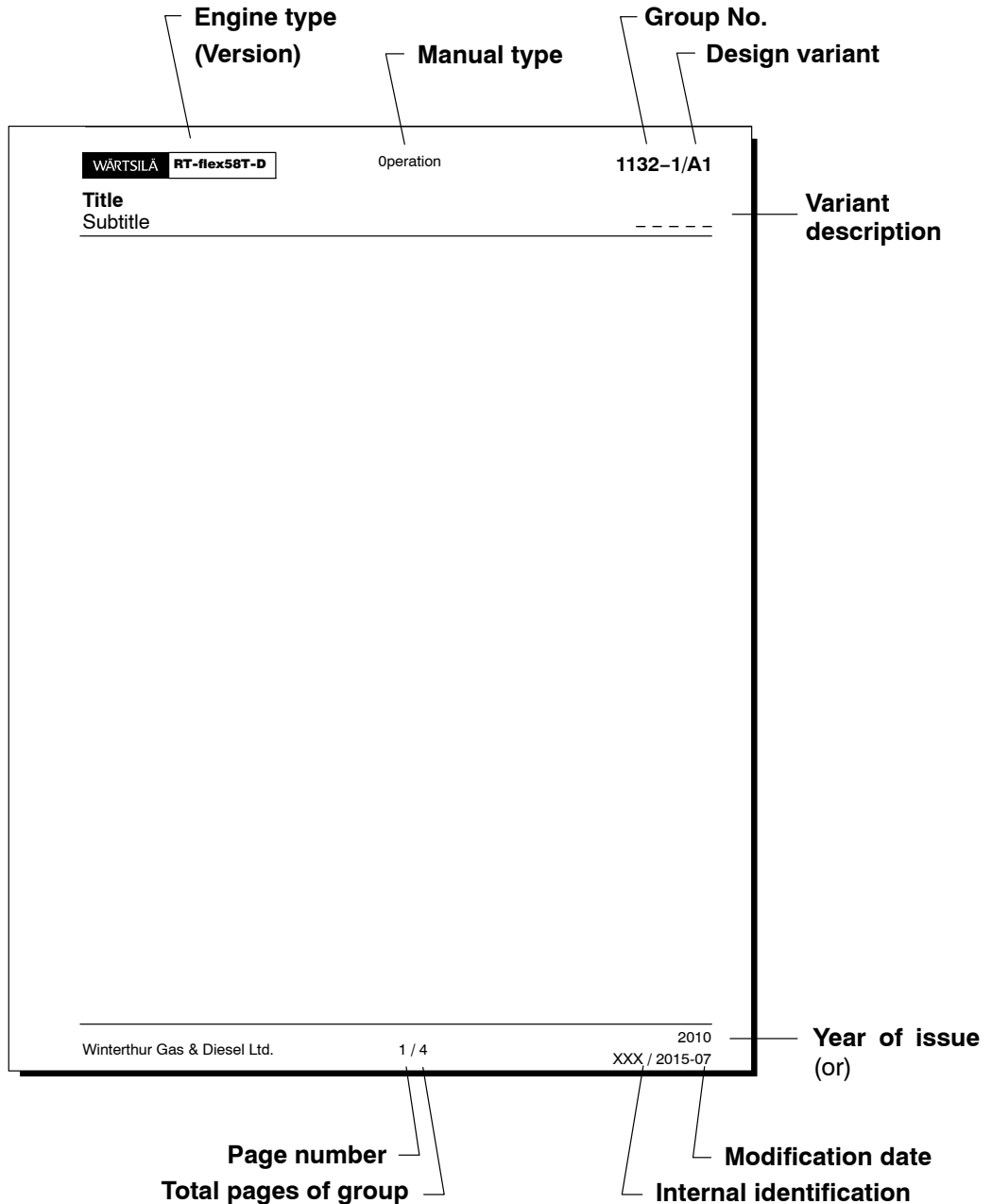

2.2 Symbols



Remark: Refers to important details and recommendations concerning operation and maintenance of the engine.

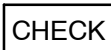

Refers to checks which must be carried out for trouble-free operation and during maintenance.

Preface



Attention! Risk of injury! or Risk of accident! Refers to instructions for operation and maintenance of the engine which absolutely must be complied with. In case of non-observance high risk of injury as well as damage to components must be expected.



Refers to activities which must **not** be carried out during operation and maintenance of the engine. In case of non-observance damage to components must be expected.

⇒ Sign for order of actions, activities to be carried out

- Sign for observance of regulations
- Sign for enumerations

3. Repeat-order of technical documentation



Remark: Corresponding to the continuing development of the engines the documentation is continually being updated.

This means that in a later ordered manual for the same engine, text and designations may no longer coincide in every way with the previous version (see modification date on the relevant pages).

Notwithstanding the foregoing, important information and improvements are brought to the customer's notice by 'Service Bulletins' so that the relevant part of any development should already be known.

When ordering documentation at a later stage for engines which have already been in operation since several years, the following details are basically required:

- Engine type, year of manufacture and engine manufacturer
- Name of vessel or site of installation
- Cylinder or engine number
- Special equipment
- Form of documentation (printed Manuals or CD-ROM)

Intentionally blank

Table of Contents

Operating Descriptions	Group 0
For Particular Attention	0000-1/A1
▽ General	
– Preface	0010-1/A1
– Subject Index	0030-1/A2
– Guide for Abbreviations	0035-1/A2
– How to Use the Operating Manual	0040-1/A2
– Short Description of the Engine	0050-1/A2
– Working Principle of the Two-stroke Diesel Engine	0060-1/A1
– The Relation between Engine and Propeller	0070-1/A1
– Engine Numbering and Designations	0080-1/A1
▽ Preparation before Taking into Service	
– Prepare the Engine before Start after a Short Shut-down (One or More Days)	0110-1/A2
– Prepare the Fuel Oil System for Operation	0120-1/A1
– Prepare the Servo Oil System	0130-1/A1
– Prepare the Cylinder Lubricating System	0140-1/A2
▽ Operation during Usual Conditions	
– Summary	0200-1/A1
– Safety Precautions and Warnings (General Information)	0210-1/A1
– Slow Turning	0220-1/A1
– Starting	0230-1/A2
– Usual Operation	0240-1/A1
▽ Operating Data Sheet	
– Pressure and Temperature Ranges at Continuous Service Power MCR	0250-1/A1
– Alarms and Safeguards at Continuous Service Power	0250-2/A2
▽ Operation	
– Manoeuvring	0260-1/A1
– Change-over from Diesel Oil to Heavy Fuel Oil and Back	0270-1/A1
– Operation at Low Load	0280-1/A2
– Operation at Overload	0290-1/A1
Engine Shutdown	
– General	0310-1/A1
– Procedures after Engine Stop	0320-1/A2
Special Procedures during Operation	
– Running-in of New Cylinder Liners and Piston Rings	0410-1/A2
– Indicator Diagrams	0420-1/A1
– Procedures to Prevent Contamination and Fire in the Scavenge Air Spaces ..	0450-1/A2
– Instructions Concerning the Prevention of Crankcase Explosions	0460-1/A1

 Table of Contents

 ▽ **Operation during Unusual Conditions**

- General Data	0500-1/A1
- Operation with Injection Cut Out (One or More Cylinders)	0510-1/A2
- Faults in High Pressure Fuel System	0515-1/A1
- Operation with Exhaust Valve Control Unit Cut Out	0520-1/A1
- Faults in Servo Oil System	0525-1/A1
- Operation without Crosshead Lubricating Oil Pump	0535-1/A1
- Operation with Running Gear Partially or Totally Removed	0540-1/A1
- Operation with Water Leakage into the Combustion Chamber	0545-1/A1
- Overpressure in the Combustion Chamber	0546-1/A1
- Scavenge Air Cooler Out of Service / Failure of Auxiliary Blowers	0550-1/A1
- Defective Remote Control	0560-1/A1
- Defect in Speed Control System	0570-1/A1
- Turbocharger Out of Service	0590-1/A1

 ▽ **Special Procedures before and after Operation**

- Procedures before Starting after a Long Shutdown Period or an Overhaul	0610-1/A1
- Procedures before Putting Out of Service for a Long Period	0620-1/A2

 ▽ **Operating Media**

- Diesel Engine Fuels	0710-1/A1
- Fuel Treatment, Fuel Oil System	0720-1/A1
- Scavenge Air and Compressed Air	0740-1/A1
- Lubricating and Servo Oils	0750-1/A1
- Cooling Water / Cooling Water Treatment	0760-1/A1

 ▽ **Operating Problems**

- General	0800-1/A2
- Problems during Engine Start and Stop	0810-1/A1
- Irregular Functions during Operation	0820-1/A2
- Problems and Damage with Engine Parts	0840-1/A2
- Failures and Defects of WECS Components	0850-1/A2

Bedplate and Tie Rod
Group 1

Main Bearing	1132-1/A1
Thrust Bearing	1203-1/A1
Tie Rod	1903-1/A1

Table of Contents

Cylinder Liner and Cylinder Cover	Group 2
Cylinder Liner	2124-1/A3
Lubricating Quills on Cylinder Liner	2138-1/A2
Piston Rod Gland Box	2303-1/A1
Injection Valve	2722-1/A1
Starting Air Valve	2728-1/A1
Exhaust Valve	2751-1/A3
Crankshaft, Connecting Rod and Piston	Group 3
Axial Damper	3140-1/A1
Connecting Rod and Connecting Rod Bearing	3303-1/A1
Crosshead and Guide Shoe	3326-1/A1
▽ Piston	
- with Four Piston Rings	3403-1/A1
- with Three Piston Rings	3403-1/A2
Crosshead Lubrication and Piston Cooling	3603-1/A1
Engine Control and Control Elements	Group 4
▽ Engine Control	
- Engine Control System WECS-9520	4002-1/A2
- User Parameters and Maintenance Settings	4002-3/A2
- Regular Checks and Recommended Procedures for WECS-9520	4002-4/A2
- Engine Control	4003-1/A2
▽ Control Diagram	
- Designations (Description to 4003-1, 4003-2 and 4003-3)	4003-2/A0
- Control Diagram	4003-2/A3
▽ Control and Auxiliary Systems	
- Detailed Control Diagrams with Interfaces to the Plant	4003-3/A3
Drive Supply Unit	4104-1/A1
Shut-off Valve for Starting Air	4325-1/A1
Control Air Supply	4605-1/A1
Local Control Panel	4618-1/A1
Pick-up for Speed Measurement	4628-1/A1

Table of Contents

Supply Unit, Servo Oil Pump and Fuel Pump	Group 5
Servo Oil Pump	5551-1/A1
Supply Unit	5552-1/A1
Fuel Pump	5556-1/A1
Cutting Out and Cutting In of the Fuel Pump	5556-2/A1
Fuel Pressure Control Valve 3.06	5562-1/A1
Regulating Linkage	5801-1/A1
Scavenge Air System	Group 6
Scavenge Air Receiver	6420-1/A1
Turbocharging	6500-1/A1
▽ Cleaning the Turbocharger in Operation	
– Turbocharger TPL Type	6510-1/A1
– Turbocharger MET Type	6510-1/A2
– Turbocharger A100-L Type	6510-1/A3
Auxiliary Blower and Switch Box	6545-1/A1
Scavenge Air Cooler: Operating Instructions and Cleaning	6606-1/A1
Piping Systems	Group 7
Cylinder Lubrication	7218-1/A2
Instructions Concerning Measurement of Cylinder Lubricating Oil Consumption	7218-2/A2
Feed Rate – Adjustment	7218-3/A1
Piping Systems	Group 8
▽ Lubricating Oil System	
– Turbocharger TPL and A100-L Type	8016-1/A3
– Turbocharger MET Type	8016-1/A4
Cooling Water System	8017-1/A1
Starting Air Diagram	8018-1/A1
Fuel System	8019-1/A1
Exhaust Waste Gate (Low-load Tuning)	8135-1/A1
Drainage System and Wash-water Piping System	8345-1/A1
Engine Monitoring	Group 9
Instrument Panel	9215-1/A1
Crank Angle Sensor Unit	9223-1/A1
Pressure Switches and Pressure Transmitters	9258-1/A1
Intelligent Combustion Control	9308-1/A1
Oil Mist Detector	9314-1/A1
Location of flex Electronic Components	9362-1/A2

Subject Index

Alphabetical Table of Contents

A

Abbreviations	0035-1/A2
Adjustment, Feed Rate –	7218-3/A1
Air flaps in the scavenge air receiver	6420-1/A1
Alarms and safeguards at continuous service power	0250-2/A2
Auxiliary blower and switch box	6545-1/A1
Auxiliary blower, failure of... ..	0550-1/A1
Auxiliary systems, control diagrams	4003-3/A3

C

Changeover from diesel oil to heavy fuel oil back	0270-1/A1
Checking engine controls	4003-1/A2
Checks and recommended procedures for WECS-9520	4002-4/A2
Cleaning the cooling system	0760-1/A1
Cleaning the scavenge air cooler in operation	6606-1/A1
Cleaning turbocharger (TPL type) in operation	6510-1/A1
Cleaning turbocharger (MET type) in operation	6510-1/A2
Cleaning turbocharger (A100-L type) in operation	6510-1/A3
Combustion chamber, overpressure	0546-1/A1
Combustion Control	9308-1/A1
Compressed air, starting air, control air	0740-1/A1
Control air supply	4605-1/A1
Control diagram, designations	4003-2/A0
Control diagram	4003-2/A3
Connecting rod, connecting rod bearing	3303-1/A1
Cooling water system	8017-1/A1
Cooling water treatment	0760-1/A1
Crank angle sensor unit	9223-1/A1
Crankcase explosions, prevention of... ..	0460-1/A1
Crosshead and guide shoe	3326-1/A1
Crosshead lubrication and piston cooling	3603-1/A1
Crosshead lubricating oil pump, operation without... ..	0535-1/A1
Cutting out and cutting in of the fuel pump	5556-2/A1
Cut out an exhaust valve control unit	0520-1/A1
Cylinder liner	2124-1/A3
Cylinder liner, running-in of new... ..	0410-1/A2
Cylinder lubrication, Feed Rate – Adjustment	7218-3/A1
Cylinder lubricating oil consumption, Instructions	7218-2/A2
Cylinder lubrication system, control	7218-1/A2
Cylinder lubricating system, preparation before taking into service ..	0140-1/A2

D

Damage to engine parts	0840-1/A2
Defective auxiliary blowers	0550-1/A1
Defective remote control	0560-1/A1
Drainage system and wash-water piping system	8345-1/A1
Drive supply unit	4104-1/A1

Alphabetical Table of Contents

E

Emergency lubrication for cylinder	7218-1/A2
Emergency operation with exhaust valve closed / opened	0520-1/A1
Engine, short description of... ..	0050-1/A2
Engine control	4003-1/A2
Engine control system WECS-9520	4002-1/A2
Engine numbering and designations	0080-1/A1
Engine preservation	0620-1/A2
Exhaust valve	2751-1/A2
Exhaust valve control unit, cut out	0520-1/A1

F

Failures codes in WECS-9520	0850-1/A2
Feed Rate - Adjustment	7218-3/A1
Fuel system, faults	0515-1/A1
Filling and draining of lubricating and servo oil system	8016-1/A3, A4
Finding group and page numbers	0040-1/A2
Fire in scavenge air spaces, prevention of... ..	0450-1/A2
For particular attention	0000-1/A1
Fuels for diesel engine	0710-1/A1
Fuel leakage system	8019-1/A1
Fuel system	8019-1/A1
Fuel system, faults	0515-1/A1
Fuel system, preparation... ..	0120-1/A1
Fuel pressure control valve 3.06	5562-1/A1
Fuel pump, cutting out and in	5556-2/A1
Fuel pump	5556-1/A1
Fuel treatment, fuel system	0720-1/A1

G

General indications for operation	0210-1/A1
Guide for symbols and abbreviations	0035-1/A2
Guide shoe on crosshead	3326-1/A1

H

Heavy fuel oil, quality requirements	0710-1/A1
Heavy fuel oil, treatment	0720-1/A1

I

Indicator diagrams	0420-1/A1
Injection cut out (one or more cylinders)	0510-1/A2
Injection valve	2722-1/A1
Interfaces to the plant, control diagrams	4003-3/A3
Instrument panel	9215-1/A1
Irregular functions during operation	0820-1/A2

Alphabetical Table of Contents

L

Leakage and wash-water piping system	8345-1/A1
Leakage inspection point (servo oil)	8016-1/A3, A4
Leakage monitoring (fuel)	8019-1/A1
LED indications on ALM-20 module	7218-1/A2
LED indications on FCM-20 module	0850-1/A2
Local control panel	4618-1/A1
Lubrication of exhaust valve spindle	7218-1/A2
Location of flex electronic components	9362-1/A2
Lubricating and servo oils	0750-1/A1
Lubricating oil system (turbocharger TPL and A100-L type)	8016-1/A3
Lubricating oil system (turbocharger MET type)	8016-1/A4
Lubricating quills	2138-1/A2
Lubrication of cylinder liner	7218-1/A2

M

Main bearing	1132-1/A1
Manoeuvring	0260-1/A1

O

Oil consumption of cylinder lubricating, determination	7218-2/A2
Oil mist detector with sensor design	9314-1/A1
Operating data sheet, alarms and safeguards	0250-2/A2
Operating data sheet, pressure and temperature ranges	0250-1/A1
Operating manual, how to use	0040-1/A2
Operating medium, air	0740-1/A1
Operating medium, oil	0750-1/A1
Operating medium, water	0760-1/A1
Operating problems, general	0800-1/A2
Operating with defective turbocharger	0590-1/A1
Operation at low load	0280-1/A2
Operation at overload	0290-1/A1
Operation during usual conditions, general information	0210-1/A1
Operation during usual conditions, summary	0200-1/A1
Operation interruption, procedures before extended standstill	0620-1/A2
Operation during unusual conditions, general data	0500-1/A1
Operation under breakdown conditions	0500-1/A1 to 0590-1/A1
Overpressure in the combustion chamber	0546-1/A1

Alphabetical Table of Contents

P

Pick-up for speed measurement	4628-1/A1
Piping systems	Group 8
Piston	3403-1/A1
Piston and piston rings, running-in of cylinder liner	0410-1/A2
Piston rod gland	2303-1/A1
Precautionary procedures for operation	0210-1/A1
Preface	0010-1/A1
Prepare the fuel oil system for operation	0120-1/A1
Prepare the servo oil system	0130-1/A1
Preparation before taking into service	0110-1/A2
Problems during operation	0820-1/A2
Problems during engine start and stop	0810-1/A1
Problems with engine parts (damage)	0840-1/A2
Preservation of Engine	0620-1/A2
Pressure and temperature ranges	0250-1/A1
Pressure switch and pressure transmitter	9258-1/A1
Prevention of crankcase explosions	0460-1/A1
Propeller curve	0070-1/A1
Procedures to be taken after shutting down	0320-1/A2
Procedures to be taken before starting	0110-1/A2
Prevent contamination and fire in the scavenge air space	0450-1/A2

R

Regulating linkage	5801-1/A1
Replacement of a shut off exhaust valve control unit	0520-1/A1
Replacement of the injection control unit	0510-1/A2
Replacement of a defective hydraulic piping	0520-1/A1
Replacement of filter element (cylinder lubrication)	7218-1/A2
Requirements for heavy fuel oil	0710-1/A1
Remote control system defective	0560-1/A1
Running gear, operation with removed...	0540-1/A1
Running-in of new cylinder liner and piston rings	0410-1/A2

S

Safety precautions and warnings (general information)	0210-1/A1
Scavenge air and compressed air	0740-1/A1
Scavenge air cooler, operating instructions and cleaning	6606-1/A1
Scavenge air cooler out of service, failure of auxiliary blower	0550-1/A1
Scavenge air receiver	6420-1/A1
Servo oil leakage system	8016-1/A3, A4
Servo oil pump	5551-1/A1
Servo oil service pump	8016-1/A3, A4
Servo oil system, faults	0525-1/A1
Short description of the engine	0050-1/A2
Shutdown, general	0310-1/A1
Shutdown, procedure after engine stop	0320-1/A2
Shut-off valve for starting air	4325-1/A1

Alphabetical Table of Contents

Slow turning	0220-1/A1
Speed control system defective	0570-1/A1
Speed measurement, pick-up for... ..	4628-1/A1
Starting	0230-1/A2
Starting after long shutdown period or overhaul	0610-1/A1
Starting air system, schematic diagram	8018-1/A1
Starting valve	2728-1/A1
Structure of the manual	0010-1/A1
Supply unit	5552-1/A1
Symbols	0010-1/A1

T

Table of contents	0020-1/A2
Thrust bearing	1203-1/A1
The relation between engine and propeller	0070-1/A1
Tie rod	1903-1/A1
Turbocharger (TPL type), cleaning in service	6510-1/A1
Turbocharger (MET type), cleaning in service	6510-1/A2
Turbocharger (A100-L type), cleaning in service	6510-1/A3
Turbocharger out of service	0590-1/A1
Turbocharger surging	0820-1/A2
Turbocharging	6500-1/A1

U

Unusual operating condition	0500-1/A1
User parameters and maintenance settings	4002-3/A2
Usual operation	0240-1/A1

V

Venting and leak test of fuel system on engine	0120-1/A1
Venting the lubricating pump (cylinder lubrication)	7218-1/A2
Viscosity-temperature diagram	0710-1/A1

W

Warnings and safety measures (general)	0210-1/A1
Wash-water piping system	8345-1/A1
Water leakage into the combustion chamber	0545-1/A1
Water, operating medium... ..	0760-1/A1
WECS-9520 components, failures and defects of... ..	0850-1/A2
WECS-9520 engine control system	4002-1/A2
WECS-9520 manual control panel	4618-1/A1
Working principle of two-stroke diesel engine	0060-1/A1

Intentionally blank

Guide for Symbols and Abbreviations

1. Symbols

These stand for control components (valve units etc.) used for engine control.

Symbols	Explanations
A	Control air supply unit
B	Fuel supply
C	Fuel injection
D	Servo oil supply
E	Valve unit for start
F	Exhaust valve drive
H	Instrument panel
I	Pressure switches and pressure transmitters
K	Local control panel

2. Abbreviations

2.1 General

The abbreviations used in the manuals are arranged alphabetically in this guide, however, unit of measures are not listed.



Remark: Identical abbreviations e.g. MCR can be distinguished in the corresponding context.

Abbreviations	Explanations
AHD	Ahead
ALM	Alarm
AST	Astern
ASTM	American Society for Testing and Materials
BDC	Bottom Dead Center
BFO	Bunker Fuel Oil
BN	Base Number
BSFC	Brake Specific Fuel Consumption
CCAI	Calculated Carbon Aromaticity Index
CMCR	Contract Maximum Continuous Rating
COC	Cleveland Open Cup
EAL	Environmentally Acceptable Lubricants
ECA	Emission Control Area
HFO	Heavy Fuel Oil
IMO	International Maritime Organisation
ISO	International Standard Organisation
JIS	Japanese Industrial Standards
LSHFO	Low Sulphur Heavy Fuel Oil
MARPOL	International Convention for the Prevention of Pollution from Ships

Guide for Symbols and Abbreviations

Abbreviations	Explanations
MCR	Maximum Continuous Rating
MCR	Micro Carbon Residue
MDO	Marine Diesel Oil
mep	mean effective pressure
MGO	Marine Gas Oil
PMCC	Pensky Martens Closed Cup method
RCS	Remote Control System
SCR	Selective Catalytic Reduction
SHD	SHut Down
SHF	Sediment by Hot Filtration
SIPWA-TP	Sulzer Integrated Piston ring Wear detecting Arrangement with Trend Processing
SLD	SLow Down
TDC	Top Dead Center

2.2 Concerning engine control system WECS-9520

Abbreviations	Explanations
ACM-20	Angle Calculation Module-20
ALM-20	Advanced Lubrication Module-20
AMS	Alarm and Monitoring System
CAN-Bus	Controller Area Network
CAN M	CAN Modul bus
CAN S	CAN System bus
COM-FN	COMon FuNction (engine-related control functions)
CYL-FN	CYLinder FuNction (cylinder-related control functions)
DENIS-9520	Diesel Engine CoNtrol and OptImizing Specification for WECS-9520
ECR	Engine Control Room
FCM-20	Flex Control Module-20
FQS	Fuel Quality Setting
LED	Light Emitting Diode
SCS	Speed Control System
Modbus	Gould-Modicon Fieldbus
OPI	OPerator Interface (user interface in control room)
PCS	Propulsion Control System
RCS	Remote Control System
SIB	Shipyards Interface Box (engine / remote control interface)
SSI	Synchron Serial Interface
VEC	Variable Exhaust valve Closing
VEO	Variable Exhaust valve Opening
VIT	Variable Injection Timing
WECS	Wärtsilä Engine Control System
WECS-9520	Computerized control system for all flex-specific functions

General

How to Use the Operating Manual

1. Contents

The Operating Manual, (Operation), contains data and indications about:

- The servicing of the engine during operation.
- The necessary media (oil, water, air, fuel).
- The functions of components and systems.



Remark: The maintenance and overhaul instructions are found in the Maintenance Manual.

2. Where to find what

You can find the group titles in the Table of Contents [0020-1](#). You can also look in the Subject Index [0030-1](#).

In the cross section and longitudinal section illustrations, important components are shown with their group numbers. These group numbers have hyperlinks to the different groups in the manual, which give more data about the engine.

The cross section and longitudinal section illustrations shown below can have small differences because of different engine revisions.

3. Abbreviations

The abbreviations used in the Operation Manual are given in [0035-1](#). Abbreviations used in illustrations are shown in the related keys.

How to Use the Operating Manual

Cross Section

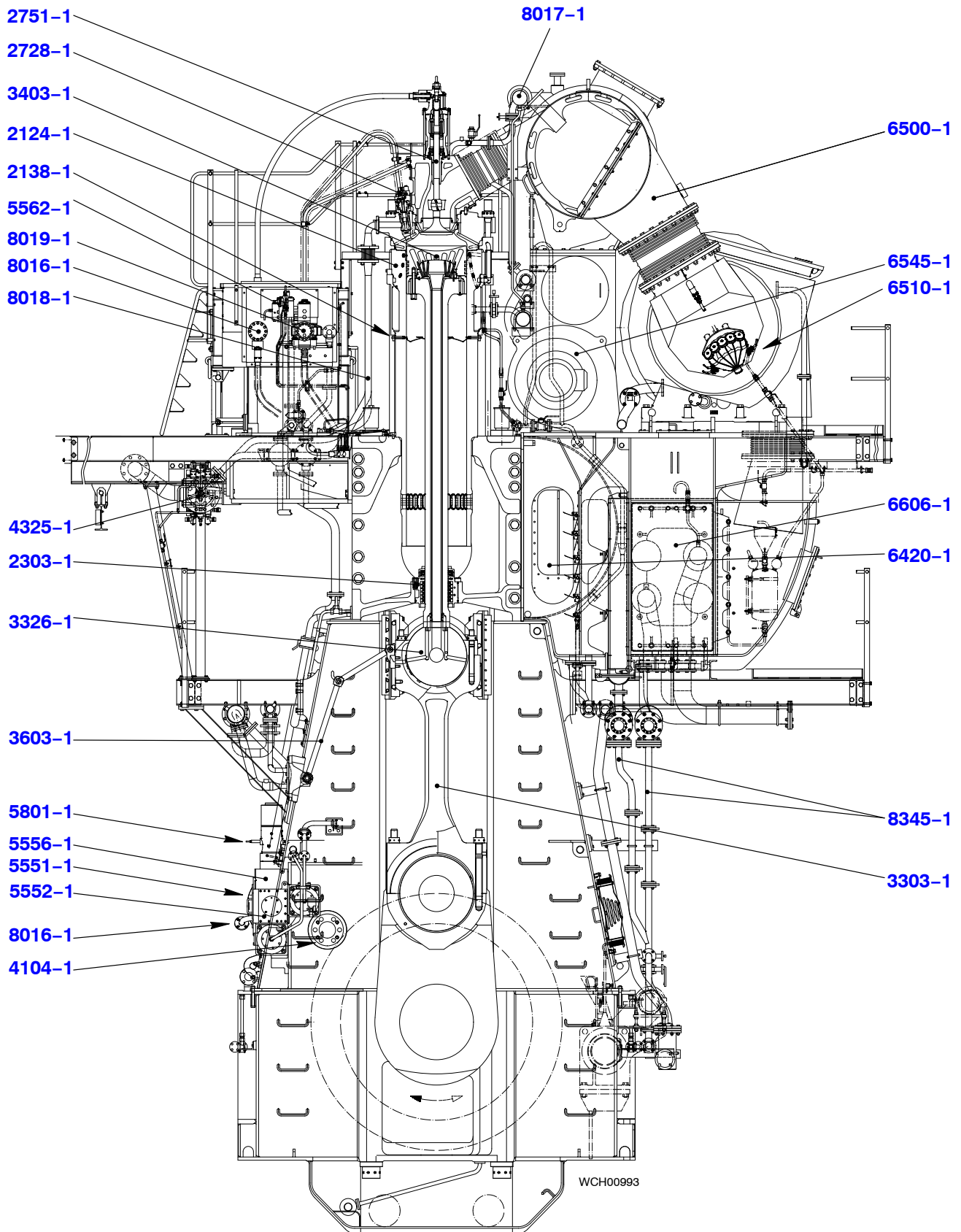

How to Use the Operating Manual

Longitudinal Section

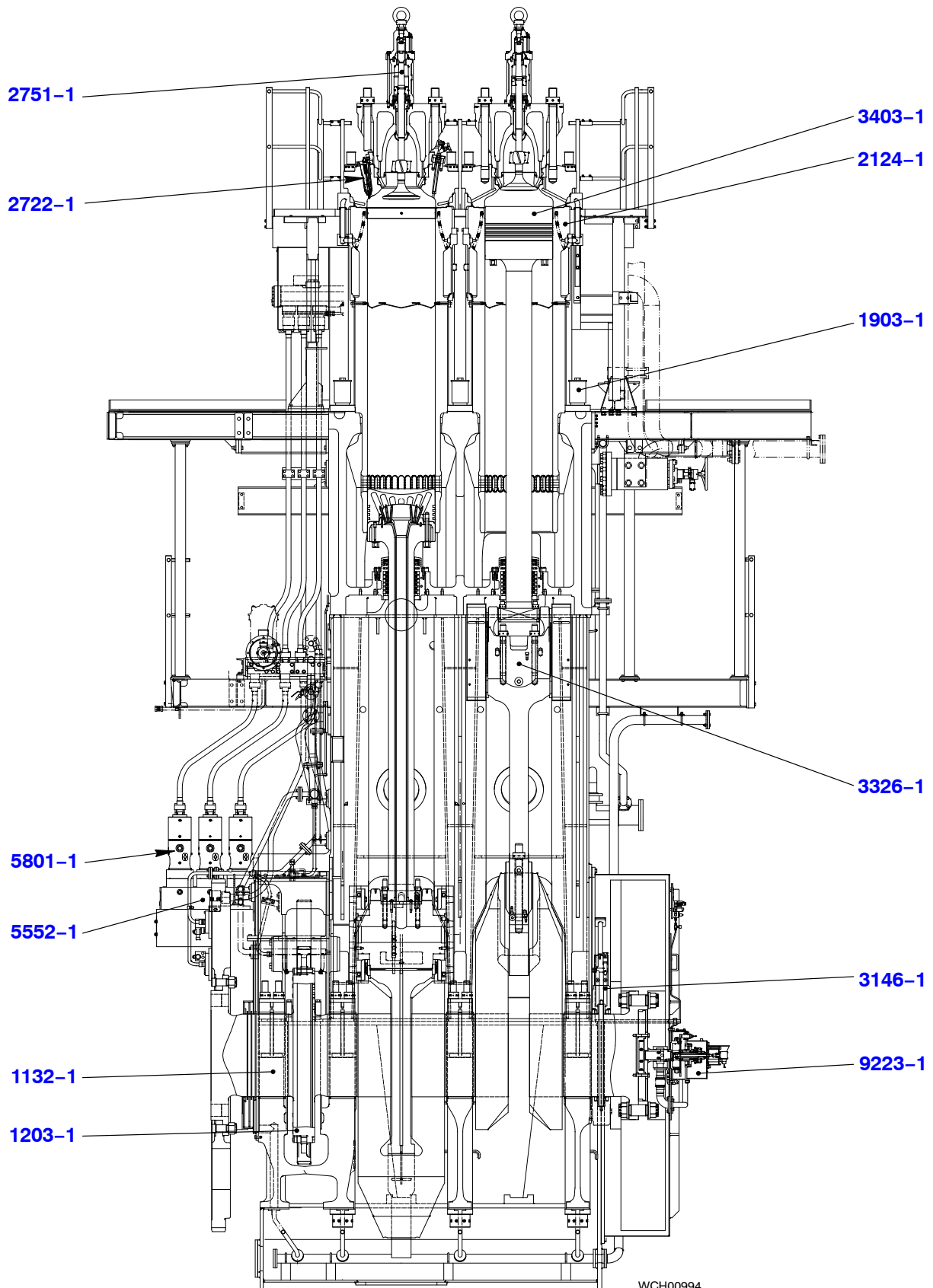

WCH00994

Intentionally blank

General

Short Description of the Engine

1. General

General data about the engine are given as follows:

- The RT-flex engine is a single acting two-stroke diesel engine of crosshead design with exhaust gas turbocharging and uniflow scavenging.
- The engine is reversible and is directly connected to the propeller.
- The RT-flex concept is based on the Wärtsilä Common Rail, with full electronic control of fuel injection and exhaust valve operation.
- The engine control can have different remote controls, which are related to our specifications, from recommended manufacturers.
- If the remote control has a failure, the engine can be controlled with the emergency control from the local control panel.
- Tie rods hold the bedplate, columns and cylinder block together.
- A partition isolates the crankcase from the cylinder block. This partition includes the piston rod glands for the piston rods.
- The thrust bearing and turning gear are installed on the driving end of the engine.
- The engine control system WECS-9520 controls the exhaust valve operation, the electronic fuel injection and the cylinder lubricating system.
- The lubrication oil, coolant water, fuel supply, booster pumps and air compressors are parts of the engine room installation (ancillary systems).

2. Systems

General data about the systems are given as follows:

- The servo oil system opens the exhaust valves hydraulically. The exhaust valves are closed pneumatically.
- Servo oil pumps in the supply unit supply bearing oil at the necessary pressure through two high pressure (HP) fuel pipes to the servo oil rail.
- Bearing oil cools the pistons.
- The fuel pumps in the supply unit supply high pressure fuel through the HP fuel pipes to the fuel rail. The fuel rail supplies fuel at high pressure to all the injection valves.
- The servo oil system operates the injection control units.
- Fresh water cools the cylinder liners and cylinder covers.
- The central fresh water cooling system (closed circuit), or the conventional sea-water cooling system (direct) with single-stage coolers are used to cool the scavenge air.
- The WECS-9520 controls the engine start sequence. Compressed air flows through the starting valve into the cylinders to start the engine.
- The exhaust gases flow from the cylinders through the exhaust valves into an exhaust gas manifold.
- The exhaust gas turbochargers operate on the constant pressure charging principle.
- The scavenge air from the turbocharger flows through the air cooler and water separator into the air receiver. This air then flows through air flaps and scavenge ports when the pistons are almost at BDC.
- At low loads, independently operated auxiliary blowers supply air to the scavenge air space.

Intentionally blank

General**Working Principle of the Two-stroke Diesel Engine**

First Stroke (Compression):

- The piston is at Bottom Dead Center (BDC).
- The scavenge ports and exhaust valve open.
- Scavenge air flows into the cylinder and pushes the exhaust gases through the exhaust valve into the exhaust gas manifold and then to the turbocharger.
- The piston moves up.

Point ES:

- The piston covers the scavenge ports.

Point AS:

- The exhaust valve closes and compression starts, which heats the air.

Second Stroke (Ignition – Combustion – Expansion – Exhaust – Scavenging):

- When the piston is almost at Top Dead Centre (TDC), fuel is injected into the cylinder.
- The fuel ignites in the compressed, heated air and then combustion starts.
- The gases expand and push the piston down (working stroke).

Point AO:

- The exhaust valve opens, exhaust gas flows out of the cylinder into the exhaust gas manifold.

Point EO:

- The piston continues to move down to let air in through the scavenge ports.
- Scavenge air flows into the cylinder and pushes the exhaust gas through the exhaust valve into the exhaust gas manifold and then to the turbocharger.

(See also the schematic diagram of Turbocharging [6500-1](#)).

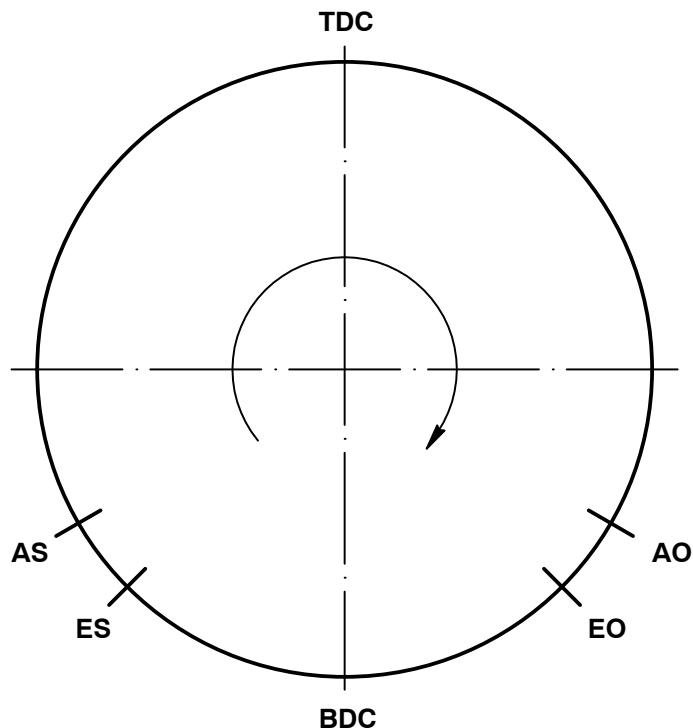

Intentionally blank

General

The Relation between Engine and Propeller

1. General

There is a specified relation between the propeller speed and the absorbed power in ships that have fixed pitch propellers. The relation is between the propeller and the speed at which it turns.

The formula that follows gives an approximate result, which is sufficient for conventional vessels:

$$\frac{P_1}{P_2} = \left(\frac{n_1}{n_2} \right)^3$$

The graph from this formula is known as the propeller characteristic.

If the engine is in good condition, correctly supplied with air (i.e. turbocharger(s) are in good condition and the resistance of the air and exhaust lines is within the specifications) and the fuel injection quantity is correctly adjusted (see the shoptest protocol), then the mean effective pressure (mep) developed under service conditions (in accordance with the specified load indication), is related to the approximate mep for this particular position on the test bed.

In the diagram (see paragraph 2), the propeller characteristic line through the CMCR point (100% power at 100% engine speed) is known as the nominal propeller characteristic. Engines which are to be used for the propulsion of vessels with fixed propellers have a load applied on the test bed in accordance with this propeller characteristic. However, during sea trial of a new ship with a smooth and clean hull, the power requirement is lower and the operation point is below the nominal propeller characteristic.

During service, a higher torque will be necessary for the propeller to keep its speed than at the time of the sea trial (sea margin) because:

- there are changes in wake flow conditions because of marine growth on the hull
- the cargo load has an effect on the depth of the vessel in the water
- the propeller has a rough surface or has mechanical damage
- the vessel operates in bad sea and weather conditions
- the vessel operates in shallow water.

The mep of the engine (and thus the fuel injection quantity) will increase. In such a condition, the operating point will then be at the left of the initial propeller curve which was calculated during sea trials.

Although a cleaned and repainted hull will help to decrease the resistance of the hull. It is not possible, however, to get the hull back to its initial condition.

Because the thermal load of the engine is related to the mep, the position of the operating point is also important. The air supply to the engine and the operating conditions will become unsatisfactory if the operation point is far above from the propeller curve.

To get the best conditions, the operation point of the engine for service range must be on or below the nominal propeller characteristic.

Explanations:

CMCR	=	Contract Maximum Continuous Rating
P	=	Power
n	=	speed
mep	=	mean effective pressure

The Relation between Engine and Propeller

2. Fixed Pitch Propeller (FPP)

2.1 Continuous service rating (CSR)

Point **A** represents power and speed of a ship operating at contractual speed in calm seas with a new clean hull and propeller. The same ship at the same speed requires a power / speed combination according to point **D**, shown in the figure below, under service condition with aged hull and average weather. Point **D** is then the CSR-point.

2.2 Engine margin (EM) / operational margin (OM)

Most owners specify the contractual ship's loaded service speed at 85% ... 90% of the contract maximum continuous rating. The remaining 10% to 15% power can be utilized to catch up with delays in schedule or for the timing of dry-docking intervals. This margin is usually deducted from the CMCR. Therefore, the 100% power line is found by dividing the power at point **D** by 0.85 ... 0.90.

Load range limits with load diagram of an engine corresponding to a specific rating point Rx:

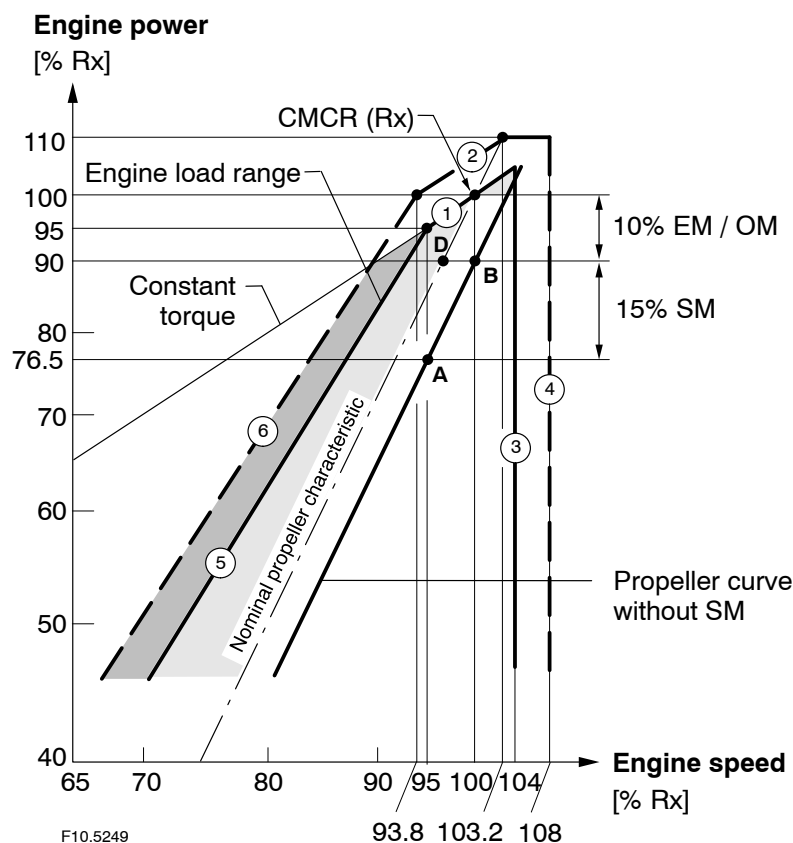

Key to Illustration:

- EM Engine margin
- OM Operational margin
- SM Sea margin

The Relation between Engine and Propeller

2.3 Load range limits

Once the engine is optimized at (CMCR (Rx), the working range of the engine is limited by the following border lines:

- **Line 1** is a constant mep or torque line through CMCR from 100% speed and power down to 95% power and speed.
- **Line 2** is the overload limit. It is a constant mep line reaching from 100% power and 93.8% speed to 110% power and 103.2% speed. The latter one is the point of intersection between the nominal propeller characteristic and 110% power.
- **Line 3** is the 104% speed limit where an engine can run continuously. For Rx with reduced speed ($N_{CMCR} \leq 0.98 N_{MCR}$) this limit can be extended to 106%, however, the specified torsional vibration limits must not be exceeded.
- **Line 4** is the overspeed limit. The overspeed range between 104 (106) and 108% speed is only permissible during sea trails if needed to demonstrate the ship's speed at CMCR power with a light running propeller in the presence of authorized representatives of the engine builder. However, the specified torsional vibration limits must not be exceeded.
- **Line 5** represents the admissible torque limit and reaches from 95% power and speed to 45% power and 70% speed. This represents a curve defined by the equation: $P_2/P_1 = (N_2/N_1)^{2.45}$. When approaching the line 5, the engine will increasingly suffer from lack of scavenge air and its consequences. The area formed by lines 1, 3 and 5 represents the range within which the engine should be operated. The area limited by the nominal propeller characteristic, 100% power and line 3 is recommended for continuous operation. The area between the nominal propeller characteristic and line 5 has to be reserved for acceleration, shallow water and normal operational flexibility.
- **Line 6** is defined by the equation: $P_2/P_1 = (N_2/N_1)^{2.45}$ through 100% power and 93.8% speed and the maximum torque limit in transient conditions. The area above line 1 is the overload range. It is only allowed to operate the engines in that range for maximum duration of one hour during sea trails in the presence of authorized representatives of the engine builder. The area between lines 5 and 6 and constant torque line (shown as a dark area) should only be used for transient conditions, i.e. during fast acceleration. This range is called 'service range with operational time limit'.

The Relation between Engine and Propeller

3. Controllable Pitch Propeller (CPP)

3.1 Load ranges

After engine start, the engine is operated at an idle speed of up to 70% of the rated engine speed with zero pitch. From idle speed, the propeller pitch is to be increased with constant engine speed up to at least point **E**, the intersection with the line **9**.

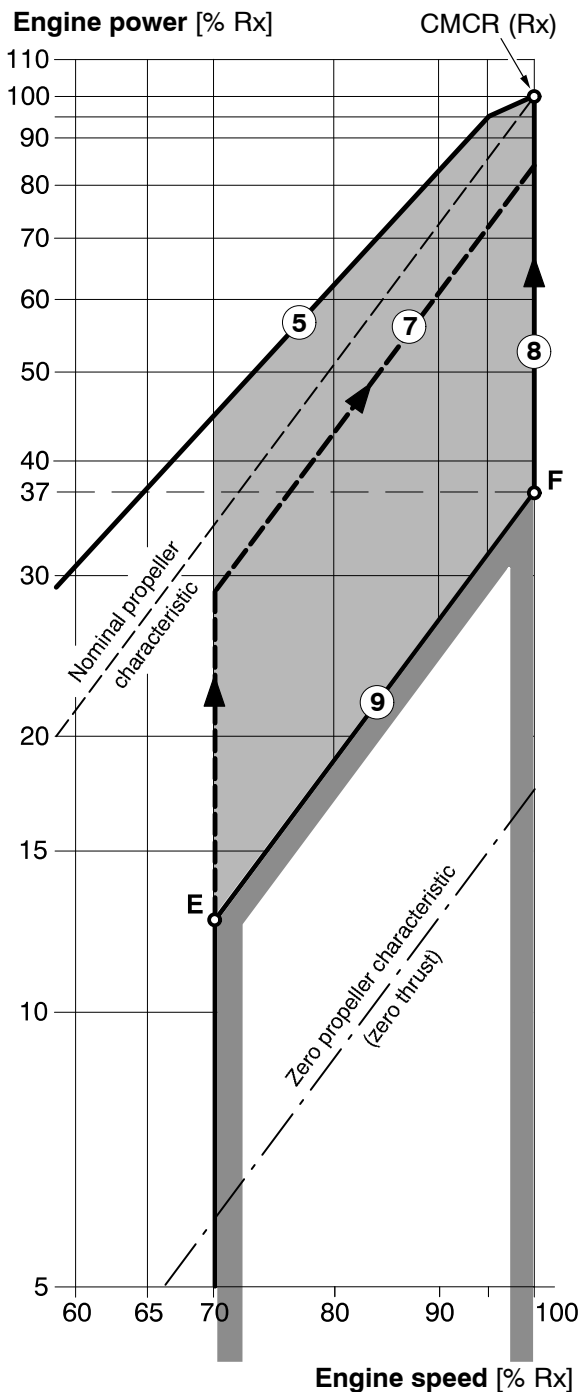

- Line **9** is the bottom load limit between 70% and 100% speed, with such a pitch position that at 100% speed a minimum power of 37 % is reached, point **F**. The formula shown on page 1 is used for this calculation.
- Along line **8** the power increase from 37% (point **F**) to 100% power (CMCR) at 100 % speed is the constant speed mode for shaft generator operation.
- Line **5** is the top load limit and relates to the admissible torque limit.
- The area between 70% and 100% speed and between lines **5** and **9** shows the area within which the engine with CPP must be operated.

Line **7** shows a typical combinator curve for variable speed mode.

Maneuvering at maximum speed with low or zero pitch is not permitted. Thus installations with main engine-driven generators must be equipped with a frequency converter when electrical power is to be supplied (e.g. to thrusters) at constant frequency during manoeuvring. As an alternative, power from auxiliary engines can be used for this purpose.

For test purposes, the engine can be operated at rated speed and low load during a one-time period of 15 minutes on the testbed (e.g. NO_x measurements) and 30 minutes during dock trials (e.g. shaft generator adjustment) in the presence of authorized representatives of the engine builder. More requests must be agreed from WCH.

Engine operation is not permitted in this area

Operate the engine in this area when a CPP is installed

The Relation between Engine and Propeller

3.2 Control system

The CPP control functions are usually part of the engine control system and include the functions that follow:

Combinator mode 1:

Combinator mode for operation without shaft generator. Any combinator curve including a suitable light running margin may be set within the permissible operating area, typically line 7.

Combinator mode 2:

Optional mode used in connection with shaft generators. During manoeuvring, the combinator curve follows the line 9. At sea the engine is operated between point F and 100% power (line 8) at constant speed.

For manual and/or emergency operation, different setpoints for speed and pitch are usually supplied.

An alarm is also usually given in the main engine safety system, or the alarm and monitoring system when the engine operates for more than 3 minutes in the operation area that is not permitted. If the engine operates for more than 5 minutes in the operation area that is not permitted, the engine speed must be decreased to idle speed (less than 70%).

Intentionally blank

General

Engine Numbering and Designations

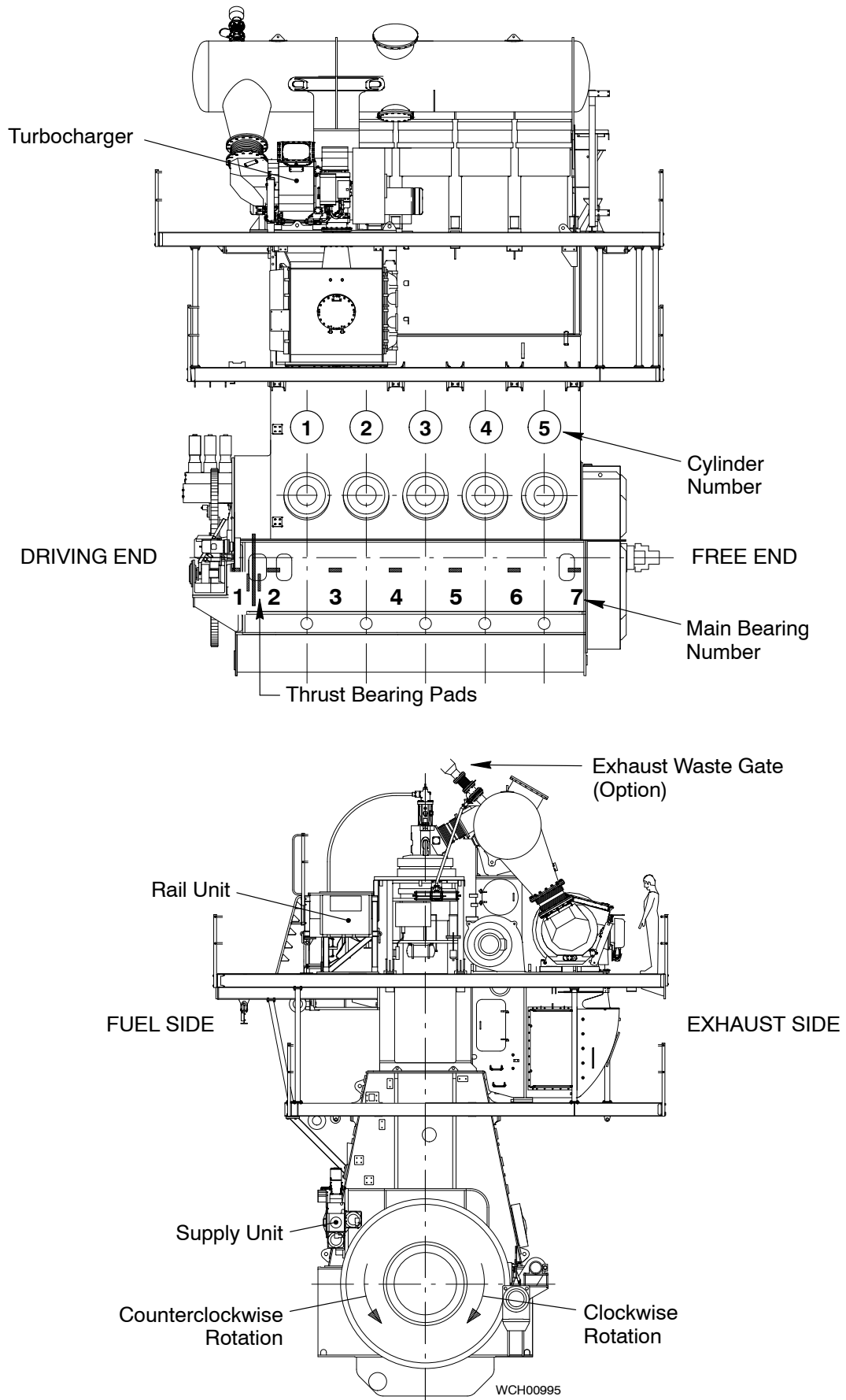

Engine Numbering and Designations

flex Parts:

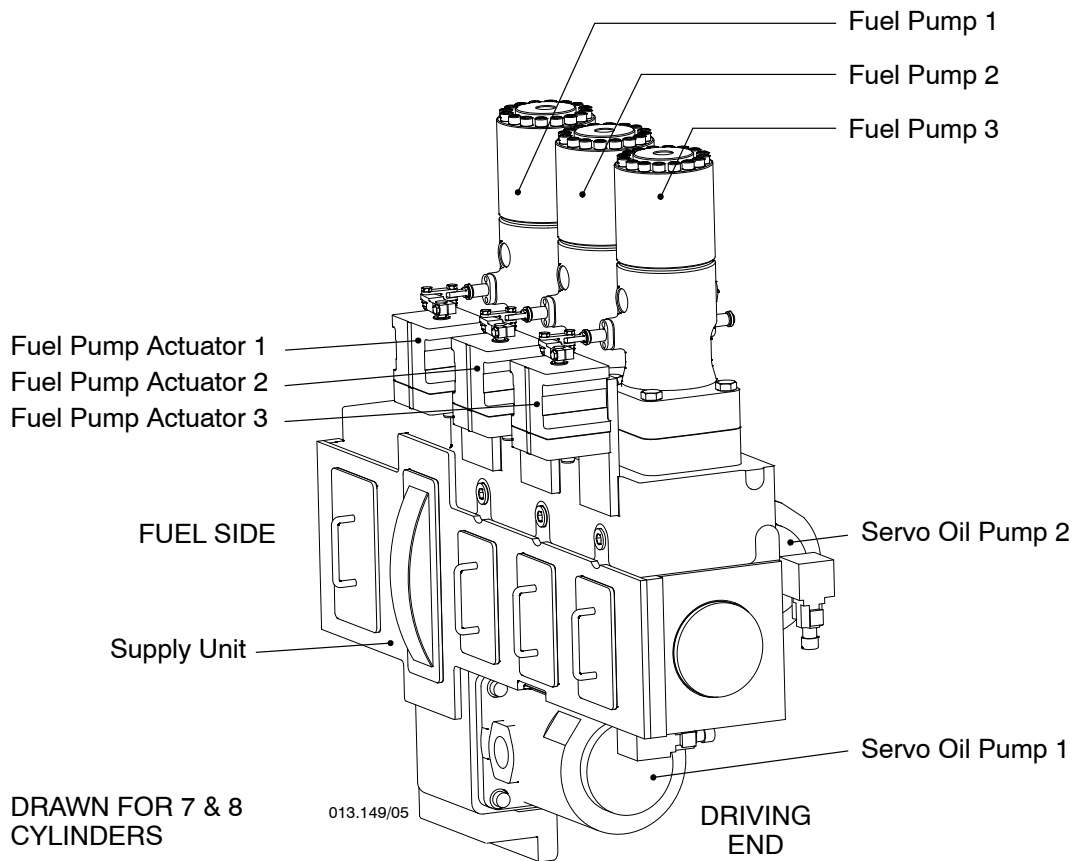

Crank Angle Sensors

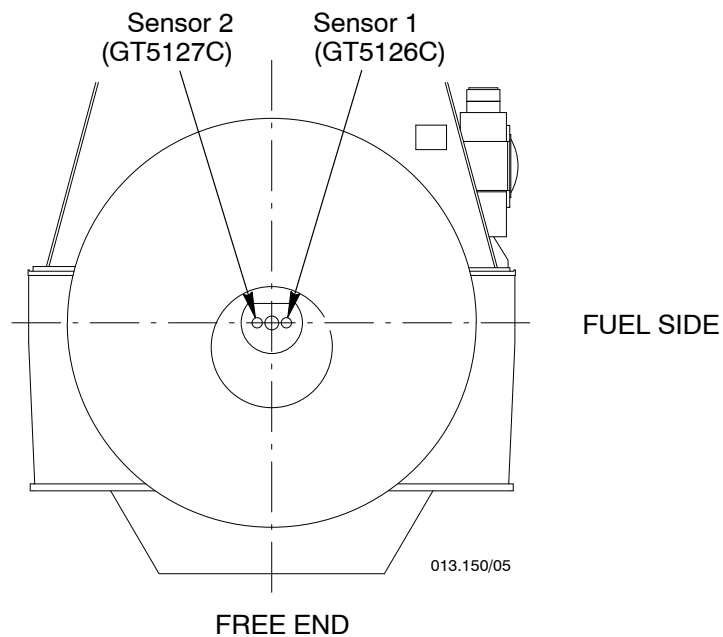

Preparation before Taking into Service

Prepare the Engine before Start after a Short Shut-down (One or More Days)

1. Starting position

For the start position, the engine must be in the condition that follows:

- All components which had an overhaul are correctly assembled and installed. All components which had an overhaul have had tests or checks to make sure that they function correctly.
- All devices, tools and materials are removed from the engine.
- The fuel pump settings and the connections of the actuators to the regulating linkages are correct.



Attention! The venting valves 2.21 and 2.27 in the start air line must be open when the starting air shut-off valve 2.03 is in the manually CLOSED position (see Control Diagram 4003-2).

2. Checks and preparations

- ⇒ Do a check of the fluid levels of all the tanks in the engine systems (and the leakage drain tanks).
- ⇒ Make sure that all the shut-off valves for the cooling water system and lubrication oil system are in the correct position.
- ⇒ Open the air supply from the shipboard system and from the starting air bottles 9.01 to the control air supply **A**.
- ⇒ Open the shut-off valve at connection A1 and set the air spring venting 4.08 to the operation position (see Control Air Supply 4605-1).
- ⇒ Heat the lubricating oil to approximately 35°C (through the separating circuit or the heaters in the oil drain tank).
- ⇒ Heat the cylinder cooling water to min. 60°C.
- ⇒ Set to on the remote control system and the WECS-9520.
- ⇒ In the power supply box E85, set all the circuit breakers to on.
- ⇒ Make sure that the two green LEDs on all FCM-20 modules come on.
- The FCM-20 modules can operate if no red LEDs come on after the countdown process.
- ⇒ Prepare the servo oil system (see 0130-1).
- ⇒ Start the pumps for cylinder cooling water, bearing and crosshead bearing lubricating oil and set the pressures to their usual values (see Operating Data Sheet 0250-1).
- ⇒ Set to on the control box for the automatic filter (see the documentation of the automatic filter manufacturer).
- ⇒ Set to on the main switch of the servo oil service pump.
- ⇒ Prepare the cylinder lubricating system (see 0140-1).
- ⇒ Prepare the fuel oil system (see 0120-1).
- ⇒ Make sure that you correctly release all the air from all systems.
- ⇒ Make sure that there is an air spring supply and make sure that all exhaust valves are closed.
- ⇒ In the remote control, use the parameter Exv. A/M Cmd to manually open and close all exhaust valves 4.01 until all air is released in the hydraulic actuators (see 4002-3 User Parameters and Maintenance Settings, paragraph 1).



Remark: You cannot start the engine if the exhaust valves are not fully closed.

Prepare the Engine before Start after a Short Shut-down (One or More Days)

⇒ Open the indicator valve on all cylinder covers.



Attention: Make sure that no personnel are near the flywheel.

⇒ Use the turning gear to turn the engine a minimum of one full turn to make sure that all the running gears will operate correctly.



Remark: Oil, water or fuel must not come out of the indicator valves.

⇒ If water oil or fuel spray from the indicator valves, do a check of the applicable cylinder liner, cylinder cover, piston or injection valves.

⇒ Set the cylinder lubrication to on.

⇒ Close the indicator valves on all cylinders.

⇒ Make sure that all the clamps lock all the crankcase doors.

⇒ Make sure that the fuel pump regulating linkage moves freely in the spring links.

⇒ Check the pressure in the starting air bottles and open their drains until any condensate has been drained.

⇒ Open the drain and test valve 2.06 to drain possible condensate water.

⇒ Close the drain and test valve 2.06.

⇒ Close the venting valves 2.21 and 2.27.

⇒ Open the main shut-off valves on the starting air bottles 9.01.

⇒ Turn the handwheel 2.10 of the shut-off valve for starting air 2.03 to the position AUTOMAT.

⇒ Open the shut-off valve at connection A2 (see Control Air Supply 4605-1).

⇒ Make sure that the pressure gauges on the instrument panel show starting air pressure and control air pressure.

⇒ Make sure that a pressure indication shows on the pressure gauges for the control air supply.

The different circuits are:

- Air spring air
- Control air.



Remark: The air supply from the control air board supply and the back-up supply from the starting air system flow through the pressure reducing valve 19HA.

For the necessary pressures, see the Operating Data Sheet 0250-1.

⇒ Set the switches on the control panels for the auxiliary blowers to AUTOMAT.

⇒ Set to off the servo oil service pump.

⇒ Disengage the turning gear and lock the lever.

⇒ Open the test valve 2.06 of the shut-off valve for starting air 2.03 for a short time. Make sure that you can hear the valve open.

⇒ Close the test valve 2.06.



Attention: Make sure that no personnel are near the flywheel.

⇒ Push the SLOW TURNING button in WECS-9520 manual control panel on the local control panel (4618-1, Local Control Panel, paragraph 2.1). The engine will slowly turn one time (see also Slow Turning 0220-1).

⇒ Make sure that at the location where you want to start the engine, the related WECS-9520 control panel has control (e.g. the bridge, control room or local control panel).

⇒ Make sure that no personnel are near the flywheel.

⇒ Tell personnel on the bridge that the engine is prepared for operation.

Preparation before Taking into Service

Prepare the Fuel Oil System for Operation

1. For diesel oil operation

See 0720-1 'Layout of the fuel oil system', Fig. 'B'.

- ⇒ Set the three-way valve 4 in the suction line of the low pressure feed pump 7 to let diesel oil flow from the daily tank 3 to the pump and to the mixing unit 8.
- ⇒ Make sure that the shut-off valves upstream and downstream of the engine are open.
- ⇒ Start the pumps 7 and 10.
- ⇒ Drain the daily tanks and the mixing unit.
- ⇒ Use the pressure regulating valve 5 to set the pressure in the fuel system.



Remark: During operation with diesel oil (and low fuel temperature) a small over-pressure is sufficient. If a change-over to heavy fuel oil (HFO) is necessary, the setting of usual pressure is recommended from the start.

- ⇒ Use the pressure retaining valve 17 to set the fuel pressure at the fuel pump inlet (pressure difference upstream / downstream of the pressure retaining valve, see the Operating Data Sheet 0250-1).

2. For heavy fuel oil operation

See 0720-1 'Layout of the fuel oil system'.



Remark: The fuel system is not ready for service until the HFO upstream of the fuel pumps is at the necessary temperature (see the Viscosity-Temperature Diagram 0710-1).

The high pressure circuit on the engine must be heated for between four to six hours after a long shut-down period (more than 24 hours).



Attention! Do not start the engine with HFO before the high pressure circuit is heated.

- ⇒ Set to on the heating for the HFO daily tank 2, mixing unit 8, end-heater 11 and filter 12.
- ⇒ Set to on the heating for the fuel system on the engine (fuel rail 11 (3.05), fuel rising pipes 10 and 10a (3.29) and the fuel leakage system (see 8019-1).
- ⇒ Do a check of the steam pipes to make sure they are tight. If leaks are found, they must be repaired before the first commissioning or after maintenance on the fuel system.
- ⇒ Set the three-way valve 4 in the suction line of the low pressure feed pump 7 so that HFO flows from the daily tank 2 to the pump 7 and the mixing unit 8.
- ⇒ Drain the settling tank, daily tanks and mixing unit 8.
- ⇒ Make sure that the shut-off valves upstream and downstream of the engine are open.
- ⇒ Start the pumps 7 and 10.
- ⇒ Heat the HFO. This is necessary to get the HFO to the necessary viscosity (see Changing Over from Diesel Oil to Heavy Fuel Oil 0270-1).
- ⇒ Use the pressure regulating valve 5 to set the pressure in the fuel system.
- ⇒ Use the pressure retaining valve 17 to set the fuel pressure at the fuel pump inlet (pressure difference upstream / downstream of the pressure retaining valve, see the Operating Data Sheet 0250-1).

Prepare the Fuel Oil System for Operation

3. Vent and leak test of fuel oil system on the engine

See 0720-1 'Layout of the fuel oil system' Fig. 'B' and Fuel Oil System 8019-1, Fig. 'A'.



Remark: The numbers in the parentheses () below refer to items in 0720-1, 'Layout of fuel oil system' Fig. 'B'. The numbers in the square brackets [] refer to items in 4003-2, Control Diagrams. Numbers that do not have parenthesis or square brackets refer to items in 8019-1, Fig. 'A'.

Procedure:

The fuel oil system can be vented manually as follows:

- The engine control system WECS-9520 is set to on.
- ⇒ Start the low pressure feed pump (7) and the booster pump (10).
- When the booster pump (10) starts, fuel flows through the fuel pumps 3 [3.14], then flows through the fuel rising pipes 10 and 10a [3.29] into the fuel rail 11 [3.05].
- ⇒ Use the hand lever on the fuel shut-down pilot valve 24 [3.08] to bleed the fuel rail through the fuel pressure control valve 23 [3.06].

Leak test:

To do a leak test, use the servo oil service pump [4.88] to keep the high pressure circuit pressurized.

- ⇒ Remove the plug 35 [3.39] and the plug on stop valve [3.40].
- ⇒ Connect the tool 94583 (pipe) between the fuel rail 11 [3.05] and the servo oil rail [4.11] and open the stop valve [3.40].
- ⇒ Set to on bearing oil pump and servo oil service pump [4.88].
- The pressure (70 bar to 100 bar) can be seen on pressure gauge of the servo oil service pump.
- ⇒ Do the leak test.
- ⇒ Close the stop valve [3.40].
- ⇒ Remove the tool 94583 (pipe).
- ⇒ Apply Never-Seez NSBT-8 to the thread and seating surface of the plug 35 [3.39].
- ⇒ Torque the plug 35 [3.39] to 300 Nm.
- ⇒ Install and tighten the plug on the stop valve [3.40].

Preparation before Taking into Service

Prepare the Servo Oil System

1. Procedure

For more data, see [8016-1](#) 'Servo oil system', paragraph 4.

CHECK

Do the checks that follow:

- ⇒ Make sure that the stop valve 14 (4.37) upstream of the automatic filter 1 (4.20) is open.
- ⇒ Make sure that the stop valve 18 (3.40) is closed.
- ⇒ Make sure that at free end of the servo oil rail 7 (4.11), the plug is installed.

Intentionally blank

Preparation before Taking into Service

Prepare the Cylinder Lubricating System

1. Procedure

For more data, see Cylinder Lubrication [7218-1](#) Fig. 'A', Fig. 'B', Fig. 'C', Fig. 'D' and Fig. 'I'.

- The WECS-9520 engine and remote control system are set to on.
- The servo oil service pump 4.88 operates.

CHECK

Do the checks that follow:

⇒ Make sure that:

- On all ALM-20 modules the green LEDs come on.
- The stop valve 5 (4.30-5) is open (see Fig. 'B').
- The ball valve 5 downstream of the lubricating oil filter 1 (8.17) is open (see Fig. 'C').
- The lubricating oil filter 1 (8.17) and the measurement tube 4 (8.19) has no air (see Fig. 'C').
- The ball valve 10 downstream of the measurement tube 4 (8.19) is open (see Fig. 'C').
- The shut-off valve 6 (to the servo oil inlet of the lubricating pumps 8.06) is open (see Fig. 'D').
- The stop valve 7 (in the lubricating oil pipes to the exhaust valve) is closed (see Fig. 'I').



Remark: The stop valve 7 must be open during the first commissioning of the engine until the end of the sea trial, or after an exhaust valve overhaul (see 7218-1 'Additional lubrication of exhaust valve spindle').

- There is no air in the lubricating pumps 8.06 (servo and lubricating oil).
- There is no air in the lubricating pipes to the lubricating quills.



Remark: You must only do the air removal procedure:

- Before first commissioning
- After maintenance
- After a long shut-down period
- When there are problems during operation (pressure, feed rate).

Intentionally blank

Operation during Usual Conditions

Summary

1. General

The data that follow are about engine operation during usual conditions e.g all cylinders operate correctly:

[0210-1](#) Safety Precautions and Warnings

[0220-1](#) Slow Turning

[0230-1](#) Starting

[0240-1](#) Usual Operation.

During maneuvering, it is possible to operate the engine from the control room, the bridge or the local maneuvering stand.

For operation during unusual conditions, see [0500-1](#).

Operation includes all maneuvers from the first start at cast off until the last maneuver when the vessel is moored.

The engine is designed to operate with heavy fuel oil (HFO) from pier-to-pier, i.e. without a change-over to diesel oil.

When the engine is at a standstill, the fuel flows through the fuel pumps if the booster pump operates.

The necessary conditions of HFO before operation are as follows:

- The HFO is correctly treated.
- The HFO is kept at the correct temperature during the full in-service period, which includes manoeuvring and stand-by.

Intentionally blank

Operation during Usual Conditions

Safety Precautions and Warnings (General Information)

Overview

1.	General	1/4
2.	Warnings	1/4
3.	Lighting	1/4
4.	Clean areas	1/4
5.	Fire	2/4
6.	Tools	2/4
7.	Spare parts	2/4
8.	Crankcase doors – Open	2/4
9.	Temperature	3/4
10.	Crankcase, cylinder, exhaust pipes and receiver	3/4
11.	Carbon Dioxide (CO ₂) gas	3/4
12.	Crankcase doors – Close	3/4
13.	Turning gear	4/4
14.	Instruments	4/4
15.	Frost hazard	4/4

1. General

A correctly maintained engine gives problem-free and safe operation. Use the data given below as a guide to the maintenance personnel.

For more data about the general maintenance procedures, see the Maintenance Manual 0011-1 and 0012-1.

2. Warnings



Injury Hazard: When you remove valves from the cylinder cover, do not let oil or fuel fall on to the hot piston. This can cause an explosion.



Injury Hazard: Be careful when you disassemble the engine without the correct tools and/or the necessary precautions. Compressed springs can suddenly expand and cause injury.



Injury Hazard: When you open valves and shut-off devices, hot fluids or gases can be released. To prevent injury, always open slowly the valves and shut-off devices and look at the direction the medium is released.

3. Lighting

There must be good permanent lighting. Also, hand lamps must be available at different locations in the engine room.

4. Clean areas



Attention! Do not use water or any cleaning fluid to clean the WECS electronic control boxes on the rail unit. Damage can occur if fluids go into these control boxes.

Always keep the engine as clean as possible.

Keep the WECS electronic control boxes on the rail unit clean and dry.

You must repair all leaks as soon as possible.

Dust, sand and chemical vapors must not go into the engine room.

Safety Precautions and Warnings (General Information)

5. Fire



Injury Hazard: Be careful when you use paints and solvents in the engine room. These materials are flammable.



Injury Hazard: Insulation material that is soaked with oil or fuel is flammable and must be replaced.

Make sure that you know the fire fighting instructions.

Before you do welding work or work that causes sparks, make sure that there are no explosive fluids in the work area.

Make sure that fire fighting equipment is immediately available if you must do work that causes sparks in the engine room.

Some components e.g. the turbocharger silencer and WECS electronic control boxes, must be protected with an applicable cover.

Keep covers and casings closed until the engine has cooled to decrease the risk of fire or explosions.

The engine room and the area below the floor plates must be kept clean. This will help prevent a fire in the engine room and in different areas.

Make sure that no fire extinguisher gases can be automatically released when personnel are in the engine room.

Make sure that the emergency exits are clearly marked.

6. Tools

Put hand-tools in locations where you can easily get access to them. Put special tools and devices in positions in the engine room near the area where you use them.

All tools must be prevented from unwanted movement and must have protection from corrosion.

7. Spare parts

Keep large spare parts as near as possible to the position where they will be installed and near the engine room crane.

You must prevent the unwanted movement of large spare parts.

All the spare parts must have corrosion protection. The corrosion protection agent must be easy to remove. Examine the corrosion protection agent at regular intervals and replace if necessary.

The spare parts must also have protection from mechanical damage.

Spare parts that are removed from the store must be replaced as soon as possible.

8. Crankcase doors – Open



Danger: If you think that parts of the running gear or bearings have become too hot, it is possible that the engine must be shut down. Before you open the crankcase doors, you must wait for a minimum of 20 minutes. This will prevent an explosion.



Injury Hazard! Be careful when you touch hot parts with your hands. This can cause injury.

Safety Precautions and Warnings (General Information)

9. Temperature



Danger: If you think that parts of the running gear or bearings have become too hot, it is possible that the engine must be shut down. Before you open the crankcase doors, you must wait for a minimum of 20 minutes. This will prevent an explosion.



Injury Hazard! Be careful when you touch hot parts with your hands. This can cause injury.

When commissioning an engine after an overhaul of its running gear, do a temperature check to find unusually high temperatures in areas of the engine. Do this temperature check after 10 minutes of engine operation.

Do the temperature check again after approximately one hour of engine operation.

After a short period of operation at full load, do the temperature check again.

10. Crankcase, cylinder, exhaust pipes and scavenge air receiver

Before you go into the spaces of the crankcase, cylinder, exhaust pipes and scavenge air receiver, make sure that:

- Starting air to the engine is blocked and venting valves 2.21 and 2.27 are open (see Control Diagram 4003-2).
- The turning gear is engaged (see also Maintenance Manual 0011-1 Precautionary measures before beginning of maintenance work).



Attention! Other ships in the water cause currents, which will make the propeller and the engine turn. The engine and propeller cannot turn when the turning gear is engaged.

11. Carbon Dioxide (CO₂) gas



Injury Hazard! Where CO₂ is used to extinguish a fire in the engine, there is a risk of suffocation. Make sure that all related spaces have good airflow to remove all CO₂ gas before you go into the engine.

12. Crankcase doors – Close

Make sure that all crankcase doors are closed and locked before you operate the engine. This is also applicable to short periods of engine operation e.g. running-in, after the replacement of bearings, etc.

Safety Precautions and Warnings (General Information)

13. Turning gear

When the turning gear is used, the indicator valves in the cylinder covers must be open. If the air spring system is not pressurized, the indicator valves can stay closed.

The lubricating oil pump must operate if possible, but the oil pressure cannot fully increase when the exhaust valves are open.



Injury Hazard! Make sure that no personnel and components are in the danger areas (crankcase, piston underside, propeller shaft, etc). The propeller coupling also turns.



Remark: If the engine is stopped for overhaul, you must engage the turning gear to prevent engine movement.

If the engine is ready for maneuvering, the turning gear must not be engaged.

Before you start the engine, make sure that the turning gear is disengaged and the lever is locked. It is possible that the blocking valve 2.13 (see [4003-2 Control Diagram](#)) can prevent engine start.

14. Instruments

Calibrate the instruments (and gages) at regular intervals before you use them.

15. Frost hazard

If the temperature decreases below 0°C and the engine is not in service, it is possible that water in the engine, pumps, coolers and pipe systems will freeze. To prevent this, drain the systems, increase the temperature in the engine room or use an antifreeze (see [0760-1 Cooling Water / Cooling Water Treatment](#), paragraph 5).

Operation under Usual Conditions

Slow Turning

1. General

To make sure that the running gear turns freely, we recommend (as long as the classification society did not make more primary specifications) to turn the crankshaft a minimum of one full turn before start-up. This does not apply if the engine was at standstill during a maneuvering period.

2. Turning gear

The turning gear is used to turn the crankshaft (approximately one turn in 10 minutes). An arrow next to the flywheel shows the direction and distance that the crankshaft has turned.

3. SLOW TURNING with starting air

A controlled quantity of starting air is released to turn the running gear at approximately 5 rpm to 10 rpm.

The WECS-9520 has the command SLOW TURNING for this operation.

The active control stand is used to start the SLOW TURNING operation:

- From the remote control
- At the ECR manual control panel in the control room
- At the local control panel (see [4618-1](#) 'WECS-9520 manual control panel').

3.1 Conditions



Remark: The numbers e.g. 2.03 refer to items in the Control Diagram [4003-2](#).

Before you start the SLOW TURNING operation, make sure that:

- The turning gear is disengaged
- WECS-9520 is set to on
- The oil pumps operate (bearing and crosshead oil)
- The related control stand has control
- The indicator valves are closed
- The handwheel 2.10 on the shut-off valve for starting air 2.03 is in the position AUTOMAT
- The shut-off valves on the starting air bottles are open
- The cylinder lubrication is set to on.

3.2 Function

The function below is almost the same as the engine start function.

- The control valve 2.05 opens the shut-off valve for starting air 2.03 and starting air flows to the starting air valves 2.07 in the cylinder covers.
- The FCM-20 modules control the 5/2-way solenoid valves upstream of the starting valves. The starting valves open and close for short periods only.
- You can use the remote control to change the timing of the starting valves (open / close) to get the best slow turning speed.

Intentionally blank

Operation under Usual Conditions

Starting

1. General

Before you start the engine (also, before trials and using starting air to turn the engine) see:

- Preparation before Taking into Service [0110-1](#)
- Prepare the Fuel Oil System for Operation [0120-1](#)
- Prepare the Servo and Control Oil System [0130-1](#)
- Prepare the Cylinder Lubricating System [0140-1](#)

You can start the engine from the locations that follow:

- The bridge or control room with remote control
- At the backup control box in the control room
- At the local control panel on the engine.

2. Engine start – control stand in control room

Prepare the engine as follows:

- ⇒ At WECS-9520 manual control panel (see [4618-1](#)), push the button REMOTE AUTOM. CONTROL (Remote Control) for mode transfer to the remote control.
- ⇒ At the control room console, push the button REMOTE AUTOM. CONTROL (Remote Control) to get control.

For more procedures to start the engine with the remote control, see the documentation of the remote control manufacturer. If you move the telegraph from STOP to a different position, a start signal is released automatically.

3. Engine start – local control panel

You use this mode if e.g. the electronic speed control system or the remote control becomes defective.



Attention! The operator must not leave the local maneuvering stand. The operator must regularly monitor the speed indication to immediately adjust the fuel supply if the speed changes.

Prepare the engine as follows:

- ⇒ At the WECS-9520 manual control panel, push the button LOCAL MANUAL CONTROL (Local Control) for mode transfer to local manual control.

Engine start

- ⇒ Push the button AUX. BLOWER PRESEL.
- ⇒ Push the button FUEL CONTROL MODE.
- ⇒ Turn the rotary knob to set the fuel injection quantity to approximately 15%.
- ⇒ Push the button START AHEAD or START ASTERN until the engine operates.
- ⇒ Slowly turn rotary knob to adjust the fuel injection quantity until the engine operates at the necessary speed. You can see the related value on the display and speed indicator.
- ⇒ Read the instructions for speed/power increase (see Maneuvering [0260-1](#)) and monitor the data (see Operating Data Sheet [0250-1](#)).

You can also do the engine start procedure above from the ECR manual control panel.



Remark: You can use the buttons and rotary button only at the related active control stand (see [4618-1](#) 'WECS-9520 manual control panel').

Intentionally blank

Operation during Usual Conditions

Usual Operation

1. General

To get the best performance, operate the engine at constant power. You must only change the engine load and / or speed slowly, unless there are unusual conditions.

2. Checks and precautions

CHECK

During usual operation, you must do regular checks and use precautions. This lets you operate the engine without problems. The most important of these regular checks and precautions are given below:

- Regular checks of pressures and temperatures. You must obey the limits (see Operating Data Sheet [0250-1](#)).
 - You must compare the values of the instruments with those given in the acceptance records and include the engine speed and power values. This gives a good indication of engine performance. If there are differences in the values, these must be identified. If there is no risk to the engine, replace instruments that are possibly defective. Feel the pipes to compare temperatures.
- ⇒ Do a check of the values that follow:
- Fuel injection quantity
 - Fuel rail pressure
 - Servo oil rail pressure
 - Engine speed
 - Turbocharger speed
 - Scavenge air pressure
 - Exhaust gas temperature upstream of the turbine.

Other important data is the value of the daily fuel consumption and the lower calorific value.

- ⇒ Do a check to make sure that all shut-off valves in the cooling and lubricating system are in the correct position.
- The shut-off valves for the cooling inlets and outlets on the engine must always be fully open during operation. These shut-off valves are used only to isolate cylinders from the cooling water system during overhauls.
 - When unusually high or low temperatures are found at a water outlet, the temperature must be gradually adjusted to the usual value. Sudden temperature changes can cause damage (see also Cylinder Liner [2124-1](#) and Cooling Water System [8017-1](#)).
 - The maximum permitted exhaust temperature at the turbine inlet must not be more than the limit given in the Operating Data Sheet [0250-1](#). Compare the exhaust gas temperature indications at the cylinder outlet with the related values in the acceptance records. If larger differences between the cylinders are shown, you must find the cause.
 - Look at the colors of the exhaust gases from the funnel. No dark smoke must come out.
 - Keep the correct scavenge air temperature downstream of the air cooler with the usual water flow (see Operating Data Sheet [0250-1](#)). A higher scavenge air temperature will give an unsatisfactory quantity of charge air in the cylinder. This will cause a higher fuel consumption and higher exhaust gas temperatures.
 - Do a check of the scavenge air pressure decrease through the air cooler. Too much resistance will cause to a decrease of air to the engine.

Usual Operation

- The fuel must be carefully cleaned before use. See the recommendations in [0720-1 Fuel Treatment, Fuel Oil System](#) and the documentation of the separator manufacturer.
- ⇒ Open the drain valves of all fuel tanks and fuel filters regularly for short periods to drain possible sludge or water.
- ⇒ Keep the fuel pressure correct downstream of the low pressure feed pump and the inlet of the mixing unit (see the Operating Data Sheet [0250-1](#) and [0720-1](#), paragraph 4 Layout of the fuel oil system).
- ⇒ Use the pressure retaining valve in the fuel return pipe to adjust the pressure at the fuel pump inlet. The fuel will flow in the low pressure circuit of the engine at the usual supply capacity of the booster pump.
- The heavy fuel oil must be sufficiently heated to make sure that its viscosity upstream of the inlet to the fuel pumps is in the limits given in [0710-1 Viscosity-Temperature Diagram](#), paragraph 3.1).
- Do regular checks of the cylinder lubricating oil quantity that is used. Continuous service will give the best cylinder lubricating oil quantity. Do not lubricate the cylinders too much. For the usual quantity used, and how to calculate it, see [Measurement of the Cylinder Lubricating Oil Consumption 7218-2](#).
- The cooling water pumps must operate at their usual flow capacity i.e. the supply head is related to the given system layout. The result of the flow rate and temperature difference between the inlet and outlet will approximately relate to the values given in the Operating Data Sheet [0250-1](#). If the temperature difference is too much, repair or replace the related pump as soon as possible.
- To adjust the correct supply head of the cylinder cooling water pump, the supply rate must be throttled in the engine outlet manifold. There must always be positive pressure at the suction side of the pump to prevent air flow through the stuffing box.
- Keep the vents at the top of the cooling water spaces constantly open to release the air.
- Do a check of the level in all water and oil tanks, and all the drainage tanks of the leakage pipes. Look for unusual changes.
- Look at the cooling water. If there is contamination or oil in the cooling water, the cause must be found and the defect repaired.
- Each week, open the butterfly valves 18 and 18a for a short period to flush out possible dirt particles. Regularly examine the sight glasses 20 and 20a of the condensate collectors to do a check of the water flow (see [Drainage System and Wash-water Piping System 8345-1](#), Fig. 'A').
- If there is a pressure decrease, do a check of the oil filters. Clean the oil filters if necessary.
- Do regular checks of the differential pressure through the automatic filter and the flush process.
- You must monitor for a period, bearings that are replaced or bearings that are installed after an overhaul. You must obey the precautions to prevent crankcase explosions (see [0460-1](#)).
- Always keep the covers of the rail unit closed when the engine operates.

Usual Operation

- When you listen to the engine, unusual noises will show that there is a possible defect.
- Hand-drawn diagrams give data about the combustion process and pressures in the cylinder (see Indicator Diagrams [0420-1](#)).

When the quality of the fuel used changes (diesel oil, heavy fuel oil from different bunkerings), the maximum pressure in the cylinder at service power must be found as soon as possible. You must compare this pressure to the pressure measured during the related shop trial (speed, power).

In case considerable firing pressure differences are detected, i.e. too high or too low, they must be adjusted by the electronic FQS in the remote control (see [4002-3](#) 'User parameters').

- Put the lubricating oil through a centrifuge. Get samples at regular intervals and compare these samples with the values given in Lubricating Oils [0750-1](#).
- Do a check of the dirty oil drain pipes from the piston underside to make sure that there are no blockages. Use your hand to touch each drain pipe to feel for a temperature difference. A pipe is blocked when there is a temperature difference along its length. You must clear all blockages as soon as possible.
- Examine regularly the lubricating and fuel oil systems for leaks (see [8016-1](#) Servo oil leakage system and [8019-1](#) Fuel leakage system). To find leakages in the rail unit, open the related hinged covers and casings. You must repair leaks as soon as possible.

Intentionally blank

Operating Data Sheet

Pressure and Temperature Ranges at Continuous Service Power MCR

Medium	System	Location of measurement	Gage pressure [bar]		Temperature [°C]		
			Min.	Max.	Min.	Max.	Diff.
Fresh water	Cylinder cooling	Inlet	3.0	5.0	65	–	max.
		Outlet each cylinder	–	–	80	90	15
	SAC, high temperature circuit HT (two-stage scavenge air cooler)	Inlet	3.0	5.0	65	80	–
		Outlet	–	–	–	120	–
	SAC, low temperature circuit LT (two-stage scavenge air cooler)	Inlet	2.0	4.0	25	36	See 3)
		Outlet	–	–	–	–	–
SAC, low temperature circuit LT	Inlet	2.0	4.0	25	36	See 3)	
	Outlet	–	–	–	57	–	
Lubricating oil (high pressure)	Crosshead bearing	Inlet	10	12	40	50	–
Lubricating oil (low pressure)	Servo oil	Servo oil pump inlet	2.6	5.5	–	–	–
	Main bearing	Inlet	3.6	5.0	40	50	–
	Piston cooling	Inlet	3.6	5.0	40	50	max.
		Outlet	–	–	–	80	30
	Thrust bearing	Outlet	–	–	–	60	–
	Torsional vibration damper (steel spring damper)	Supply	3.6	5.0	–	–	–
		Damper inlet	2.8 ²⁾	5.0 ⁴⁾	–	–	–
	Axial vibration damper (chamber pressure)	Supply	3.6	5.0	–	–	–
		Monitoring	1.7	–	–	–	–
	Turbocharger bearing (ABB, TPL and A100-L type) (with internal oil supply)	Inlet	1.0	2.5	–	–	–
		Housing outlet	–	–	–	110	–
	Turbocharger bearing (ABB TPL) (with internal oil supply)	Inlet	1.3	2.5	–	80	–
		Housing outlet	–	–	–	120	–
	Turbocharger bearing (ABB A100-L) (with external oil supply)	Inlet	1.3	2.5	–	85	–
Housing outlet		–	–	–	130	–	
Turbocharger bearing (MHI, MET type)	Inlet	0.7	1.5	–	–	–	
	Housing outlet	–	–	–	85	–	
Fuel oil	Supply unit (fuel pump)	Inlet	7.0 ¹⁾	10 ²⁾	–	150	–
	Downstream of pressure retaining valve (fuel pump)	Return	3	5	–	–	–
Scavenge air	Cooler	After each cooler	–	–	25	60	–
	Intake from engine room (pressure decrease)	Air filter / silencer	max. 10 mbar		–	–	–
	Intake from outboard (pressure decrease)	Ducting and filter	max. 20 mbar		–	–	–
	Scavenge air cooler (SAC) (pressure decrease)	New SAC	max. 30 mbar		–	–	–
		Dirty SAC	max. 50 mbar		–	–	–
Air	Starting air	Engine inlet	12	25 / 30	–	–	–
	Control air	Engine inlet	6.0	7.5	–	–	–
			normal 6.5	–	–	–	
	Air spring of exhaust valve	Main distributor	6.0	7.5	–	–	–
normal 6.5			–	–	–		
Exhaust gas	Receiver	Downstream of cylinder	–	–	–	515	Tolerance ±50
		Turbocharger inlet	–	–	–	515	–
	Manifold after turbocharger	New	max. 30 mbar		–	–	–
		Dirty	max. 50 mbar		–	–	–

Pressure and Temperature Ranges at Continuous Service Power MCR

Notes to pressure and temperature ranges:

- For the slow-down and shut-down alarm limits, see group [0250-2](#).
 - Pressure measured approximately 4 m above crankshaft centerline.
- 1) At 100% engine load.
 - 2) At stand-by condition. During commissioning of the fuel oil system, the fuel pressure at the inlet of the fuel pumps is adjusted to 10 bar.
 - 3) The water flow must be within the specified limits (scavenge air cooler specification).
 - 4) The value can be different. For the applicable setting value, refer to the specification of the damper manufacturer.

Operating Data Sheet

Alarms and Safeguards at Continuous Service Power

Medium Performance	Physical unit	Location	Signal No. 1)	Function 2)	Type of signal 3)	Setting value [bar / °C]	Function time delay [sec]
Cylinder cooling water	Pressure	Engine inlet	PT1101A	ALM	L	3 bar	0
				SLD	L	2.8 bar	60
			PS1101S	SHD	L	2.5 bar	60
	Temperature	Engine inlet	TE1111A	ALM	L	65°C	0
		Outlet each cylinder	TE1121A -27A	ALM	H	90°C	0
				SLD	H	95°C	60
Scavenge air cooling water HT circuit Two-stage SAC 4) Fresh water	Pressure	Cooler inlet	PT1301A	ALM	L	3.0 bar	0
				SLD	L	2.5 bar	60
	Temperature	Cooler outlet	TE1331A -32A	ALM	H	120°C	0
				SLD	H	125°C	60
	Pressure	Cooler inlet	PT1361A	ALM	L	2 bar	0
			TE1371A -72A	ALM	L	25°C	0
TE1381A -82A			ALM	H	60°C	0	
Temperature	Cooler inlet	TE1371A -72A	ALM	L	25°C	0	
		Cooler outlet	TE1381A -82A	ALM	H	70°C 16)	0
				ALM	H	70°C 16)	0
Lubricating oil Bearing and piston cooling (low pressure supply)	Pressure	Engine inlet	PT2001A	ALM	L	3.6 bar	0
				SLD	L	3.4 bar	60
			PS2002S	SHD	LL	2.9 bar	10
	Temperature	Engine inlet	TE2011A	ALM	H	50°C	0
				SLD	H	55°C	60
		Outlet	TE2102A -07A	ALM	H	65°C	0
Crosshead bearing oil (high pressure supply)	Pressure	Engine inlet	PT2021A	ALM	L	10 bar	0
				SLD	L	9 bar	60
	Temperature	Outlet	TE2301A -07A	ALM	H	65°C	0
				SLD	H	70°C	60
	Pressure	Lubricating pump Inlet Free End	PT2041A	ALM	L	40 bar	3
				ALM	H	70 bar	3
PT2046A			ALM	H	10 bar	0	
Servo oil (for cylinder lubrication)	Pressure	Lubricating pump Inlet Free End	PT2051A	ALM	L	2.6 bar	0
				ALM	F	-	0
	Failure	Automatic filter	XS2053A	ALM	F	-	0
Servo oil	Pressure	Servo oil pump inlet	PT2051A	ALM	L	2.6 bar	0
				ALM	L	no flow	0
	Flow	Servo oil pump	FS2061A -62A	ALM	L	no flow	0
Oil leakage monitoring	Level	Supply unit 7)	LS2055A	ALM	H	max. 17)	0
				ALM	H	max. 17)	0
Thrust bearing oil	Temperature	Thrust bearing outlet	TE2101A	ALM	H	65°C	0
				SLD	H	70°C	60
			TE2121A	ALM	H	65°C	0
				SLD	H	70°C	60
			TS2121S	SHD	H	85°C	60
				SHD	H	85°C	60
Oil mist	Concentration	Crankcase	AS2401A	ALM	H	- 18)	0
			AS2401S	SLD	H	- 19)	60
	Failure	Detection unit	XS2411A	ALM	F	- 20)	0
				ALM	F	- 20)	0
Piston cooling oil	Temperature	Outlet each cylinder	TE2501A -07A	ALM	H	80°C	0
				SLD	H	85°C	60
	Diff. pressure	Inlet each cylinder	PS2541S -47S	SHD	H	0.4 bar	15
				SHD	L	no flow	15
	Flow	Inlet each cylinder	FS2521S -27S	SHD	L	no flow	15
			TE2201A -07A	SLD	H	70°C	60

Alarms and Safeguards at Continuous Service Power

Medium Performance	Physical unit	Location	Signal No. 1)	Function 2)	Type of signal 3)	Setting value [bar / °C]	Function time delay [sec]	
Crank bearing oil	Temperature	Outlet	TE2201A -07A	ALM	H	65°C	0	
				SLD	H	70°C	60	
Turbocharger oil (ABB, TPL and A100-L type)	Pressure	Inlet	PT2611A -12A	ALM	L	1 bar	0	
				SLD	L	0.8 bar	60	
				PS2611S -12S	SHD	L	0.6 bar	5
	Temperature	Housing outlet	TE2601A -02A	ALM	H	110°C	0	
				SLD	H	120°C	60	
	Pressure (with external oil supply)	Inlet	PT2611A -12A	ALM	L	1.3 bar	0	
				SLD	L	1.1 bar	60	
	Temperature	Housing outlet (TPL type)	TE2601A -02A	ALM	H	110°C	0	
				SLD	H	120°C	60	
	Additional requirement with external oil supply (TPL type)	Temperature	Housing outlet A100-L type)	TE2601 -02A	ALM	H	110°C	0
					SLD	H	120°C	60
		Inlet	TE2621A	ALM	H	80°C	0	
				SLD	H	85°C	60	
	Additional requirement with external oil supply (A100-L type)	Inlet	TE2621A	ALM	H	85°C	0	
SLD				H	90°C	60		
Turbocharger oil (MHI, MET type)	Pressure	Inlet	PT2611A -12A	ALM	L	0.7 bar	5	
				SLD	L	0.6 bar	60	
				PS2611S -12S	SHD	L	0.4 bar	5
	Temperature	Housing outlet	TE2601A -02A	ALM	H	85°C	0	
				SLD	H	90°C	60	
				Inlet	TE2621A	ALM	H	60°C
SLD	H	65°C	60					
Additional requirement with external oil supply								
Torsional vibration damper oil (steel spring damper)	Pressure	Damper inlet	PT2711A	ALM	L	2.2 bar ²³⁾	0	
Axial vibration damper oil	Pressure	Chamber aft side	PT2721A	ALM	L	1.7 bar	60	
		Chamber fore side	PT2722A	ALM	L	1.7 bar	60	
Cylinder lubricating oil	Diff. pressure	Filter	PS3121A	ALM	L	0.5 bar	0	
Fuel oil (see Viscosity-Temp. Diagram 0710-1)	Temperature ⁴⁾	before supply unit	TE3411A	ALM	H	50-160°C	0	
				ALM	L	20-130°C	0	
	Pressure	before supply unit	PT3421A	ALM	L	7 bar	0	
	Viscosity ⁴⁾	before supply unit		⁵⁾	ALM	H	17 cSt	0
					ALM	L	13 cSt	0
	Temperature	Fuel pump outlet	TE3431A -34A ¹³⁾	ALM	D	-30°C ¹⁴⁾	30	
Fuel leakage monitoring	Level	Rail unit ⁷⁾	LS3444A ⁷⁾	ALM	H	max.	0	
		Supply Unit	LS3426A	ALM	H	max.	0	
		ICU/Fuel Pipe	LS3446A	ALM	H	max.	0	
Exhaust gas	Temperature	after each cylinder	TE3701A -07A ¹¹⁾	ALM	H	515°C	0	
				ALM	D	±50°C	0	
				SLD	H	530°C	60	
				SLD	D	±70°C	60	
		before each TC ⁶⁾	TE3721A -22A ¹¹⁾	ALM	H	515°C	0	
				SLD	H	530°C	60	
		after each TC ⁶⁾	TE3731A -32A ¹¹⁾	ALM	H	480°C	0	
				SLD	H	500°C	60	

Operating Data Sheet
Alarms and Safeguards at Continuous Service Power

Medium Performance	Physical unit	Location	Signal No. 1)	Function 2)	Type of signal 3)	Setting value [bar / °C]	Function time delay [sec]
Scavenge air	Temperature	Air receiver after cooler	TE4031A -32A	ALM	L	25°C	0
				ALM	H	50°C	0
				SLD	H	60°C	60
	Temperature	each piston underside (fire detection)	TE4081A -88A	ALM	H	80°C	0
Condensation water	Level	Scavenge air receiver	LS4071A -72A 15)	ALM	H	max.	0
				SLD	H	max.	60
			LS4075A -76A 15)	ALM	H	max.	0
				SLD	H	max.	60
Starting air	Pressure	Engine inlet	PT4301C	ALM	L	12 bar	0
Air spring air 8, 9)	Pressure	Distributor	PT4341A	ALM	H	7.5 bar	0
				ALM	L	5.5 bar	0
				SLD	L	5 bar	60
			PS4341S	SHD	LL	4.5 bar	0
Leakage oil of air spring air	Level	Exhaust valve air spring	LS4351A	ALM	H	max.	0
Control air normal supply 8)	Pressure	Engine inlet	PT4401A	ALM	L	6 bar	0
			PT4411A	ALM	L	5.5 bar	0
	safety supply 9)	Pressure	Engine inlet	PT4421A	ALM	L	5 bar
Fuel pump actuator ²¹⁾	Failure	CV7231C (A1)	XS5046A	ALM	F	-	0
		CV7232C (B1)	XS5047A	ALM	F	-	0
WECS-9520 control system	Power failure	Power supply box E85	XS5056A	ALM	F	-	0
Cylinder lubricating system	Power failure	Power supply box E85	XS5058A	ALM	F	-	0
Engine performance data overspeed	Speed	Crankshaft	ST5111S -12S	SHD	H	110%	0
Turbocharger overspeed	Speed	TC casing ²²⁾	ST5201A -02A	ALM	H	97%	0

Remarks to alarms and safeguards:

- 1) Signal number indicates interface to remote control (see [4003-3](#)).
- 2) Function:
SLD = Slow down
SHD = Shut down
ALM = Alarm
- 3) Type of signal:
D = Deviation
F = Failure
H = High
L = Low
LL = Very Low
- 4) Alternative design.
- 5) Not included in standard engine scope of supply.
- 6) Other abbreviations:
TC = Turbocharger
SAC = Scavenge Air Cooler
- 7) Location of measurements and signal numbers see [8016-1](#) 'Servo oil leakage system' and [8019-1](#) 'Fuel leakage system'.

Alarms and Safeguards at Continuous Service Power

- 8) Board system supply for control and air spring air through the pressure reducing valve 23HA.
- 9) Starting air pipe supply upstream of the shut-off valve (from starting air bottles 9.01) for control and air spring air through pressure reducing valve 19HA.
- 10) Alarm and slow-down are effective only above 40% engine power.
- 11) Signal designation changes after amplifier (on engine) from TExxxxA to TIxxxxA.
- 12) Alarm is effective only above 30% engine power.
- 13) Alarm is effective only above 40% engine power.
- 14) Deviation from median (acts as 'no flow' detection).
- 15) With 4 level switches.
- 16) Setting value:
IMO TIER II = 80°C
- 17) Sensor adjustment: adjustment-screw in position MAX
- 18) Concentration high = contact open; two different switch types: Schaller Visatron and Graviner MK6
- 19) Concentration high = contact closed; two different switch types: Schaller Visatron and Graviner MK6
- 20) Unit failure = contact open
- 21) Only for actuator Heinzmann StG10-01
- 22) Turbocharger overspeed detection from sensor ST5201-02C; specifications see ST5201C
- 22) The alarm value can be different. For the applicable setting value, refer to the specification of the damper manufacturer.

Operation

Manoeuvring

1. General

Correct maneuvering, which causes an increase in engine load up to service power and a decrease in load from service power, is very important. Engine loads in the higher power ranges that are changed too quickly can cause increased wear and fouling, specially piston rings and cylinder liners.

Slow load changes let the piston rings adapt to the new conditions and therefore make sure of the best sealing.

There must always be sufficient power available in a short time for safe manoeuvring in ports and waterways.

2. Maneuvering

Maneuvering is the operation between leaving port and release to SEA SPEED and from the approach to port until FINISHED WITH ENGINE. This also includes all changes during usual service e.g. changes of direction.

The manoeuvring range is the speed range between FULL AHEAD and FULL ASTERN. This range is usually divided into four manoeuvring steps with related given speeds in each direction.



Remark: Because of torsional vibration, it is possible that the engine has more than one barred speed range. Also, it is possible that the engine has a barred speed range if the axial damper becomes defective. Data about the barred speed range can be found near the telegraph on the bridge, and/or near the local control panel.

Usually, the FULL maneuvering speed, for engines that have fixed pitch propellers, is related to approximately 70% of the maximum rated engine speed. This is approximately 35% of the maximum power. This means that when sailing straight ahead, the ship will be at approximately 66% of its maximum speed.

A fully serviceable engine can be manoeuvred in the range given above with no time or performance limits. Fuel and scavenge air necessary for engine operation are controlled electronically.

With controllable pitch propellers the speed and torque can be freely selected. During maneuvering, the limits are the same as for fixed pitch propellers. The time period to change the propeller pitch position from zero pitch to FULL must be a minimum of 20 seconds.

If the engine is increased quickly to FULL maneuvering speed (or the propeller blades brought to FULL pitch), the momentary engine load is higher when the vessel is at standstill. When the vessel is at sea speed, the engine load is decreased.

You can do maneuvering operations from the bridge (if the remote control is installed), from the engine control room or at the local control panel on the engine.

Make sure that you know the special precautions for maneuvering operations from the local control panel.

Heavy fuel oil or diesel oil can be used during maneuvering, but heavy fuel oil is recommended (see 0270-1, paragraph 1 General).

The fuel used must have sufficient treatment (see Fuel Treatment, Fuel Oil System 0720-1).

The data given in 0250-1, Operating Data Sheet is also applicable during manoeuvring.

Manoeuvring

When heavy fuel oil is used for maneuvering, the fuel must be heated sufficiently. This keeps the viscosity at the fuel pump inlets in the range given in the Viscosity-Temperature Diagram [0710-1](#).

The heating of the fuel oil system must stay set to on. Keep the temperature of the cooling media as close as possible to the higher limits given for usual service (see Operating Data Sheet 0250-1).

2.1 Reversing during usual operation, at control room manoeuvring console

Because different remote controls can be connected to the engine controls, data about the operation from the manoeuvring stand in the control room is not given here. For this operation, see the documentation of the remote control manufacturers.

2.2 Reversing at local control panel

(see also Local Control Panel [4618-1](#) and [4003-1](#) 'Engine local control')

Transfer and take-over from REMOTE AUTO. CONTROL (Remote Control) to LOCAL MANUAL CONTROL (Local Control):

- ⇒ At the control room console, push the button LOCAL MANUAL CONTROL (Local Control) for mode transfer to local manual control.
- ⇒ At the WECS-9520 manual control panel (see [4618-1](#)), push the button LOCAL MANUAL CONTROL to take over the control.
- ⇒ Push the button FUEL CONTROL MODE.

Use this operation mode for long periods only when necessary e.g. until speed control system defects or other defects in the remote control can be repaired.

In installations with controllable pitch propellers or clutch couplings, more precautions are necessary. There must be good communication between the bridge and the local manoeuvring stand.



Remark: Because the speed control system is not in control of the engine speed, an engineer must stay at the local manoeuvring stand. The engineer can then make changes immediately if necessary.

Reversing:

- ⇒ Turn the rotary button to 15% fuel injection quantity (see display).
- ⇒ Push the button START AHEAD or START ASTERN until the engine runs in the applicable direction.



Remark: On ships under way, this procedure can be some minutes, because the propeller is dragged in the opposite sense of rotation.

You can also use the ECR manual control panel to do the reversing procedure given above.

You can use the buttons and rotary button only at the related active control stand (see [4618-1](#) 'WECS-9520 Manual control panel').

Manoeuvring

2.3 Installations with controllable pitch propeller

For data about installations with controllable pitch propellers, refer to the documentation of the propeller manufacturer.

2.4 Installations with clutch couplings

You must make sure that the couplings are engaged before you start the engine.

3. Increase power after release to SEA SPEED and decrease

You must only increase and decrease the engine load during a given time period. This time period is usually between 40 minutes to 45 minutes between full maneuvering and service power. However, the time period must not be less than that given as follows:

- For an increase in engine load, not less than 30 minutes
- For a decrease in engine load, not less than 15 minutes.

You use the related devices in the engine room to manually increase and decrease the engine load as follows:

- For fixed pitch propeller installations:
 - Speed setting.
- For controllable pitch propeller installations:
 - Speed setting
 - Propeller pitch setting lever
 - Speed and propeller pitch setting lever (combinator).

The time limits given above for speed and power are not applicable if a faster decrease of engine load is necessary when:

- There are critical alarm conditions in the engine room
- A shut-down or automatic slow-down signal is activated.

4. Emergency manoeuvre

The safety of the vessel is very important. If an emergency manoeuvre is necessary, all the limits specified in paragraphs 2 and 3 are not applicable, i.e. you can use the the full power of the engine.

Intentionally blank

Operation

Change-over from Diesel Oil to Heavy Fuel Oil and Back

1. General

Continuous operation with heavy fuel oil is recommended for engines and plants. You must only change from heavy fuel oil to diesel oil if necessary, for example when:

- The engine is flushed before maintenance
- The heating plant is set to off in the dry dock
- There are environmental conditions.

To make sure that the change-over is safe, see the paragraphs that follow:

2. Recommended viscosity at inlet to fuel pumps

For the temperature necessary to make sure that the fuel upstream of the inlet to the fuel pumps is at the correct viscosity, see the Viscosity-Temperature Diagram [0710-1](#).

A viscosimeter controls the temperature increase of the fuel.



Remark: During engine standstill fuel flows through the fuel pumps on the supply unit but not through the fuel rail. Change-over is thus not possible.

2.1 Change-over from diesel oil to heavy fuel oil

See [0720-1](#) Fuel Treatment, Fuel Oil System, Fig. 'B'.

Plant side

After the position of the three-way valve 21 is changed, there is a mixture of diesel oil (DO) and heavy fuel oil (HFO) in the mixing unit 24.

The viscosimeter controls the end-heater 26, which keeps the fuel temperature at the necessary viscosity. You must only increase the fuel temperature slowly (i.e. the temperature increase must be a maximum of 2°C each minute).



Remark: It is possible that sudden temperature changes can seize the fuel pump plungers.

Make sure that the heating for the fuel filter 27, fuel supply and fuel return pipes is set to on until the fuel is at the necessary temperature (the temperature is shown on the thermometer upstream of the inlet to the fuel pumps).

Do a check of the fuel pressure downstream of the low pressure feed pump and at the fuel pump inlet (see Operating Data Sheet [0250-1](#)).

Engine side

The trace heating on the engine (fuel pressure pipes and fuel rail) must be set to on when there is a change-over from diesel oil to heavy fuel oil in the plant. All covers of the rail unit must be closed.

If the engine room is cold, you must set to on the trace heating approximately one hour before the change-over.

Before you stop the engine, the change-over procedure must be fully completed. This prevents a mixture of diesel oil and heavy fuel oil in the fuel rail, which can cause viscosity problems during the next engine start.

It is recommended that for the change-over, the fuel is at the necessary temperature and the CMCR load is not more than 75%.

Change-over from Diesel Oil to Heavy Fuel Oil and Back

2.2 Change-over from heavy fuel oil to diesel oil

Plant side

To change from HFO to DO, you must first change the position of the 3-way valve 21. HFO and DO is mixed in the mixing unit 24. The viscosity of the fuel mixture decreases quickly at a specified temperature, which is related to an increased proportion of DO to HFO. After a short period the heating can be set to off.

Engine side



Attention! If you operate the engine with diesel oil and the trace heating is set to on, damage to the engine will occur.

The trace heating on the engine (fuel pressure pipes and fuel rail) must be set to off during change-over from HFO to DO in the plant.



Remark: The time to complete a change-over will be longer if the engine operates at low load.

Before you stop the engine, the change-over procedure must be completed. This will prevent a mixture of DO and HFO in the fuel rail which can cause viscosity problems during the next start.

It is recommended that the CMCR load is less than 50% CMCR power for the change-over from HFO to DO.

Operation

Operation at Low Load

1. General

See the data that follow:

- Checks and precautions in [0240-1](#).
- Trace heating of the fuel oil system during operation.
- Temperature of cooling medium within the usual range (see Operating Data Sheet [0250-1](#)).
- Careful treatment of the fuel oil (see Fuel Treatment, Fuel Oil System [0720-1](#)).
- [0750-1](#) Operating Media, paragraph 3 Cylinder Lubricating Oil.

The cylinder lubricating oil quantity automatically adapts to the lower engine load. The WECS-9520 controls the lubricating oil quantities related to the engine load.

2. WECS-9520 Injection control

At low load the WECS-9520 automatically cuts out one of the three injection valves in each cylinder. At very low load, two of the three injection valves are cut out.

This makes sure that the engine has the best fuel mist and combustion properties, which decreases smoke from the funnel and fuel consumption.

The WECS-9520 changes the cutting out of the three injection valves at regular intervals to get an equal thermal load in the combustion chamber.

There is no time limit to operate the engine at low load.

Intentionally blank

Operation

Operation at Overload

1. General

Usually, the engine is only operated at overload (110% of CMCR power) during sea trials when there is an authorized representative of the engine builder on board the ship.

The limit for operation of the engine at overload is a maximum of one hour each day (see also The Relation between Engine and Propeller 0070-1).

During operation at overload, you must carefully monitor the engine. If there are unusual indications, you must decrease the load (power).

The load indication (fuel injection quantity) and the exhaust gas temperature upstream of the turbine show the engine load (see Operating Data Sheet 0250-1 and Acceptance Records).

The coolant temperatures must be kept in their usual ranges.

In usual service, the full load position of the load indication (fuel injection quantity) must stay in the limits given (see the Acceptance Records).

The maximum permitted position of the load indication (fuel injection quantity) is given in the Acceptance Records. The adjustments are only permitted to show the CMCR power, during sea trials with an overspeed of 104% to 108% of CMCR power.

The conditions given below have an effect the speed of the ship:

- Sailing into strong head winds
- Sailing in heavy seas
- Sailing in shallow water
- When there is unwanted heavy growth on the hull.

The governor increases the fuel quantity to keep the speed of the ship constant. The position shown on the load indication (fuel injection quantity) will increase.

Intentionally blank

Engine Shutdown

General

1. Engine load decrease

When possible, we recommend that the engine load is decreased slowly, see Maneuvering [0260-1](#).

2. Engine stop

From the control room – remote control:

Because different types of remote control can be connected to the engine controls, we do not give a procedure of the operation from the manoeuvring stand in the control room. For this procedure, see the applicable documentation of the remote control manufacturer.

Usually, it is sufficient to move the telegraph to the position STOP.

From the control room – ECR manual control panel:

When you push the STOP button on the WECS-9520 manual control panel in the ECR, the WECS-9520 decreases the engine speed/power, then shuts down the engine.

From the local control panel:

See the Control Diagram [4003-2](#) and Local Control Panel [4618-1](#).

When you push the STOP button on the WECS-9520 manual control panel the WECS-9520 decreases the engine speed/power, then shuts down the engine.



Remark: You can use the buttons and rotary knob only at the related active control stand.

2.1 In an emergency

To stop the engine immediately, push the EMERGENCY STOP button in the control room, or on the local control panel. The fuel pressure control valve 3.06 releases the pressure in the fuel rail. At the same time, the fuel pump actuators move the regulating linkages to the zero position.

2.2 Last option to stop the engine



Attention! Do this emergency procedure only as a last option.

You can also stop the engine as follows:

- In the supply box E85, set to off the electrical power to the WECS-9520.

Intentionally blank

Engine Shutdown

Procedures after Engine Stop

1. Procedures for shorter service breaks (some days to a some weeks)

1.1 Engine is maneuverable

If the engine must still be maneuvered after it has stopped, see the conditions that follow:

- The WECS-9520 engine control system must stay set to on.
- All the pumps for coolant water, lubricating oil and fuel must operate.
- Control air must be available and the starting air bottles must be full.
- Keep the cylinder cooling water at the correct temperature.
- Do not cool the lubricating oil.
- Keep the fuel at the necessary temperature in accordance with the Viscosity-Temperature Diagram [0710-1](#).

1.2 Engine is not maneuverable

If the engine is not maneuverable, see the conditions that follow:

- After the engine has stopped, the coolant water and lubricating oil pumps must operate for a minimum of 20 minutes to let the temperatures become stable. Do not let these media cool below their usual inlet temperatures. The sea-water pump can, thus, usually be stopped immediately.
 - If the engine was shut down during operation with heavy fuel oil, then the supply must flow through the fuel pumps and the fuel rail. The fuel system must continue to operate.
 - The fuel pipe heating system at the engine must be set to on. If this is not necessary, change the engine operation to diesel oil before shut-down (see [0270-1](#) 'Change-over from heavy fuel oil to diesel oil' and Measures to be taken before Putting Out of Service for Extended Period [0620-1](#)).
 - The low pressure feed pump and booster pump can be stopped, if the engine was shut down during operation with diesel oil (see [0720-1](#) 'Layout of the fuel oil system').
 - Open the indicator valves in the cylinder covers.
 - The turning gear can be engaged.
 - WECS-9520 engine control system can be set to on.
 - Where possible, keep the cooling water warm to prevent the engine from cooling down too much. The cooling water pump thus, continues to operate unless it is necessary to stop the pump for maintenance.
- ⇒ At frequent intervals and with the indicator valves open, use the turning gear to turn the engine as necessary (possibly done daily in damp climates). Do this procedure while the lubricating oil pump and servo oil service pump operate and set to on the cylinder lubrication at the same time. After completion of this procedure, make sure that the piston stops in a different position each time.



Remark: Make sure that you know the safety precautions before you do repair work or overhauls (see Maintenance Manual 0011-1 and 0012-1). If necessary, release the pressure from the fuel oil system.

⇒ Repair all the defects found in service (leaks, etc).

Procedures after Engine Stop

Starting air manifold venting / Stop the starting air system:

Because of low air pressure after engine stop, the venting of the starting air manifold 6 cannot be done correctly. Thus, dirt and grease stay in the starting air manifold and can cause the piston rings of the starting air valve 7 to stick.

Use high-pressure air at regular periods, to make sure that all dirt and grease is removed from the starting air manifold.

Do the steps that follow:

- ⇒ Engage the turning gear.
- ⇒ Open the drain and test valve 3 momentarily. If you can hear the starting air flow into the shut-off valve 1, close the drain and test valve 3. The starting air manifold 6 is pressurized with high-pressure starting air.
- ⇒ Close the shut-off valves of the starting air bottles.



Remark: You can usually find the venting valve 5 installed at the free end of the starting air manifold. But on some engines the venting valve is installed at the driving end. It is possible that two venting valves are installed on different engine types.

- ⇒ Open the venting valve 5. The high-pressure air is released. Dirt and grease in the starting air manifold are removed.
- ⇒ Lift the lever then turn the handwheel 2 to position CLOSED.
- ⇒ Open the venting valve 4 to drain the shut-off valve 1.

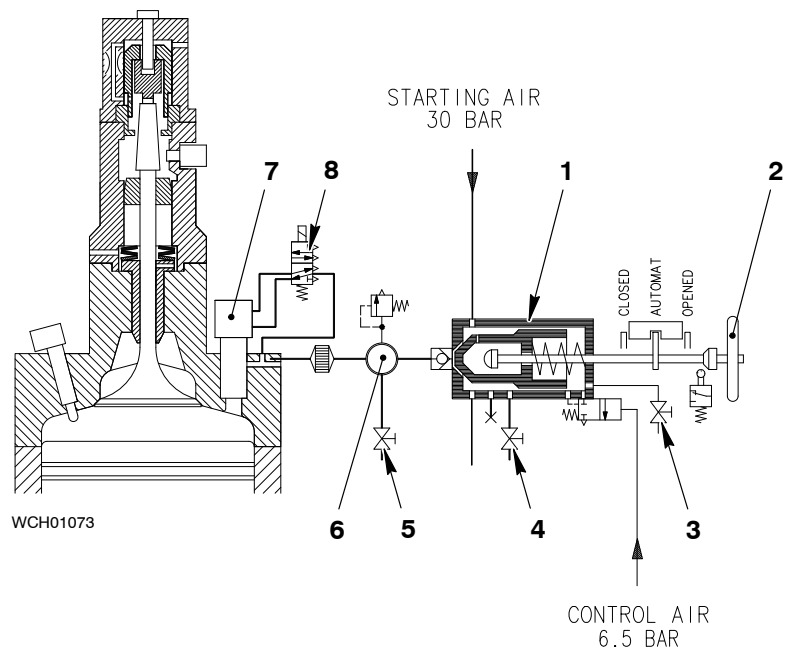

Key to Illustration:

- 1 Shut-off valve for starting air
- 2 Handwheel for shut-off valve
- 3 Drain and test valve 2.06
- 4 Venting valve 2.21

Starting air system

- 5 Venting valve 2.27
- 6 Starting air manifold
- 7 Starting air valve
- 8 5/2-way solenoid valve

Engine Shutdown

Procedures after Engine Stop

Post-lubrication of the cylinders:

Post-lubrication starts automatically during slow-down of the engine (speed below 8%).

⇒ Close the shut-off valve on the control air supply (supply of air from the board system).



Remark: Make sure that the lubricating oil pump is set to off before you bleed the air spring system.

2. Procedures for service breaks for a longer period (weeks or months)

Refer to paragraph 1.2 above and to Measures to be taken before Putting Out of Service for Extended Period [0620-1](#).

Intentionally blank

Special Measures in Operation

Running-in of New Cylinder Liners and Piston Rings

Overview

1.	General	1/4
2.	Fuel	2/4
3.	Cylinder Lubricating Oil	2/4
4.	Cylinder Lubricating Oil Feed Rate	3/4
5.	Running-in Sequence	4/4

1. General

After new components of the piston running system are installed, it is very important that you do a running-in procedure. This procedure makes sure that the profiles of the piston rings and the cylinder liner adapt and get the same shape.

The running-in procedure has different engine load steps (see Fig. 1), which are lubricated more than usual. The higher amount of lubricating oil absorbs the large quantity of wear debris, which were made during the running-in procedure.

The new components will be run-in until the engine has the maximum load. If the engine was run-in until load L1 and you want to operate the engine at a higher load L2 ($L2 > L1 + 10\% \text{ CMCR}$), you must first start a new running-in process until load L2. For data about the engine load ranges, see 0070-1 The Relation between Engine and Propeller.

After new cylinder liners are installed, or after piston rings are replaced, a running-in procedure must be completed. Running-in makes sure that there is good sealing of the piston rings in a short time. The running-in procedure is very important for engines with non-chrome ceramic piston rings.

It is very important that no scuffing occurs on the running surfaces of the cylinder liner and/or the piston rings during the running-in procedure. You must obey the data given in the guidelines of the running-in programme (see paragraph 5) to run-in new components. Do not complete the load-up programme faster than recommended.

It is also very important that spare cylinder liners are purchased from approved manufacturers who apply modern material and machining technologies.

1.1 Before Engine Start

1. Prepare the engine for start, see 0110-1.
2. Do a check of the condition of the piston rings.
3. Do a check of the condition of the cylinder liners from the piston underside and for signs of condensation or leakage (if the engine has not started for some time).
4. Do a check of the scavenge air receiver and piston underside for contamination.
5. Make sure that the water separator is in a clean condition.
6. Make sure that the scavenge air receiver drains are open and the high level alarm operates correctly.
7. See the data given in paragraph 4 to set the cylinder lubricating oil supply rate.

Running-in of New Cylinder Liners and Piston Rings

8. In the remote control system, get the USER PARAMETERS in the USER page (see [4002-3](#), User parameters and Maintenance Settings).
9. Set to off the VIT.
10. Set the FQS to 0.00 degree.

1.2 Running-in

1. See paragraph [5](#) for data about the running-in sequence.
2. Do not complete the load-up sequence faster than the recommended time.



Remark: It is usually necessary to inspect the condition of the running surfaces of the piston rings and the cylinder liner to make an estimate of the running-in status.

3. Do frequent checks to make sure that the cooling water quantity and temperature is stable (differences in temperature are not permitted), (see [2124-1](#) Cylinder Liner).
4. For the running-in of one cylinder, you can temporarily decrease its load. See step a) and step b):
 - a. In the remote control, get in the MAINTENANCE SETTINGS in the ADJUST page (see [4002-3](#), User parameters and Maintenance Settings).
 - b. In the Inj. correction factor page, set the applicable value.

2. Fuel

For running-in, use heavy fuel oil (HFO). Make sure that the fuel has the correct treatment and viscosity (i.e. heated to the correct temperature).

3. Cylinder Lubricating Oil

For usual operation and running-in conditions, use cylinder lubricating oil that has a high-alkaline base number (BN) (see [0750-1](#), paragraph 3 Cylinder Lubricating Oil) when HFO with a high sulphur content is used.

Running-in of New Cylinder Liners and Piston Rings

4. Cylinder Lubricating Oil Feed Rate

4.1 Increase Feed Rate

During the running-in period, the feed rate to the related cylinder must be increased to 1.4 g/kWh (see 7218-1 paragraph 8.4 Lubricating Oil Feed Rate – Adjustment).

1. In the remote control system, get the USER PARAMETERS in the USER page (see 4002-3, User parameters and Maintenance Settings).
2. In the Lubrication field, select the applicable cylinder(s).
3. In the Adjustment column, adjust the feed rate until 1.4 g/kWh shows in the Feed Rate column for the applicable cylinder number.

4.2 Decrease the Feed Rate

For maximum power, the feed rate can be decreased to (see Fig. 1):

- 1.2 g/kWh after approximately 15 hours of operation
- 1.0 g/kWh after 50 hours of operation
- 0.9 g/kWh after 200 hours of operation and after inspections of the piston rings and cylinder liners.

Because of regular checks of the piston rings and cylinder liners during the next 500 hours to 1000 hours of operation, the feed rate can be decreased. The feed rate must be decreased in small steps until the guide feed rate is at 0.8 g/kWh (see paragraph 5, Running-in Sequence).

4.3 Decrease the Feed Rate to Less than the Guide Feed Rate

If there are satisfactory conditions after 1000 hours of operation, it is possible to decrease the feed rate to less than the guide feed rate.

You must decrease the feed rate in steps of approximately 0.1 g/kWh, with periods of 500 hours to 1000 hours of operation between each step.

If the inspection results of the running surface of the piston rings and cylinder liner (through the scavenge ports) are satisfactory, the feed rate can be decreased.

The data above for usual operation is related to:

- The condition of the engine
- The sulphur content of HFO
- The cost of cylinder lubricating oil compared to a replacement cylinder liner and maintenance costs
- The selection of lubricating oil
- The oil analysis of the piston underside drain.

Running-in of New Cylinder Liners and Piston Rings

5. Running-in Sequence

Note: If the engine operates at low load (less than 60% CMCR), the running-in procedure can be done at a later time. But, this is only possible when a full set of Chrome Ceramic rings (obey the data given in the Service Bulletins RT-135 and RT-135_A1) is installed together with a new, fully honed cylinder liner (or a cylinder liner that was run-in before).
 At the next load-up (e.g. procedure to clean the turbocharger or boiler soot removal) the running-in procedure must then be completed and must include 75% engine load before the ship goes back to low load operation again.

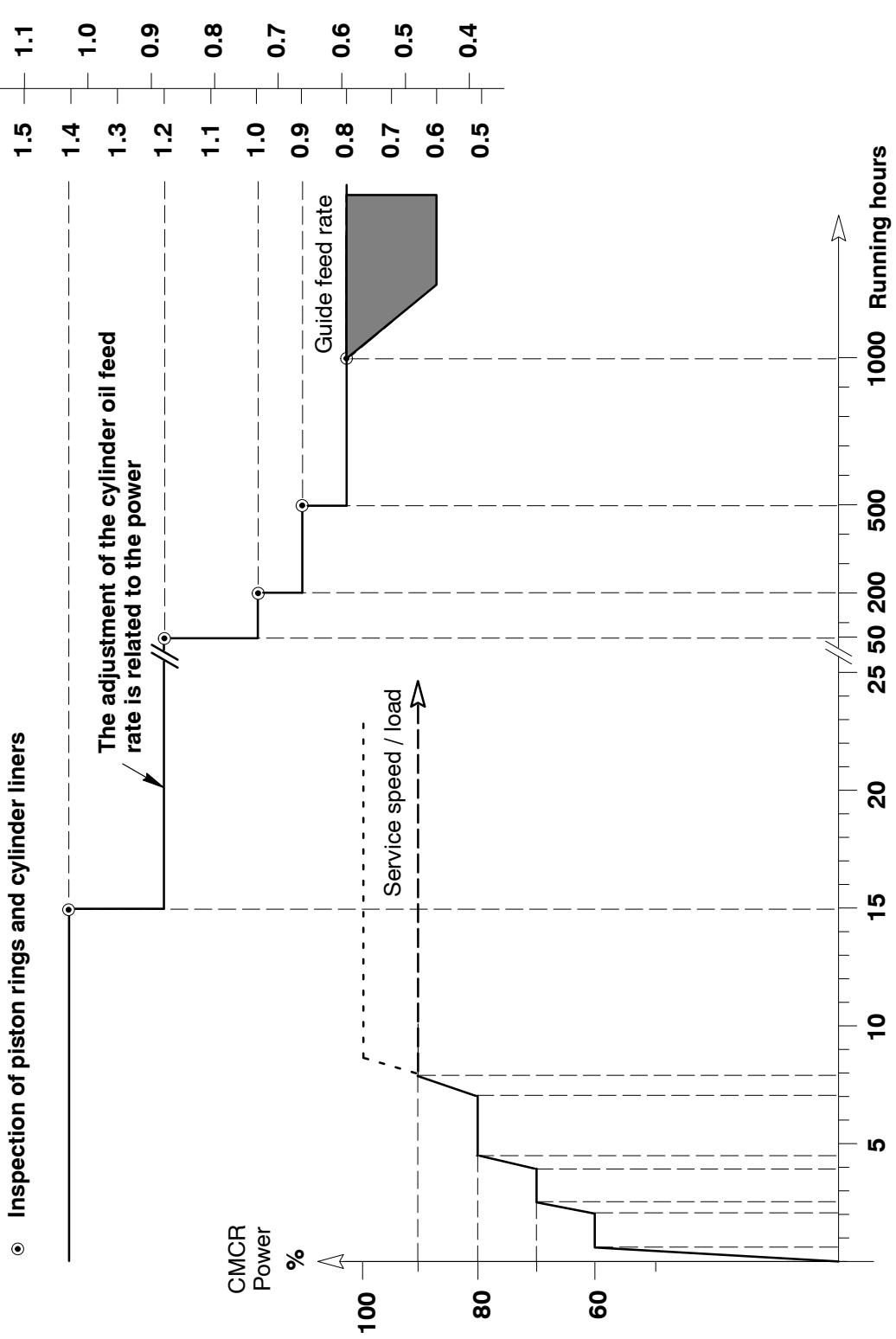

Fig. 1: Running-in Sequence – Pulse Lubricating Systems¹⁾

Note to Fig. 1

1.) Approved for pulse feed lubricating systems, pulse jet lubricating systems and retrofit pulse lubricating systems.

Special Procedures during Operation

Indicator Diagrams

1. General

Indicator diagrams must only be drawn with a serviceable indicator at constant power and speed, and ships sailing in calm sea and deep water.

To give you data about the indication diagrams, make a note of the related cylinder number, engine speed, the positions of the load indicator and VIT..

2. Description of cylinder pressures

Higher compression ratio and fuel injection delay are used to decrease the NO_x value for engines so that the IMO rules are obeyed.

The ratio of the maximum firing pressure to the compression pressure is in the range of 0.90 to 1.25 at 100% load.

The engine rating is related to IMO tuning. This means that the curves in the diagram can be different within the two examples that follow:

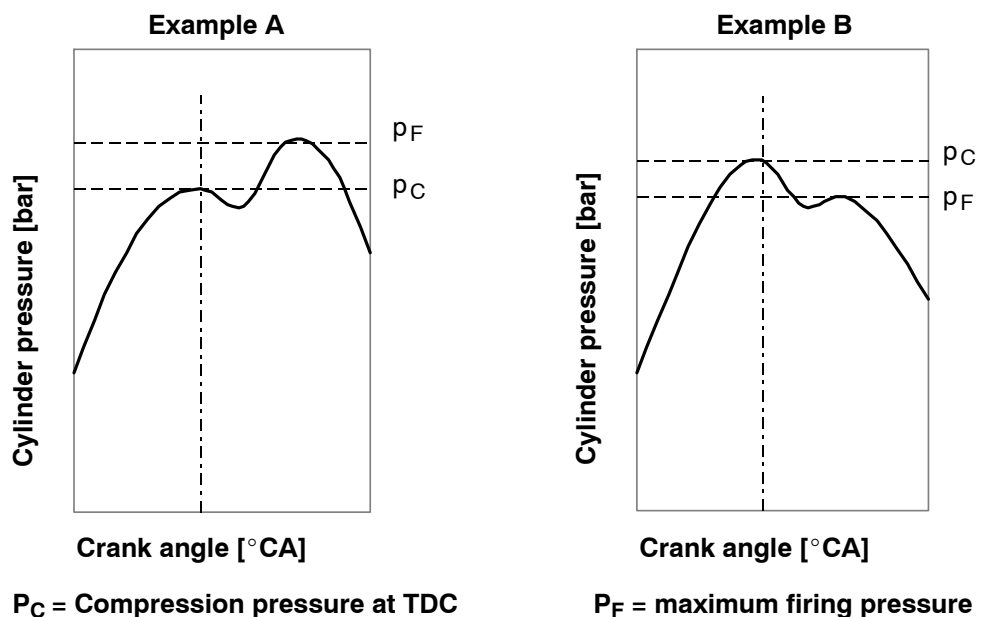

3. Indicator diagrams and related engine adjustments



Remark: The diagrams, which were made during the acceptance trial, must be used as references. For reference values about compression and maximum firing pressures for the related load and speed, refer to the trial reports and performance curves.

Indicator Diagrams

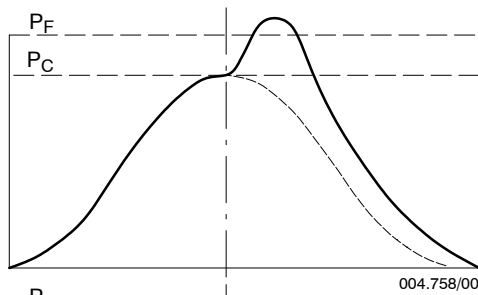

Example A

3.1 Maximum firing pressure is too high at the correct compression pressure

Possible causes:

- Ignition (start of injection) too advanced for the fuel type in use.
- ⇒ In the user parameters, enter a positive setting to adjust the FQS to "later" to correct the ignition pressure (see user parameters [4002-3](#)).

You can only do a correction of the FQS if all cylinders show the same pressure difference.

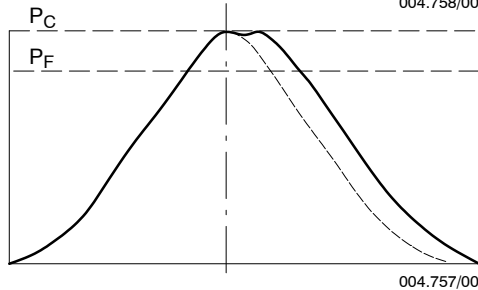

Example B

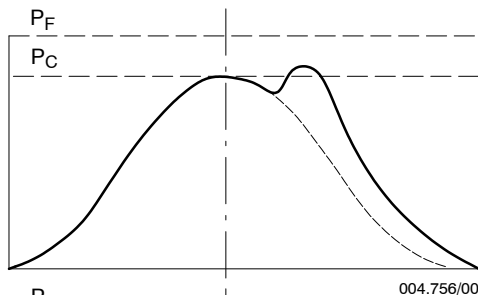

Example A

3.2 Maximum firing pressure is too low at the correct compression pressure

Possible causes:

- Unsatisfactory combustion: Nozzle tip has trumpets is worn.
- ⇒ Do a check of the injection nozzles.
- Ignition (start of injection) too retarded for the fuel type in use.
- ⇒ In the user parameters, enter a positive setting to adjust the FQS to "earlier" to correct the ignition pressure.

You can only do a correction of the FQS if all cylinders show the same pressure difference.

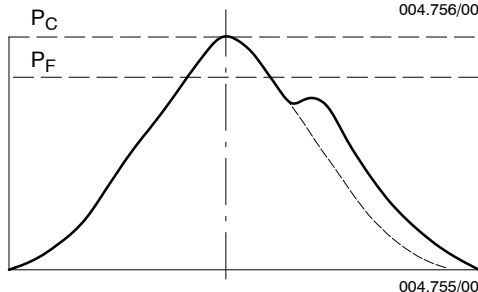

Example B

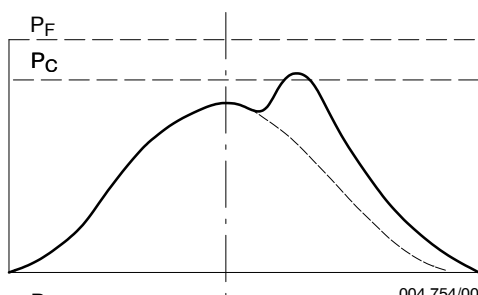

Example A

3.3 Compression and maximum firing pressure too low

Possible causes:

- The load is less than you think.
 - The exhaust valve has a leak.
- ⇒ Do a check of the exhaust valve.
- The scavenge air pressure too low.
- ⇒ Clean the turbocharger or scavenge air cooler.
- The suction temperature too high.
 - VEC timing is incorrect i.e. exhaust valve closing time too late (parameter in WECS-9520).

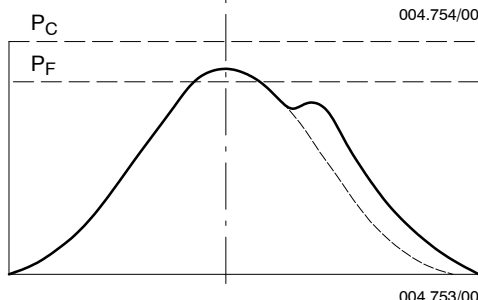

Example B

Indicator Diagrams

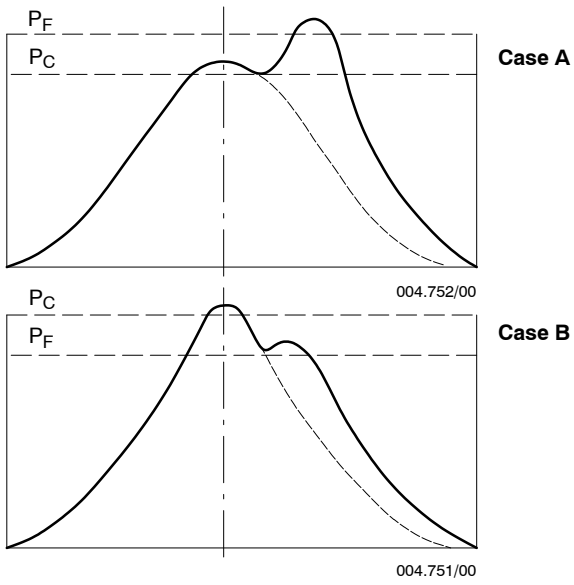

3.4 Compression pressure and maximum firing pressure too high

Possible cause:

- Engine has too much load.
- VEC timing incorrect.

Intentionally blank

Special Procedures during Operation

Procedures to Prevent Contamination and Fire in the Scavenge Air Spaces

1. General

The primary cause of contamination is when combustion materials are blown between the piston and cylinder into the scavenge air spaces (blow-by). The contamination will be more if the fuel is not fully burned (exhaust smoke).

2. Causes and procedures

2.1 Causes of unsatisfactory combustion

- The injection valves do not operate correctly (nozzle tip has trumpets or is worn).
- The fuel is too cold, specially at low load.
- Operation with a temporarily low air supply during large differences in engine load and the scavenge air pressure fuel limiter set too high.
- Too much load.
- Low air supply because the ventilation in the engine room is not sufficient.
- Contamination of the silencer and diffuser on the air side of the turbocharger.
- Contamination of the wire mesh and nozzle ring upstream of the turbocharger.
- Contamination of the exhaust gas boiler, the air cooler and water separator, the air flaps in the scavenge air receiver and the scavenge ports.

2.2 Causes of blow-by

- Worn piston rings, broken piston rings or piston rings that cannot move.
- Worn cylinder liner.
- Incorrect operation of a lubricating quill.
- The running surface of the cylinder liners are damaged.

If there are one or more of these conditions, the remaining particles (fuel not fully burned and cylinder lubricating oil) will collect at the areas that follow:

- Between piston ring and piston ring groove.
- On the piston skirt.
- In the scavenge ports.
- On the bottom of the cylinder block (piston underside).

2.3 Causes of fires

- Combustion gases and sparks that bypass the piston rings between the piston and cylinder liner running surface go into the piston underside.
- If sealing rings of the piston rod gland leak and drain pipes from the piston underside are blocked, system oil and cylinder lubricating oil will collect. This is a primary fire risk.



Remark: Do periodic checks of the bottom of the cylinder block and scavenge air receiver. If necessary clean the cylinder block and scavenge air receiver.

Procedures to Prevent Contamination and Fire in the Scavenge Air Spaces

2.4 Indications of a fire

- You can hear the related temperature alarms.
- A large increase in the exhaust gas temperature of the related cylinder and an increase in piston underside temperature.
- In some conditions the turbocharger can surge.

2.5 Fire fighting procedures

We recommend the procedures that follow:

- ⇒ Decrease the engine power.
- ⇒ Cut out the injection of the related cylinder (in the remote control, user parameters, select Inj. CUT OFF).
- ⇒ Although there is high temperature in the cylinder(s), increase the feed rate of lubricating oil to maximum (see 4002-3 'User Parameters and Maintenance Settings' paragraphs 1 and 1.1).

If the plant has a specified fire extinguisher system, (carbon dioxide CO₂) the containers can be attached to the applicable connections on the scavenger air receiver. The related shut-off valve must be fully leak-proof.

- ⇒ If you think there is a fire, shut down the engine and fill the scavenge space with CO₂ gas.



Remark: Make sure that you read 0210-1 Safety Precautions and Warnings, paragraph 11 Carbon Dioxide (CO₂) gas.

If steam is used to extinguish a fire, you must do the procedures to prevent corrosion.

It is possible that after approximately 5 minutes to 15 minutes, a fire will be extinguished. To make sure that a fire is extinguished, do a check of:

- The exhaust gas temperatures
- The temperatures of the doors to the piston underside space.

After the procedures above, you must stop the engine as soon as possible and find the cause of the fire.

CHECK

Do the checks that follow:

- The cylinder liner running surface, piston and piston rings.
- The air flaps in the scavenger air receiver (replace if necessary).
- Possible leakages.
- The piston rod gland as much as possible.
- The injection nozzles.

⇒ After a careful check, or if necessary a repair, do the procedure that follows:

- Start the engine.
- Start the injection and slowly increase the load.
- Set the lubricating oil feed rate to the applicable value.

⇒ If the engine must stay in operation and the fire is extinguished, do the procedure that follows:

- Cut in the injection and slowly increase the load.
- Set the lubricating oil feed rate to the applicable value.



Remark: Do not operate the engine for long periods with a high cylinder lubrication setting.

Procedures to Prevent Contamination and Fire in the Scavenge Air Spaces

2.6 Procedures to prevent fire

Good engine maintenance will help to prevent a fire in the scavenge air spaces. The data that follow will also help to prevent fire:

- ⇒ Make sure that the injection nozzles are serviceable (i.e. the spray from the nozzles must come out correctly).
- ⇒ Do regular inspections of the air and gas pipes.
- ⇒ Regularly clean the the air and gas pipes.
- ⇒ Dirty oil from the piston underside must always drain through the dirty oil outlet.
- ⇒ Use your hand to feel the drain pipes. If there is a blockage, a drain pipe will have a temperature difference between different areas. You must clean the related drain pipe as soon as possible.

Intentionally blank

Special Procedures during Operation

Instructions Concerning the Prevention of Crankcase Explosions

1. General

Examples of crankcase explosions in diesel engines have shown that they can only occur in special conditions, and thus do not occur frequently.

The cause of crankcase explosions is oil mist. Oil mist comes from components that have become unusually hot.

Engines have oil mist detectors (see Oil Mist Detector [9314-1](#)), which continuously monitor the concentration of oil mist in the crankcase. If there is a high oil mist concentration the oil mist detector activates an alarm.

Correct engine maintenance will help prevent explosions in the crankcase.

2. Procedure

If an oil mist detector activates an alarm, do the procedures given below:



Attention! Get away from the engine. There is a risk of explosion.

- ⇒ Decrease the engine speed (power) immediately.
- ⇒ When possible, stop the engine and let the temperature decrease for a minimum of 20 minutes.
- ⇒ Find the cause and repair if possible (see Operating Problems [0840-1](#)).



Attention! Do not open the crankcase doors or the checking covers for a minimum of 20 minutes. If air goes into the crankcase, an explosion can occur.

To prevent accidents no person must be in the possible range of gases that can come out of the relief valves on the crankcase doors. If no fire-extinguishing system is installed or not in use, a portable fire extinguisher must be kept ready when the crankcase doors are opened.

Intentionally blank

Operation during Unusual Conditions

General Data

1. General

The data below give the procedures for engine operation when:

- The parts cannot be immediately repaired
- The engine must continue to operate, or
- When engine operation must continue as soon as possible.

2. Decreased power output

In an emergency, when the engine must operate (with one or more cylinders out of operation, turbochargers out of service or decreased coolant flow etc.) the power must be decreased to prevent damage to the engine.

Make sure that the load indication is always less than the full load position (fuel injection quantity) and that the gas temperature at the turbocharger inlet is less than the maximum temperature (see Operating Data Sheet [0250-1](#)). If necessary decrease the engine speed and power.

Because of torsional vibration, it is possible that the engine has more than one barred speed range. Also, it is possible that the engine has a barred speed range if the axial damper becomes defective. Data about the barred speed range can be found near the telegraph on the bridge, and/or near the local control panel.

The exhaust smoke must be monitored because the engine must not operate with dark exhaust smoke. The speed and power must be decreased until the exhaust smoke is satisfactory.

3. Cylinders out of operation

When one or more cylinders are out of operation the turbocharger can surge. This makes a loud sound. Large differences in the scavenge air pressure will show on the pressure gage.

If the turbocharger surges for short periods or continuously, you must decrease the speed sufficiently.



Remark: When cylinders are out of operation, it is possible (when an engine has only e.g. five cylinders) that the engine will stop in a position from which it cannot start. This is because none of the serviceable pistons are in the correct position to start the engine again. Start the engine momentarily in the opposite direction to get the crankshaft to a different position. It is possible that the engine will not reverse correctly and you must do related precautions together with the bridge.

Intentionally blank

Operation during Unusual Conditions

Operation with Injection Cut Out (One or More Cylinders)

1. Cut out the injection

If the injection of one or more cylinders must be cut out, do the procedure that follows:

- ⇒ In the remote control, select Inj. CUT OFF to cut out the applicable cylinder (see 4002-3 User Parameters, paragraphs 1 and 1.1).



Remark: If there is a defect in the injection system (injection valve, high pressure pipe, etc.) only cut out the injection of the related cylinder. If possible, the exhaust valve must always operate.



Attention! For safety, disconnect the electrical connections 10 from the rail valves 9 of the related cylinder (see Fig. 'A').

If it is necessary to operate the engine with the injection cut out for a long period, do the procedure that follows:

- ⇒ Record the lubricating oil feed rate settings.
- ⇒ Decrease the lubricating oil feed rate for the related cylinder to the minimum setting.

2. Injection start

Replace defective injection control unit as soon as possible (see Injection Control Unit 5564-1 in the Maintenance Manual).



Risk of injury! You must use gloves and safety goggles when you do work on hot components.

2.1 Replace the defective injection control unit

- ⇒ Stop the engine.
- ⇒ Close the heating pipes.
- ⇒ Set to off the fuel booster pump 3.15 and the bearing oil pump.
- ⇒ Remove the screw plug 7 from the stop valve 8.
- ⇒ Carefully open the stop valve 8 to release the pressure in the servo oil rail 2 (see Fig. 'B').
- ⇒ Operate the hand lever 6 on the fuel shut-down pilot valve 5 to release the pressure in the fuel rail 1. Make sure that the fuel rail has no pressure (see Fig. 'C').
- ⇒ Replace the defective injection control unit (see 5564-1 in the Maintenance Manual).
- ⇒ Close the stop valve 8.
- ⇒ Install and tighten the screw plug 7.
- ⇒ Set to on the fuel booster pump 3.15, bearing oil pump and the servo oil service pump 4.88.

CHECK

Do a check for leaks.

- ⇒ Set to off the servo oil service pump 4.88.
- ⇒ Open the heating pipes.
- ⇒ Adjust the lubricating oil feed rate for the related cylinder to the settings you recorded before (see your recorded settings and 7218-1 'Adjusting the feed rate of lubricating oil').
- ⇒ Connect the electrical connections 10 to the rail valves 9.
- ⇒ In the remote control, select Inj. RUN to cut in the applicable cylinder (see 4002-3 paragraphs 1 and 1.1).

Operation with Injection Cut Out (One or More Cylinders)

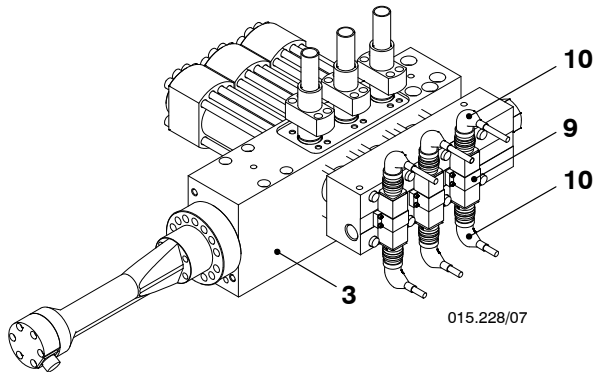
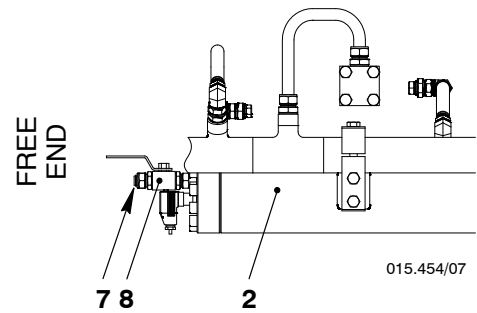
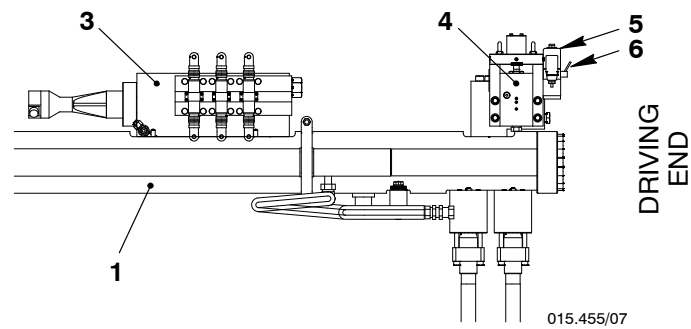
A**B****C**

Key to Illustrations:

- 'A' Injection control unit
- 'B' Servo oil rail at free end
- 'C' Fuel rail at driving end

- | | |
|------------------------------------|--------------------------|
| 1 Fuel rail 3.05 | 6 Hand lever |
| 2 Servo oil rail 4.11 | 7 Screw plug |
| 3 Injection control unit 3.02 | 8 Stop valve 3.40 |
| 4 Fuel pressure control valve 3.06 | 9 Rail valve 3.76 |
| 5 Fuel shut-down pilot valve 3.08 | 10 Electrical connection |

Operation with Injection Cut Out (One or More Cylinders)

2.2 Replace the defective injection pipe

Replace the defective injection pipe as soon as possible.



Remark: You can use the drain screws on the flange to find a defective injection pipe that leaks (see 8019-1 'Fuel leakage system' Fig. 'E' items 53 and 54).

As a temporary procedure, do as follows:

⇒ Disconnect the two electrical connections 10 from the related rail valve 9 on the injection control unit 3 to isolate the defective injection pipe.

Injection will continue to operate through the remaining injection pipes, but this makes the injection time longer and releases an alarm 'Inj. time too long'.

⇒ Stop the engine.

⇒ Replace defective injection pipe (see Fuel Pressure Piping 8733-1 in the Maintenance Manual).

Intentionally blank

Operation during Unusual Conditions

Faults in High Pressure Fuel System

Overview

1.	Defective fuel pump	1/8
2.	Defective actuator	1/8
3.	Defective injection control unit	4/8
4.	Defective fuel pressure control valve 3.06	7/8

1. Defective fuel pump

1.1 Fault identification

- Higher regulating shaft positions of the fuel pump rows at the same output compared with the acceptance report.
- Unusual noises e.g. knocks, rings and scrapes.
- The level switch LS3426A 17 shows an alarm (see 8019-1 'Fuel leakage system', Fig. 'E'). A visual examination shows a leak indication LI3427L at the leakage drain pipe.

1.2 Causes

- The pump plunger is seized, the spring is broken, the regulating sleeve is blocked.
- The roller is blocked, there is damage to the cam, the roller guide is seized.
- An HP pipe is broken.
- The regulating linkage is blocked.

1.3 Procedures

- ⇒ Stop the engine.
- ⇒ Cut out the related fuel pump (see Cutting Out and Cutting In of the Fuel Pump 5556-2).
- ⇒ Replace the defective parts as soon as possible (see Fuel Pump 5556-1 and Supply Unit 5552-2 in the Maintenance Manual).

2. Defective actuator

2.1 Fault identification

- If an actuator fails, its regulating output stays in position or turns slowly to zero supply. The toothed rack does not change when the load changes.
- At higher fuel consumption, the serviceable actuator has control of the fuel quantity regulation.
- At lower fuel consumption, the fuel pressure control valve 3.06 has the fuel pressure regulating function.



Remark: If all the actuators become defective, their regulating outputs stay in position or turn slowly to zero delivery. The toothed rack does not change when the load changes. Fuel quantity regulation is not possible at lower fuel consumption. The fuel pressure control valve 3.06 has the fuel pressure regulating function for lower fuel consumption. The fuel quantity that flows off goes into the fuel return. Operation with these regulating functions must be avoided if possible, or operate for some hours only. Decrease the rail pressure (see paragraph 2.3 Procedures and in 5562-1 Fuel pressure control valve 3.06).

If there is an overpressure in the HP fuel system (i.e. the fuel pressure control valve 3.06 becomes defective), the fuel overpressure safety valve 3.52 opens and the level switch LS3426A activates an alarm.

Faults in HP Fuel System

2.2 Causes

- The actuator is blocked.
- There is electrical interference (a cable coupling is defective, a cable is defective etc).

2.3 Procedures

2.3.1 One actuator is defective

- ⇒ Do a check of the control signals from the WECS-9520 and the electrical cables. If necessary, replace the electrical cables.
- ⇒ Make sure that the regulating linkage moves freely.
- ⇒ Install the spacer 3 (tool 94555A) to the toothed rack 2 in the center-line position on the fuel pump 1 that has the defective actuator 5 (see Fig. 'A').
- ⇒ Replace the defective actuator as soon as possible (see Regulating Linkage 5801-1 in the Maintenance Manual).
- You can install the spacer 4 (tool 94555) as an alternative to the spacers 3 in the position max. or min. (e.g. at full load). Fuel pressure regulation through the fuel pressure control valve 3.06 must be prevented if possible.
- ⇒ Turn the knurled screw on the fuel pressure control valve 3.06 (see 5562-1) fully counterclockwise.

A

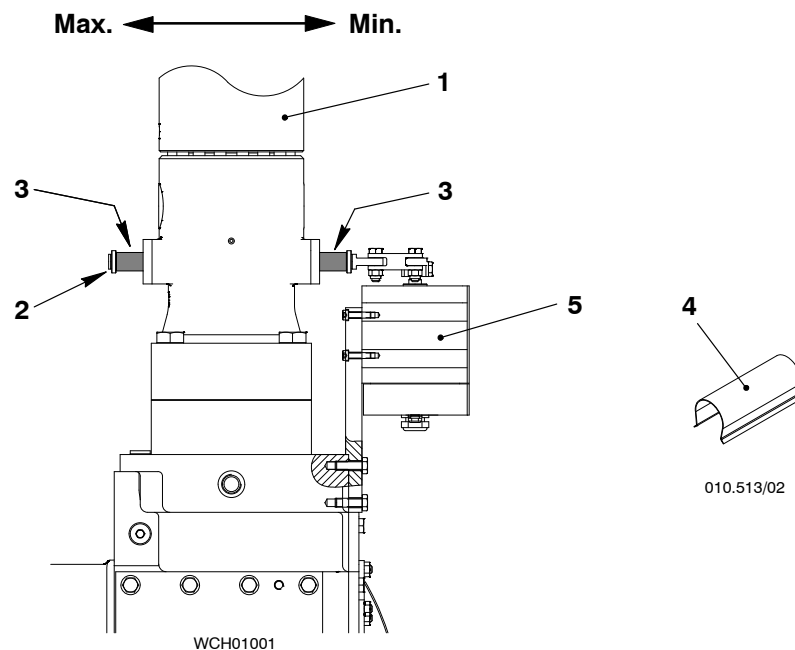

Key to Illustrations: 'A' Spacers for center-line and Max. / Min. positions

- | | |
|------------------------|-----------------------|
| 1 Fuel pump 3.14 | 4 Spacer (tool 94555) |
| 2 Toothed rack | 5 Actuator 3.21 |
| 3 Spacer (tool 94555A) | |

Faults in HP Fuel System

2.3.2 Three fuel pumps (5 and 6 cylinders), one pump blocked

For engines with 5 and 6 cylinders, see the table below for the applicable engine output ranges:

Tool	Position of toothed rack	Range of engine output
94555A	Center-line	approx. 20% to 80%
94555	Min.	approx. 0% to 40%
94555	Max.	approx. 40% to 100%

2.3.3 Three fuel pumps (7 cylinders), one pump blocked

For engines with 7 cylinders, see the table below for the applicable engine output ranges:

Tool	Position of toothed rack	Range of engine output
94555A	Center-line	approx. 10% to 90%
94555	Min.	approx. 0% to 70%
94555	Max.	approx. 30% to 100%

2.3.4 All actuators are defective

- ⇒ Install the spacers 3 and 4 (tools 94555A and 94555) to the toothed racks 2 in the center-line position and 'Max.' to all fuel pumps (see Fig. 'B').
- The spacers 3 and 4 can be installed in different positions for the applicable engine output.
- ⇒ Turn the knurled screw on the fuel pressure control valve 3.06 (see 5562-1) fully counterclockwise.

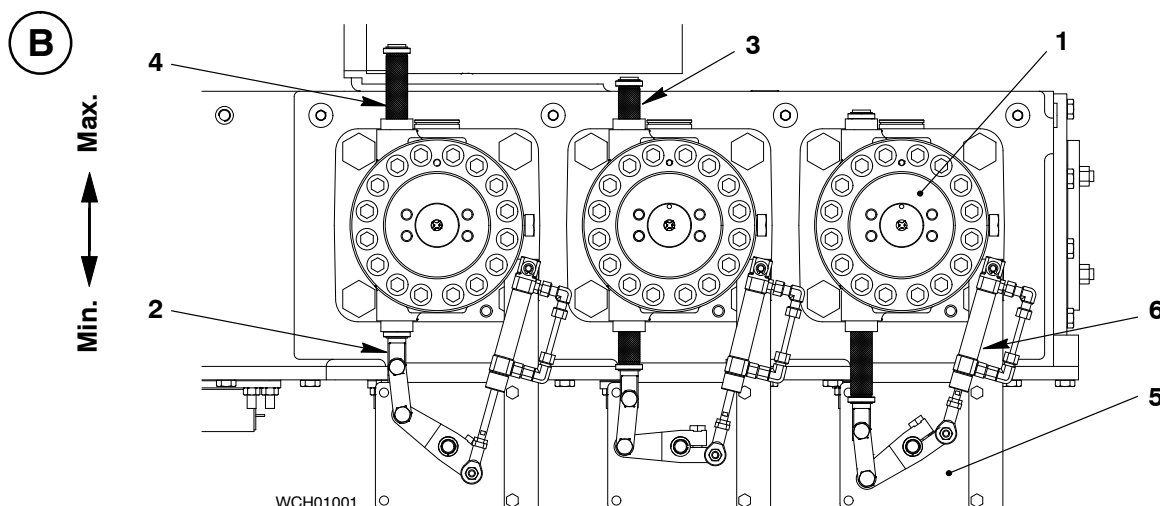

Key to Illustration: 'B' Spacer for position 'Min.' and 'Max.'

- | | |
|------------------------|-----------------------|
| 1 Fuel pump 3.14 | 4 Spacer (tool 94555) |
| 2 Toothed rack | 5 Actuator 3.21 |
| 3 Spacer (tool 94555A) | 6 Damper |

Faults in HP Fuel System

2.3.5 Three fuel pumps (5 and 6 cylinders), two pumps blocked

For engines with 5 and 6 cylinders, see the table below for the applicable engine output ranges:

Tool	Position of toothed rack	Range of engine output
94555A and 94555	Centerline and Max.	approx. 80%
94555A and 94555	Centerline and Min.	approx. 30%

2.3.6 Three fuel pumps (7 cylinders), all pumps blocked

Tool	Position of toothed rack	Range of engine output
94555A and 94555	2x Centerline and 1x Max.	approx. 70%
94555A and 94555	1x Centerline and 2x Max.	approx. 90%
94555A and 94555	1x Max. and 2x Min.	approx. 40%



Remark: With this emergency operation, fuel quantity regulation is not possible at higher fuel consumption. The fuel pressure control valve 3.06 gets control of the fuel pressure regulating function at lower fuel consumption. The fuel quantity that flows off goes into the fuel return.

Emergency operation with these regulating functions must only be for some hours.

If there is an overpressure in the HP fuel system (i.e. the fuel pressure control valve 3.06 becomes defective), the fuel overpressure safety valve 3.52 opens and the level switch LS3446A activates an alarm.

3. Defective injection control unit

3.1 Fault identification

- Alarm indication in WECS-9520 (remote control).
- The fuel injection is cut off automatically (Inj. CUT OFF) on the related cylinder, and a SLOW DOWN signal will be released.
- The injection control unit has a leak.
- The level switch LS3446A activates an alarm indication because of a leak at the injection pipes (see 8019-1 'Fuel leakage system').

3.2 Causes

- The fuel quantity sensor is defective.
- The fuel quantity piston 3.42 is against the stop (rail valve failure).
- The rail valve 3.76 is defective.
- There is a crack in the injection control unit.
- The injection control valve has seized.
- The fuel quantity piston is seized.
- An injection pipe is broken.

Faults in HP Fuel System

3.3 Procedures

3.3.1 Fuel quantity sensor



Remark: It is not necessary to stop the engine. Engine operation is also possible with a defective fuel quantity sensor.

Replace the defective fuel quantity sensor as follows:

- ⇒ Disconnect the electrical connection from the fuel quantity sensor 2 (see Fig. 'C').
- ⇒ Remove the screws 3 and washers.
- ⇒ Remove the fuel quantity sensor 2. Make sure that O-ring 4 stays in the housing 5.
- ⇒ Put oil on the O-ring 4.
- ⇒ Put the new fuel quantity sensor in position in the housing 5.
- ⇒ Put Never-Seez NSBT-8 on the threads of the screws 3.
- ⇒ Install the washers and screws 3. Torque the screws to 20 Nm.
- ⇒ Connect the electrical connection to the fuel quantity sensor 2. Make sure that the electrical connection is tight.

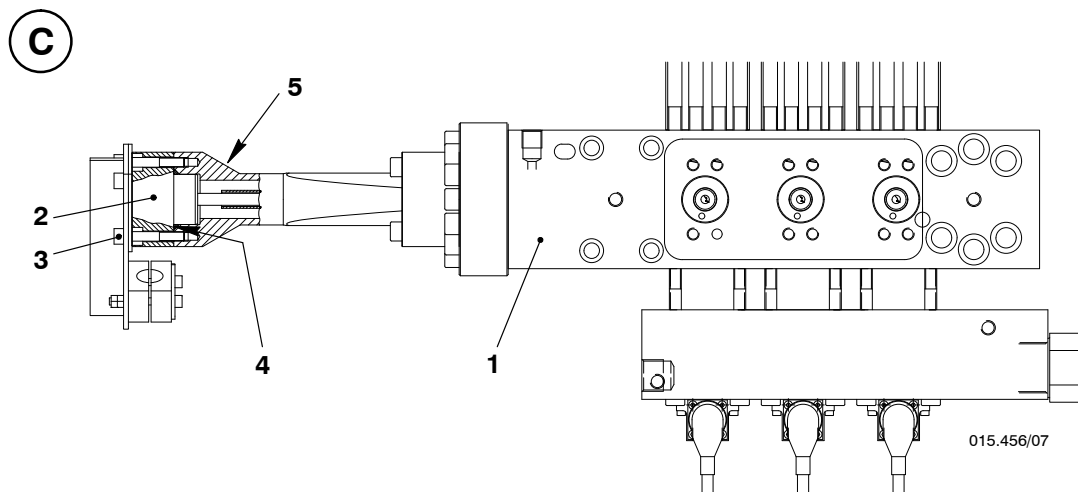

Key to Illustration: 'C' Injection control unit

- | | |
|-------------------------------|-----------|
| 1 Injection control unit 3.02 | 4 O-ring |
| 2 Fuel quantity sensor 3.03 | 5 Housing |
| 3 Screw | |

3.3.2 Fuel quantity piston

- ⇒ If the fuel quantity piston is against the stop, use the fuel shut-down pilot valve 3.08 (EM. STOP ZV7061S) to manually release the pressure in the fuel rail.



Remark: If a rail valve stays in the 'Inject' position, it is possible that this will cause a hydraulic lock. This can prevent movement of the fuel quantity piston. Usually, this not a seized piston.

- ⇒ If the procedure above is not satisfactory, see paragraph 3.3.4, Injection control unit.



Remark: You can find the fuel shut-down pilot valve 3.08 (EM. STOP ZV7061S) on the fuel pressure control valve 3.06 (see 5562-1, Fig. 'B').

Faults in HP Fuel System

3.3.3 Rail valve

Replace the defective rail valve as soon as possible.

- ⇒ Stop the engine.
- ⇒ Set to off the bearing oil pump.
- ⇒ Remove the screw plug 8 from the stop valve 7 (see Fig. 'D').
- ⇒ Carefully open the stop valve 7 to release all the pressure in the servo oil rail 2.
- ⇒ Disconnect the two electrical connections 6 from the rail valve 4.
- ⇒ Remove the four screws 5 and the rail valve 4 at the same time.
- ⇒ Make sure that the three O-rings are installed in the new rail valve and their surfaces are clean.
- ⇒ Apply Never-Seez NSBT-8 to the threads of the four screws 5.
- ⇒ Put the rail valve and screws 5 in position on the rail valve 4.

CHECK

Important! Make sure that the bores are aligned.

- ⇒ Torque the four screws 5 to 2.5 Nm (see Injection Control Unit 5564-1 in the Maintenance Manual).
- ⇒ Close the stop valve 7.
- ⇒ Install and tighten the screw plug 8.
- ⇒ Connect the electrical connections 6 to the rail valve. Make sure that the electrical connections are tight.

D

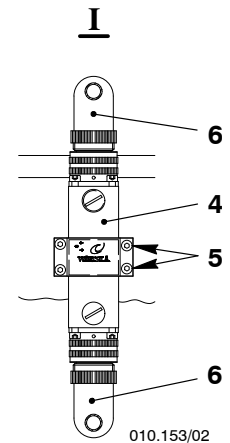
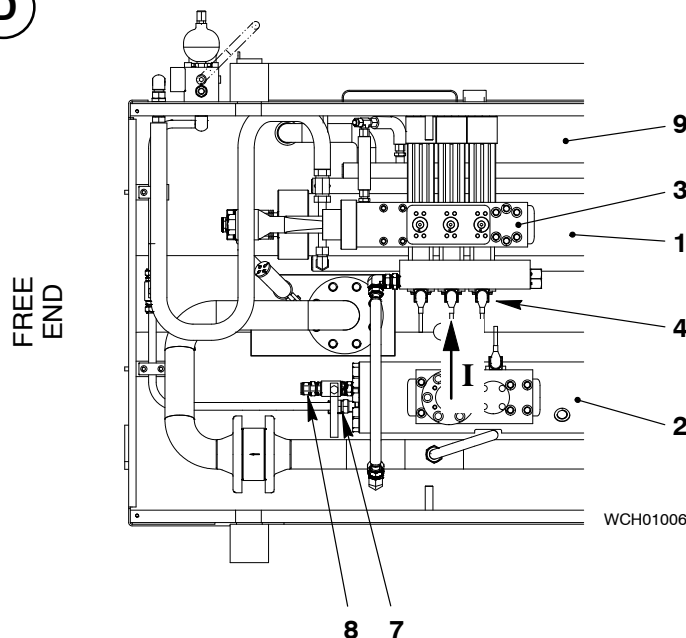

Key to Illustration: 'D' Servo oil and fuel rail

- | | |
|-------------------------------|-------------------|
| 1 Fuel rail 3.05 | 6 Cable |
| 2 Servo oil rail 4.11 | 7 Stop valve 3.40 |
| 3 Injection control unit 3.02 | 8 Screw plug |
| 4 Rail valve 3.76 | 9 Rail unit |
| 5 Screw | |

Faults in HP Fuel System

3.3.4 Injection control unit

The fuel injection must be cut out as an immediate procedure if:

- The injection control unit has cracks
- The injection control valve or fuel quantity piston is seized.

See 0510-1 paragraph 1, Cut out the injection.



Remark: With injection cut out (Inj. CUT OFF) you can only operate the engine at decreased load.

⇒ Replace the defective injection control unit as soon as possible (see 0510-1 'Restarting of the injection' and Injection Control Unit 5564-1 in the Maintenance Manual).

3.3.5 Injection pipe

⇒ If an injection pipe is broken, cut out the injection to the injection valves (see 0510-1 paragraph 1, Cut out the injection).

⇒ Replace the defective injection pipe as soon as possible (see 0510-1 'Replace the defective injection pipe' and Fuel Pressure Piping 8733-1 in the Maintenance Manual).

4. Defective fuel pressure control valve 3.06

4.1 Fault identification

- The engine load decreases or the engine stops.
- The fuel rail pressure is too low (alarm).
- The regulating shaft position is higher than usual or at maximum.
- You can hear whistling noises when the engine operates.

4.2 Causes

- The retaining pressure is set too low, i.e. the knurled screw 4 is not at the bottom stop (see Fig. 'E').
- The fuel pressure control valve 2 is defective.
- The fuel pressure control valve has opened or has a leak.



Remark: If the knurled screw 4 is at the bottom stop and fuel drains from the fuel pressure control valve, there is an indication of an internal leak.

Faults in HP Fuel System

4.3 Procedure

- ⇒ Turn the knurled screw 4 to the bottom stop (see Fig. 'E').
- ⇒ Overhaul or replace the defective fuel pressure control valve 2 as soon as possible.
- ⇒ Do a check of the oil supply to the fuel pressure control valve. Clean the filter in the inlet.



Attention! You must only replace the fuel pressure control valve when the engine has stopped.

The oil supply from the bearing oil system 7 and the fuel rail 3 must have no pressure.

- ⇒ Set to off the fuel booster pump 3.15 and the bearing oil pump.
- ⇒ Use the hand lever 6 on fuel shut-down pilot valve 5 to release the pressure in the fuel rail.

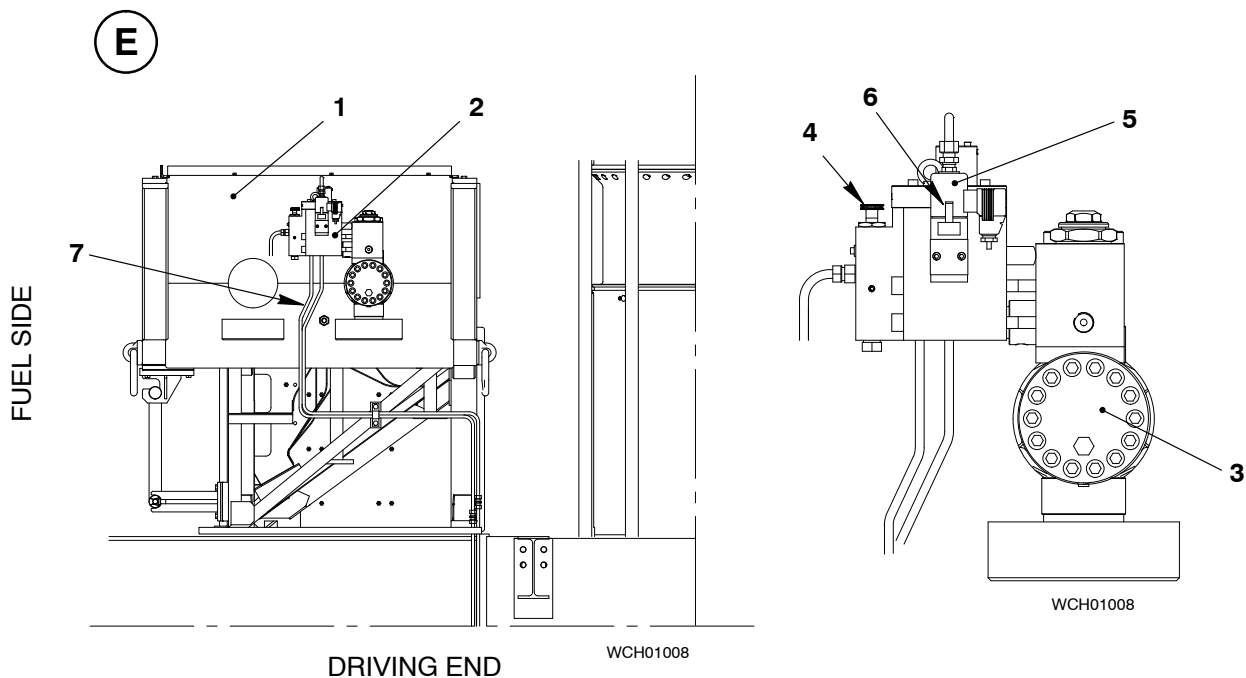

Key to Illustration: 'E'

- | | |
|------------------------------------|--------------------------------------|
| 1 Rail unit | 5 Fuel shut-down pilot valve 3.08 |
| 2 Fuel pressure control valve 3.06 | 6 Hand lever |
| 3 Fuel rail 3.05 | 7 Oil supply from bearing oil system |
| 4 Knurled screw | |

Operation during Unusual Conditions

Operation with Exhaust Valve Control Unit Cut Out

1. General

If an exhaust valve control unit, exhaust valve or a hydraulic pipe becomes defective, the defect must be repaired immediately.

If this not possible because the engine must stay in service, do the procedures given in paragraphs 2 and 3 on the related cylinder.

2. Emergency operation with exhaust valve closed

2.1 Exhaust valve control unit

If the exhaust valve is defective and there is a large difference between the closing or opening time, cut out the exhaust valve control unit.

The exhaust valve stays closed in the emergency procedure that follows:

- ⇒ Cut out the injection (see 0510-1 paragraph 1).
- ⇒ In the remote control, use the parameter Exv. A/M Cmd to manually close the exhaust valve control unit for the related cylinder (see 4002-3 paragraphs 1 and 1.1).



Attention! For safety, disconnect the electrical connections 7 from the rail valve 6 on the related cylinder (see Fig. 'A').

2.2 Procedure with exhaust valve control unit cut out

After the procedure above is completed, the engine can be put back in service.



Remark: With one or more exhaust valve control unit(s) cut out, you can only operate the engine at decreased load.

Read the data in 0500-1. The exhaust gas temperature downstream of the cylinders must not be more than the maximum limit of 515°C.

2.3 Start the exhaust valve control unit

Replace the defective exhaust valve control unit, or the hydraulic pipe as soon as possible as follows:

2.4 Replace the defective exhaust valve control unit or hydraulic pipe

- ⇒ Stop the engine.
- ⇒ Set to off the bearing oil pump.
- ⇒ Remove the screw plug 3 from the stop valve 2.
- ⇒ Carefully open the stop valve to release the pressure in the servo oil rail 1. Make sure that the servo oil rail has no pressure.
- ⇒ Loosen the screws 10 on the flange 8 to drain the hydraulic pipe 5 through the check bore 'CB' in the cover 9.
- ⇒ Replace the defective exhaust valve control unit or the hydraulic pipe (see 5612-1 and 8460-1 in the Maintenance Manual).
- ⇒ Close the stop valve 2.
- ⇒ Install the screw plug 3.
- ⇒ Set to on the bearing oil pump.
- ⇒ Cut in the injection (see 0510-1, paragraph 2).
- ⇒ In the remote control, use the parameter Exv. A/M Cmd to set the exhaust valve control unit on the related cylinder to Auto (see 4002-3 paragraphs 1 and 1.1).
- ⇒ Connect the electrical connections 7 to the rail valve 6.

CHECK

Do a visual check for leaks.

Operation with Exhaust Valve Control Unit Cut Out

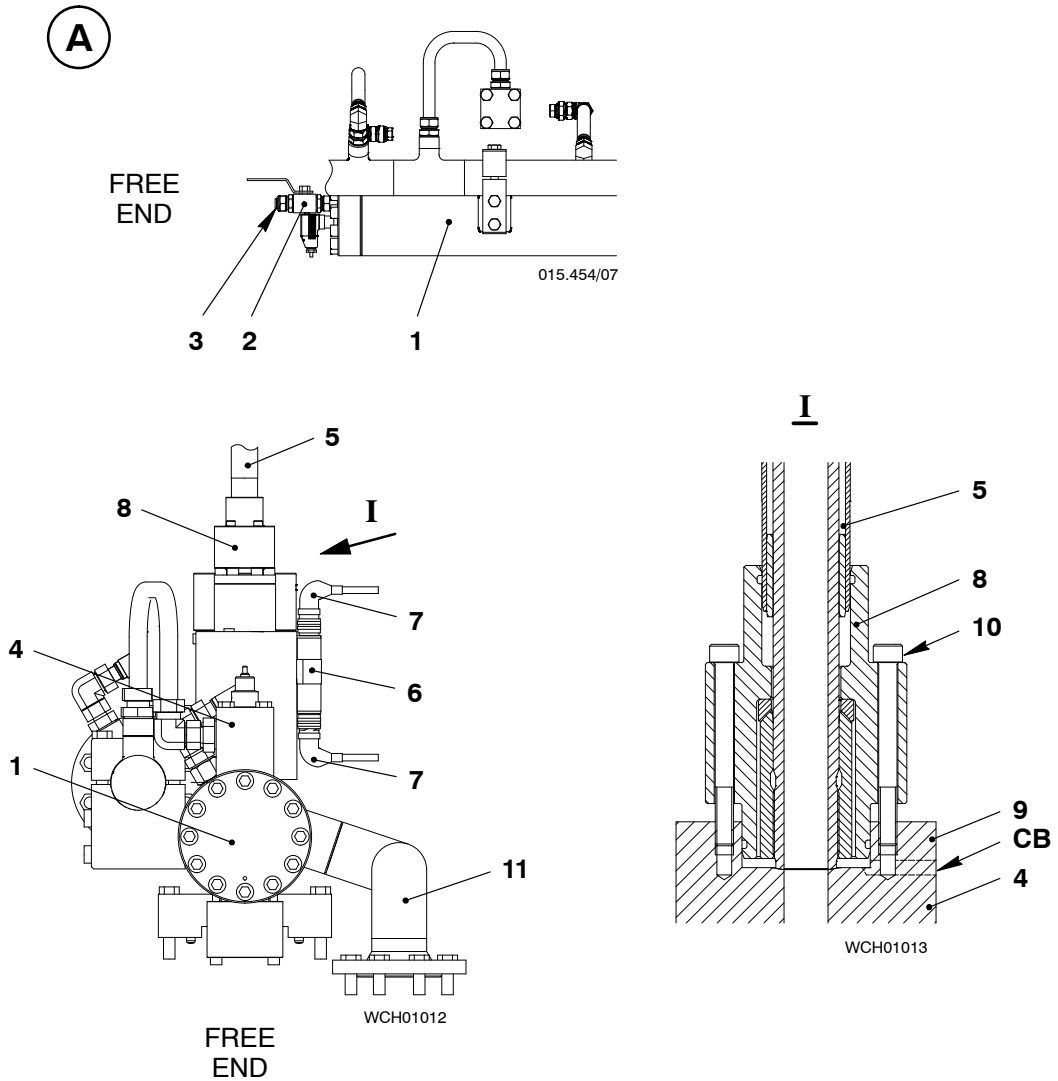

Key to Illustration: 'A' Servo oil rail / exhaust valve control unit

- | | |
|-----------------------------------|-------------------------------|
| 1 Servo oil rail 4.11 | 7 Electrical connections |
| 2 Stop valve 3.40 | 8 Flange |
| 3 Screw plug | 9 Cover |
| 4 Exhaust valve control unit 4.10 | 10 Screw |
| 5 Hydraulic pipe 4.66 | 11 Servo oil return pipe 4.63 |
| 6 Rail valve 4.76 | CB Check bore |

Operation with Exhaust Valve Control Unit Cut Out

3. Emergency procedure with exhaust valve opened

This emergency procedure is only necessary if there are water leakages into the combustion chamber (see also [0545-1](#)).

3.1 Exhaust valve out of service

- ⇒ Stop the engine.
- ⇒ Set to off the bearing oil pump.
- ⇒ Remove the damper 1 from the housing 2 (see Fig. 'B').
- ⇒ Close the air spring vent 4.08 in the control air supply **A**. The air in the air pipe to the exhaust valves is released and the exhaust valve stays open (see the Control Diagram [4003-2](#)).
- ⇒ Install the pressure element 3 (tool GF 94259) as shown in Fig. 'C'.
- ⇒ Disconnect the electrical connections from the rail valve of the related cylinder.
- ⇒ Open the air spring vent 4.08.
- ⇒ Set to on the bearing oil pump.
- ⇒ Disconnect the electrical connection from the start air pilot valve 4 on the starting valve.

After the procedure above is completed, the engine can be put back in service.



Remark: With one or more exhaust valve control unit(s) cut out, you can only operate the engine at decreased load.

Read the data in [0500-1](#). The exhaust gas temperature downstream of the cylinders must not be more than the maximum limit of 515°C.

3.2 Start the exhaust valve control unit

After completion of the emergency operation with the exhaust valve opened, you must do a check of the seating surfaces of the valve seat and head. The surfaces must be in perfect condition (no hard dirt particles). Seating surfaces with large particles must be overhauled. See 2751-3 and 2751-4 in the Maintenance Manual.

After the overhaul is completed, do the procedure that follows:

- ⇒ Set to off the bearing oil pump.
- ⇒ Close the air spring vent 4.08 in the control air supply **A**. The air in the air pipe to the exhaust valves is released and the exhaust valve stays open
- ⇒ Remove the pressure element 3 (tool GF 94259).
- ⇒ Install the damper 1 (see Fig. 'B').
- ⇒ In the remote control, select Inj. RUN to cut in the applicable cylinder (see [4002-3](#) paragraphs 1 and 1.1).
- ⇒ Open the air spring vent 4.08.
- ⇒ Set to on the bearing oil pump.
- ⇒ Connect the electrical connections to the rail valve.
- ⇒ Connect the electrical connection to the start air pilot valve 4 on the starting valve.

Operation with Exhaust Valve Control Unit Cut Out

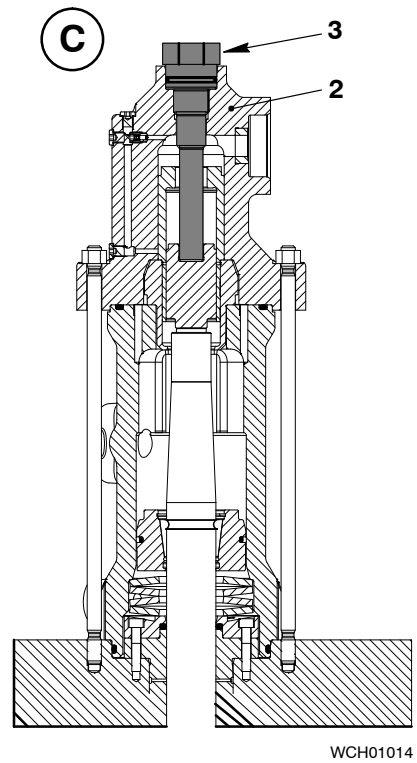
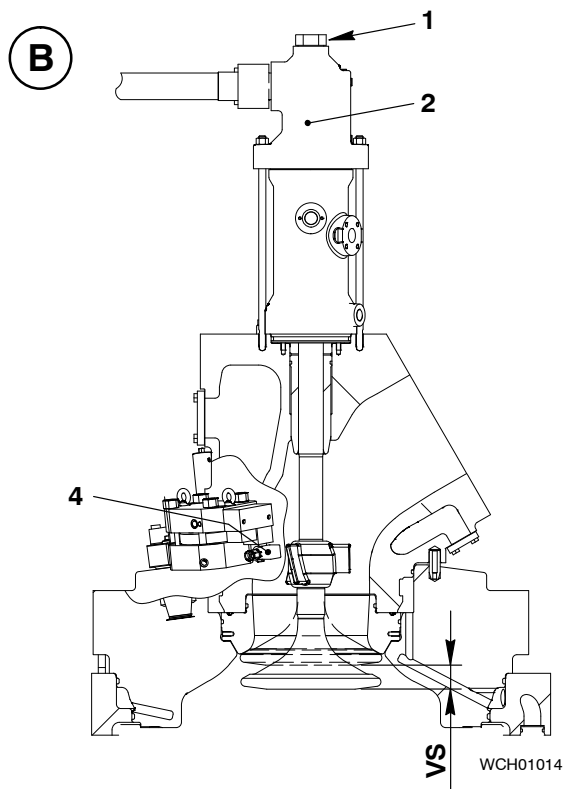
**Key to Illustrations: 'B' and 'C'**

- 1 Damper
- 2 Upper housing
- 3 Pressure element (tool GF 94259)
- 4 Start air pilot valve (ZV7241-47C)

VS Maximum exhaust valve stroke

Operation during Unusual Conditions

Faults in Servo Oil System

1. Defective automatic filter

1.1 Identification

An alarm indication shows in the ship alarm system and in the control box of the automatic filter (XS2053A).

The differential pressure is too high.

Flushing intervals are shorter.

1.2 Causes

The filter elements are clogged.

The control or power supply is defective.

The system oil parameters are more than the limits given in 0750-1 paragraph 2.2 Alert limits for selected system oil parameters.

1.3 Procedures

- ⇒ If the automatic filter is clogged, select bypass. The engine stays in operation.
- ⇒ Clean the clogged filter elements manually.
- ⇒ Find the cause of the clogged automatic filter.
- ⇒ Repair the defective automatic filter (see the supplier documentation for the automatic filter).
- ⇒ Do a check of the condition of the system oil (see 0750-1 paragraph 2.4 Oil samples).
- ⇒ If no flushing cycle is released, find the cause (i.e. no control air, the motor turns, the position switch or the pneumatic flushing valve is defective).

2. Defective servo oil pump

2.1 Identification

The flow sensors FS2061A – FS2063A indicate that a pump is defective, i.e. an alarm is activated in the alarm and monitoring system ('Servo oil pump n. flow').

2.2 Causes

The servo oil pump is blocked, the carrier at overload protection has broken (see Servo Oil Pump 5551-1).

The actuators are defective CV7221C – CV7222C.

There is a problem with the control current (the cable coupling is defective).

2.3 Procedure

If a pump becomes defective, the engine can continue to operate through the full load range.

- ⇒ Replace the defective servo oil pump as soon as possible. See the data in:
 - 8016-1, paragraph 6.2 Pressure release and drain
 - The Maintenance Manual 5552-1 Supply Unit.



Attention! Do not operate the the engine for long periods if one servo oil pump is defective. If the other pump becomes defective, the engine cannot operate.

Faults in Servo Oil System

3. Defective exhaust valve control unit**3.1 Identification**

An alarm indication shows in the WECS-9520 (remote control 'Exh. valve late/not opening').

The fuel injection is cut out automatically (Inj. CUT OFF) on the related cylinder, and a slow down signal will be released.

The level switch LS3444A activates an alarm indication because of leakages at the hydraulic pipes to the exhaust valves (see 8016-1 paragraph 5, Servo oil leakage system).

3.2 Causes

The rail valve is defective.

The piston or slide rod in the exhaust valve control unit cannot move.

A hydraulic pipe to the exhaust valve is broken.

3.3 Procedures**3.3.1 Rail valve**

Replace the defective rail valve as soon as possible.

- ⇒ Stop the engine.
- ⇒ Set to off the bearing oil pump.
- ⇒ Remove the screw plug 2 from the stop valve 1 (see Fig. 'A').
- ⇒ Carefully open the stop valve 1 to release the pressure in the servo oil rail 3. Make sure that the servo oil rail 3 has no pressure.
- ⇒ Disconnect the electrical connections 9 from the rail valve 7.
- ⇒ Remove the four screws 8, then remove the rail valve 7.
- ⇒ Make sure that the three O-rings are in the new rail valve and their surfaces are clean.
- ⇒ Attach the rail valve 1 to the exhaust valve control unit 4 with the four screws 8.

CHECK

Important! Make sure that the bore positions are correctly aligned.

- ⇒ Torque the four screws 8 to 4.0 Nm.
- ⇒ Close the stop valve 1.
- ⇒ Install and tighten the screw plug 2.
- ⇒ Connect the electrical connections 9 to the rail valve 7. Make sure that the electrical connections are tight.

Faults in Servo Oil System

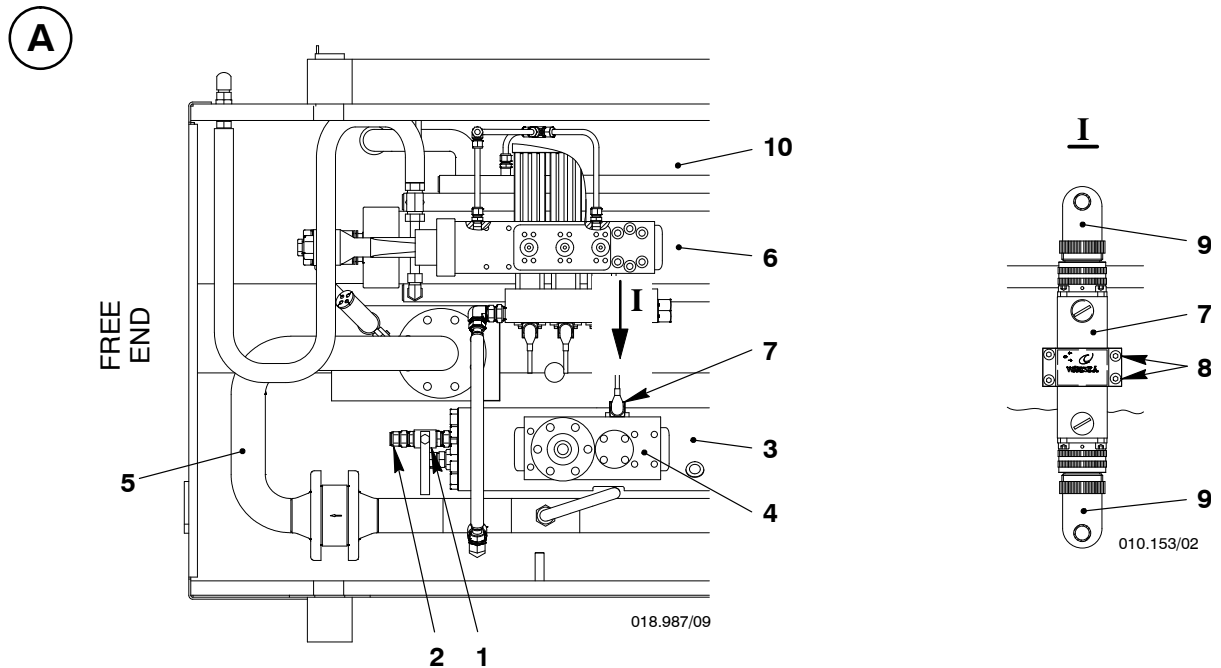

Key to Illustration: 'A' Servo oil rail at free end

- | | |
|-----------------------------------|-------------------------|
| 1 Stop valve 3.40 | 6 Fuel rail 3.05 |
| 2 Screw plug | 7 Rail valve 4.76 |
| 3 Servo oil rail 4.11 | 8 Screws |
| 4 Exhaust valve control unit 4.10 | 9 Electrical connection |
| 5 Servo oil return pipe 4.63 | 10 Rail unit |

3.3.2 Defective exhaust valve control unit

The exhaust valve control unit must be shut off as an immediate procedure if:

- The piston or slide rod in the exhaust valve control unit is seized.

See 0520-1 paragraph 2, Emergency operation with exhaust valve closed.



Remark: With one or more exhaust valve control unit(s) cut out, you can operate the engine only at decreased load.

⇒ Replace the defective exhaust valve control unit as soon as possible. See the data in:

- 0520-1 paragraph 3.2, Start the exhaust valve control unit
- The Maintenance Manual 5612-1.

3.3.3 Hydraulic pipe to exhaust valve

⇒ If a hydraulic pipe to the exhaust valve is defective, cut out the injection of the related cylinder. See 0510-1 paragraph 1, Cut out the injection.

⇒ Replace the defective hydraulic pipe as soon as possible. See the data in:

- 0520-1 paragraph 2.4, Replace the defective exhaust valve control unit or hydraulic pipe
- The Maintenance Manual, 8460-1.

Intentionally blank

Operation during Unusual Conditions

Operation without Crosshead Lubricating Oil Pump

1. General

If the crosshead lubricating oil pump becomes defective, the crosshead bearing oil system operates at the lower pressure of the main bearing oil.

At decreased load, the engine can continue to operate for a short time until the crosshead bearing oil pump is repaired or replaced.



Attention!

- The engine power must not be more than 40%. See [0820-1](#) 'Crosshead bearing oil pressure decreases'.
- Do not operate the the engine for long periods. The booster pump must be repaired or replaced as soon as possible and set to on.

Intentionally blank

Operation during Unusual Conditions

Operation with Running Gear Partially or Totally Removed

1. General

If the engine must operate after a defect in the running gear (of a cylinder), which cannot be immediately repaired, do the related procedures that follow in paragraph 2 or paragraph 3.

2. Piston removed

2.1 Breakdown examples

- The piston is cracked or has a leak.
- There is damage to the piston and/or cylinder liner.
- There is damage to the piston rod gland and/or piston rod.

2.2 Procedure

The exhaust valve stays closed during the emergency operation that follows:

- ⇒ Cut out the injection (see 0510-1 paragraph 1, Cut out the injection).
- ⇒ Cut out the exhaust valve control unit (see 0520-1 paragraph 2, Emergency operation with exhaust valve closed).
- ⇒ Remove the control air pipe 7 from elbow 6 (Fig. 'A').
- ⇒ Remove the elbow 6 from the starting air pipe 5.
- ⇒ Install the blank flange 8 (tool 94831).
- ⇒ Disconnect the electrical connection 11 from the from the start air pilot valve on the starting valve.
- ⇒ Install the cover plate 9 (tool 94345D) in place of the piston rod gland.
- ⇒ Install the cover and lifting plate 10 (tool 94324) to the crosshead.
- ⇒ If necessary, close the cooling water supply and the return pipe of the related cylinder.



Remark: You can operate the engine only at decreased load.

Read the data in 0500-1. The exhaust gas temperature downstream of the cylinders must not be more than the maximum limit of 515°C.

Operation with Running Gear Partially or Totally Removed

3. Piston, crosshead and connecting rod removed

3.1 Breakdown examples

- The crosshead or guide shoes are defective.
- The connecting rod bearing is damaged.
- The crosshead pin or on the connecting rod are defective.

3.2 Procedure

The exhaust valve stays closed during the emergency operation that follows:

- ⇒ Cut out the injection (see 0510-1 paragraph 1, Cut out the injection).
- ⇒ Cut out the exhaust valve control unit (see 0520-1 paragraph 2, Emergency operation with exhaust valve closed).
- ⇒ Remove the control air pipe 7 from elbow 6 (Fig. 'A').
- ⇒ Remove the elbow 6 from the starting air pipe 5.
- ⇒ Install the blank flange 8 (tool 94831).
- ⇒ Disconnect the electrical connection 11 from the from the start air pilot valve on the starting valve.
- ⇒ Install the cover plate 9 (tool 94345D) in place of the piston rod gland .
- ⇒ If necessary, close the cooling water feed and the return pipe of the related cylinder.
- ⇒ Blank off the oil supply for piston cooling at 'OS'.
- ⇒ Blank off the oil supply for the crosshead lubrication outside the engine.
- ⇒ Remove the toggle lever 3.



Remark: You can operate the engine only at decreased load.

Read the data in 0500-1. The exhaust gas temperature downstream of the cylinders must not be more than the maximum limit of 515°C.

Operation with Running Gear Partially or Totally Removed

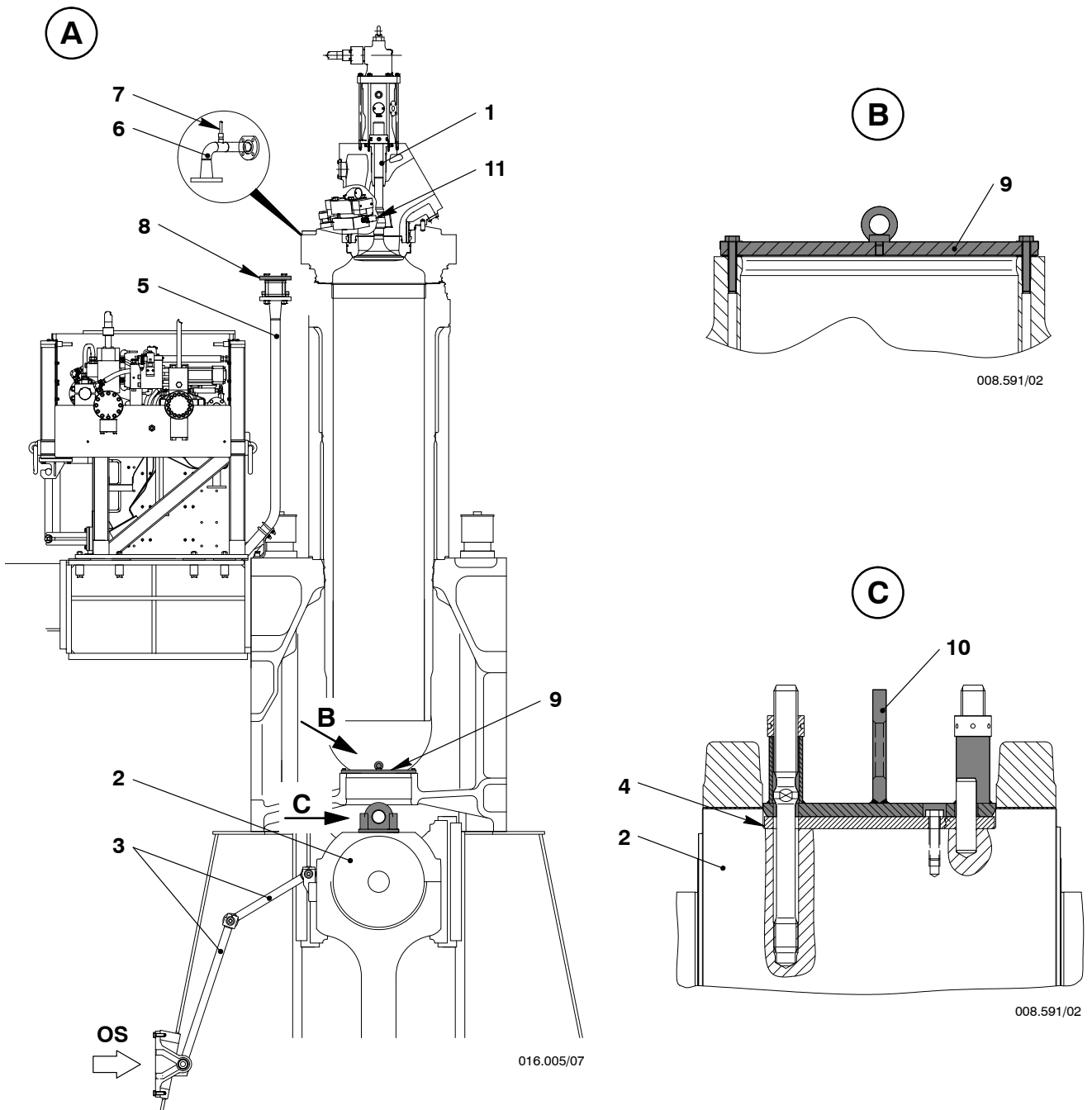

Key to Illustrations:

- 'A' Seal off the cylinder
- 'B' Cover plate for piston rod gland
- 'C' Seal off the crosshead

- | | |
|---------------------|-----------------------------------------|
| 1 Exhaust valve | 8 Blank flange (tool 94831) |
| 2 Crosshead | 9 Cover plate (tool 94345D) |
| 3 Toggle lever | 10 Cover and lifting plate (tool 94324) |
| 4 Compression shim | 11 Electrical connection |
| 5 Starting air pipe | |
| 6 Elbow | |
| 7 Control air pipe | |
- OS Oil supply

Intentionally blank

Operation during Unusual Conditions

Operation with Water Leakage into the Combustion Chamber

1. General

If there is water leakage into the combustion chamber (e.g. a crack in the cylinder cover or liner) the related part must be replaced immediately.

If this not possible because the engine must stay in service, do the procedures given in paragraph 2 on the related the cylinder.

2. Procedure

⇒ Close the valves to the cooling water inlet and outlet from the related cylinder (disconnect from the cooling system) and drain the cooling water from the drain pipe.

⇒ See [0510-1](#) Operation with injection cut out.

⇒ See Operation with Exhaust Valve Control Unit Cut Out (see [0520-1](#) paragraph 3, Emergency procedure with exhaust valve opened).



Remark: When the cooling system of the related cylinder is disconnected, there is a risk that compression heat will cause the combustion chamber to become too hot. Thus, the exhaust valve must be open to prevent damage to components.

After the procedure above is completed, the engine cannot operate at full load.

Read the data in [0500-1](#). The exhaust gas temperature downstream of the cylinders must not be more than the maximum limit of 515°C.

Do not operate the the engine for long periods. The defective cylinder cover or cylinder liner must be replaced as soon as possible.

After this emergency operation is completed, see [0520-1](#) paragraph 3.2 for the procedures to start the exhaust valve control unit.

Intentionally blank

Operation during Unusual Conditions

Overpressure in the Combustion Chamber

1. General

It is possible that overpressure can occur in the combustion chamber. Overpressure in the combustion chamber (i.e. too much fuel, oil, water or a permanently closed exhaust valve etc.) can cause the relief (safety) valve to open and / or the cylinder cover to lift.



Attention! Investigate the cause(s) of the overpressure immediately.

2. Measures

Remove the cylinder cover and the water guide jacket for a visual inspection of the combustion chamber (see 2708-1 in the Maintenance Manual).

Do the checks that follow:

- ⇒ Use the correct round bar to make sure that the nuts of the elastic studs 5 are tight.
- ⇒ Put the hydraulic tensioning device 94215 in position as given in 2708-2 Maintenance Manual.
- ⇒ Carefully operate the hydraulic tensioning device. Increase the pressure until the nuts become loose.
 - If the pressure is almost the same as the nominal tightening pressure, the elastic studs are not overstressed and can be used again.
 - If the nuts become loose at a pressure of less than 20% of the nominal tightening pressure, replace the elastic studs as given in the Maintenance Manual 2751-1.
- ⇒ Make sure that:
 - The gasket 6 is serviceable.
 - The surfaces 'AF' on the cylinder cover 1 and liner 2 are in perfect condition.
 - The O-rings 7, 8, and 9 are replaced with new items.
 - If a relief valve is fitted (depending on Class requirements), do a check in accordance with 2745-1 in the Maintenance Manual.
 - On the crankshaft, the two marks 'MA' on all cylinders are in line. If the marks are not in line, the crank has turned.



Attention! If the crank has turned, contact Wartsila Services Switzerland Ltd. immediately.



Remark: If the engine must be operational as soon as possible and the problem cannot be rectified within reasonable time, see the instructions give in:

- Operation with Running Gear Partially or Totally Removed [0540-1](#)
- Operation with Injection Cut Out (One or More Cylinders) [0510-1](#) or other related instructions.

Overpressure in the Combustion Chamber

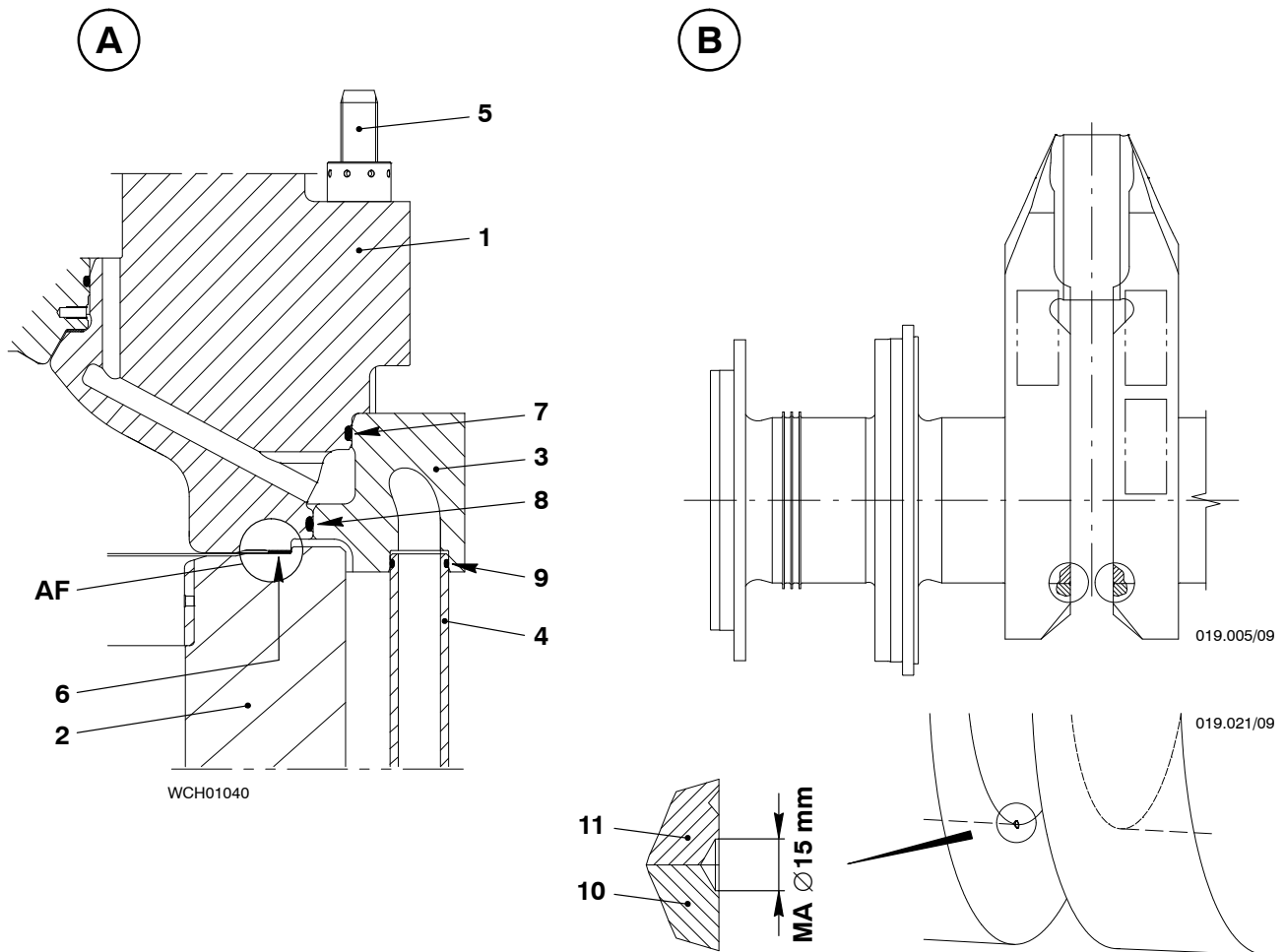
**Key to Illustrations:**

- | | | | |
|---|---------------------------------|----|-----------------|
| 1 | Cylinder cover | 8 | O-ring |
| 2 | Cylinder liner | 9 | O-ring |
| 3 | Water guide jacket (upper part) | 10 | Crank |
| 4 | Transition tube | 11 | Shaft journal |
| 5 | Elastic stud | AF | Seating surface |
| 6 | Gasket | MA | Mark (recess) |
| 7 | O-ring | | |

3. Cylinder cover

See the Maintenance Manual for:

- Removal and Fitting of the Cylinder Cover and Water Guide Jacket 2708-1
- Loosening and Tensioning of the Cylinder Cover Elastic Studs 2708-2

Operation during Unusual Conditions

Scavenge Air Cooler Out of Service / Failure of Auxiliary Blowers

1. Scavenge air cooler out of service

When a scavenge air cooler (SAC) is defective, water can go into the scavenge air receiver. The water then goes out through the drain pipe into the float / solenoid switch unit of the SAC drain. The related level switch activates an alarm.

Because seawater is also used to cool the scavenge air, there is a risk that a leak can cause bad corrosion of the air flaps, etc in the receiver.



Remark: If you see water flow through the sight glass of the SAC drain during engine standstill (and water is pumped), do a check for faults as soon as possible.

If there is a fault in the SAC, we recommend that you do the procedure that follows:

- ⇒ Replace the defective SAC with the spare as soon as possible.
- ⇒ Shut down and drain the defective SAC (this is only possible with a dual-system of coolers and turbochargers).
- ⇒ Seal the cooling water supply and return pipes of the defective SAC.
- ⇒ Open the vent and drain valves. The vent and drain valves must stay open.
- Leakage water that goes into the receiver flows away through the drain pipes of the SAC and water separator into the collection pipe.
- During operation in this mode, the scavenge air temperature and exhaust gas temperature will increase.
- You can only load the engine so that the scavenge air temperature (measured downstream of the SAC) is not more than the usual limit at service output. You must continuously and carefully monitor the scavenge air temperature.
- If the scavenge air temperature increase is too high, the engine speed must be decreased (maximum permitted scavenge air temperature downstream of the cooler, see Alarms and Safeguards [0250-2](#)).



Remark: You can operate the engine only at approximately 25% load.

In an emergency, you can seal the defective SAC pipes (see Maintenance Manual 6606-1 'Locating and sealing of leaking cooler tubes in service').

2. Defective auxiliary blowers

If one of the auxiliary blowers becomes defective, you can start and operate the engine. At partial load, there will be more exhaust smoke.

If the two auxiliary blowers become defective, the engine cannot start.

Intentionally blank

Operation during Unusual Conditions

Defective Remote Control

1. General

If a fault occurs in the remote control, which prevents engine control from the control room, you can operate the engine from the local control panel.

The data are given in the groups that follow:

- Starting [0230-1](#)
- Maneuvering [0260-1](#)
- Shutting Down [0310-1](#)
- Procedures after Engine Stop [0320-1](#)
- [4003-1](#) 'Engine local control'
- Local Control Panel [4618-1](#)



Attention! You must operate the engine during unusual conditions only when necessary. You must not leave the maneuvering stand. You must monitor the engine speed frequently to make sure that procedures are immediately done if large differences in engine speed occur.

Intentionally blank

Operation during Unusual Conditions

Defect in Speed Control System

1. General

Defects in the speed control system must be repaired as soon as possible (see the documentation of the manufacturer). If this is not possible, you can control the engine at the local control panel.

If the fuel command signal from the speed control system is missing during engine operation, the speed control system will continue to operate. However, the last known fuel command will be used and you will hear an alarm.

The data are given in the groups that follow:

- Starting [0230-1](#)
- Maneuvering [0260-1](#)
- Engine Shutdown [0310-1](#)
- Procedures after Engine Stop [0320-1](#)
- [4003-1](#) 'Engine local control'
- Local Control Panel [4618-1](#)



Attention! You must operate the engine during unusual conditions only when necessary. You must not leave the maneuvering stand. You must monitor the engine speed frequently to make sure that procedures are immediately done if large differences in engine speed occur.

Intentionally blank

Operation during Unusual Conditions

Turbocharger Out of Service

1. General

If a turbocharger becomes defective, you must shut down the engine as quickly as possible to prevent damage.

If repair or replacement of a turbocharger is not be immediately possible, the engine can operate in Emergency Operation at decreased load after the procedures below are completed.

In Emergency Operation, you must only operate the engine for as long as necessary (see 0500-1 paragraph 2, Decreased power output).

The loads (outputs) given are guidance values, which are related to the condition of the engine. It is possible that these values will be decreased.

2. Defective condition 1

On engines that have two turbochargers, one turbocharger is defective.

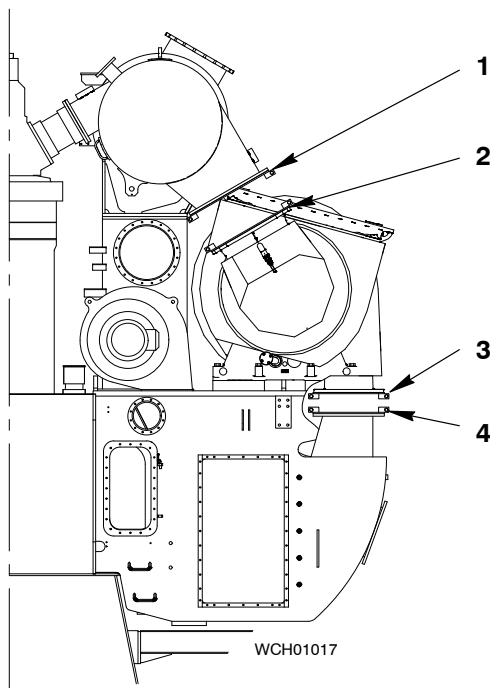

Output related to CMCR:

Approximately 50%

Procedure

- ⇒ Remove the expansion joint between the defective turbocharger and the exhaust manifold
- ⇒ Install the blind flanges 1 and 2.
- ⇒ Remove the expansion joint between the air outlet of the defective turbocharger and the diffuser.
- ⇒ Install the blind flanges 3 and 4 (install the blind flange 3 only if there is a suction pipe).
- ⇒ Lock the rotor of the defective turbocharger as given in the turbocharger manual.



Remark: Do not let the scavenge air pressure, turbocharger speed and firing pressures be more than the values given for usual operation.

Turbocharger Out of Service

3. Defective condition 2

Defective turbocharger on engines without an exhaust bypass pipe.

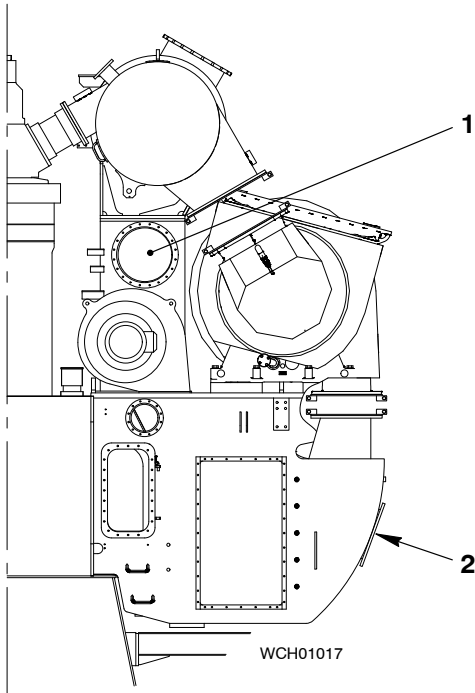
**Output related to CMCR:**

Approximately 10% to 15% is related to the output of the auxiliary blowers.

Procedure

- ⇒ Lock the rotors of the defective turbochargers as given in the turbocharger manual.
- ⇒ Open the cover 2.
- ⇒ Set the auxiliary blower to on.
- ⇒ If an auxiliary blower becomes defective, install the cover 1 on the defective blower side.



Remark: The exhaust gas temperature must not be higher than at usual operation. Thick, black exhaust smoke must be prevented.

Turbocharger Out of Service

4. Defective condition 3

Failure of turbocharger on engines with only one turbocharger and exhaust bypass pipe.

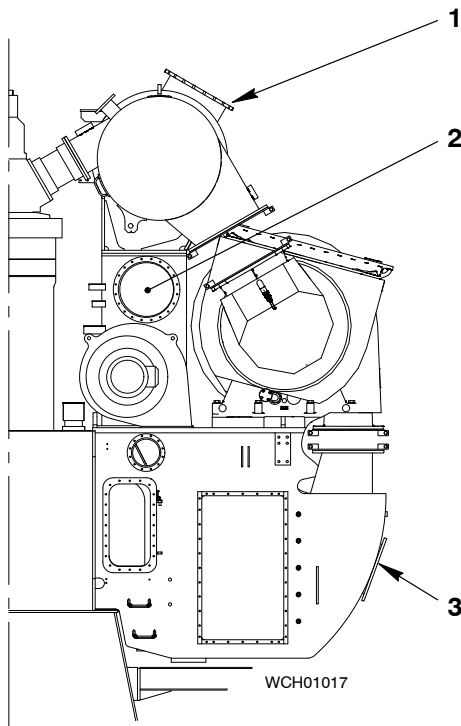
**Output relative to CMCR:**

Approximately 25% to 30% is related to the output of the auxiliary blowers.

Procedure

- ⇒ Lock the rotor of the defective turbocharger as given in the turbocharger manual.
- ⇒ Open cover 3 on the air duct.
- ⇒ Remove the cover 1 from the bypass pipe.
- ⇒ Set the auxiliary blower to on.
- If an auxiliary blower becomes defective, install the cover 2 to the defective blower side.



Remark: The exhaust gas temperature must not be higher than at usual operation. Thick, black exhaust smoke must be prevented.

Intentionally blank

Special Procedures before and after Operation

Procedures before Starting after a Long Shutdown Period or an Overhaul

1. General

If the engine was shut down for some days, you must do the same procedures before starting as those given in [0110-1](#) Preparation before Taking into Service.

2. Special procedures



Remark: The numbers (e.g. 4.11) refer to items shown in the control diagrams [4003-2](#) and [4003-3](#).

⇒ Do a check of the engine control as given in [4003-1](#) paragraph 4, Engine Control System.

⇒ If bearings or parts of the running gear were replaced or removed (for checks), do a check of the the lubricating oil supply at the usual oil pressure (see Operating Data Sheet [0250-1](#)). Do a visual check through the open running gear doors to see if there is sufficient oil flow from all bearing locations.

During the operation period, it is recommended that you monitor the parts for unusual heat. You monitor the parts as follows:

⇒ Stop and start the engine for short intervals (see [0210-1](#) paragraph 9, Temperature).

⇒ Compare the temperatures of the newest parts with those that were installed before.

⇒ Stop and start the engine for longer intervals.

⇒ Compare the temperature again as given above.

● For data about running-in new pistons, piston rings and cylinder liners, see [0410-1](#) paragraph 1.2, Running in.

⇒ After the servo oil rail 4.11 is drained, make sure that the stop valve 3.40 is closed and the screw plug is installed and tight (see [8016-1](#) paragraph 6.2, Pressure release and drain).

⇒ Make sure that the scavenge air and exhaust gas can flow freely.

⇒ If the cooling water for the scavenge air cooler was drained, fill and bleed the system.

⇒ Make sure that the drains in the exhaust gas manifold and on the exhaust gas pipe are closed.

⇒ Make an analysis of the lubricating oil quality after a long shutdown period (some months), see [0750-1](#) Lubricating Oils.

Intentionally blank

Special Procedures before and after Operation

Procedures before Putting Out of Service for a Long Period

1. General

If the engine is put out of service for an extended period, make sure that you know the correct precautions to protect the engine from corrosion. There are two conditions as follows:

Condition 1:

- A period of some weeks with (less) crew on board.

Condition 2:

- A period of some months without a crew on board.



Remark: If the engine is to be stopped for a long period, it must be thoroughly cleaned and preserved on the inside and the outside (ask for the preserving instructions from Wärtsilä Services Switzerland Ltd.).

2. Condition 1

2.1 Procedures and checks



Remark: It is recommended to operate the engine on diesel oil as an alternative to heavy fuel oil for some time before shutting it down (see Change-over from Diesel Oil to Heavy Fuel Oil and Back [0270-1](#)).



Remark: The numbers (e.g. 2.10) refer to items shown in the control diagrams [4003-2](#) and [4003-3](#).

- ⇒ Close the stop valves on the starting air bottles.
- ⇒ Turn the handwheel 2.10 on the shut-off valve for starting air 2.03 to the position CLOSED.
- ⇒ Open the vent valves 2.21 and 2.27.
- ⇒ Make sure that the pressure gauges show zero pressure.
- ⇒ Engage the turning gear.
- The water and oil pumps must operate for a minimum of 20 minutes after the engine has stopped. This is to make sure that the temperature of the cooled engine parts become as stable as possible.
- ⇒ Open the indicator valves on the cylinder covers.
- Lubrication starts automatically during the slow-down of the engine (speed is more than 8%).
- ⇒ When the engine has stopped, cut out the fuel pumps, see [5556-2](#) paragraph 1 and paragraph 2.
- ⇒ Close the stop valves on the fuel tanks.
- ⇒ Open the drain valves of the exhaust gas manifold and on the exhaust gas pipe to drain the condensate.
- ⇒ Close the drain valves of the exhaust gas manifold and on the exhaust gas pipe.
- ⇒ Put a cover (e.g. a tarpaulin) on the exhaust gas manifold and the turbocharger silencer to make an airtight seal. This will prevent air flow through the engine and thus condensation.

Procedures before Putting Out of Service for a Long Period

- ⇒ For the scavenge air coolers, see the recommended procedures in the documentation of the manufacturer. If this is not available, we recommend that the coolers are completely drained or the cooling water pump operated daily for approximately 30 minutes (with the flow quantity control valves in the same position as for usual operation conditions).
- ⇒ Keep cylinder cooling water approximately at room temperature. Monitor the temperature for a risk of frost.
- ⇒ Repair all the damage and leaks found during the operation period before and the checks made after shut-down.
- ⇒ Do all scheduled overhauls and obey the general guidelines for maintenance (see Maintenance Manual 0011-1 and 0012-1).
- ⇒ Where the auxiliary engines and boilers are also put out of operation and there is risk of frost, completely drain all of the cooling systems (in such conditions, protect the drained systems from corrosion).
- ⇒ In the power supply box E85, use the circuit breaker to set the WECS-9520 to off.
- ⇒ Set to off the control box for the automatic filter.
- ⇒ Within 48 hours after you have put the engine out of service, do the checks that follow:
- ⇒ Open cover on rail unit and look for signs of condensation and corrosion.
- ⇒ Remove the inspection cover from supply unit and look for signs of condensation and corrosion on the internal housing, camshaft, cams and roller.

2.2 Procedures and checks

Do the procedures that follow each week:

- ⇒ With the indicator valves open, use the turning gear to turn the engine until one of the pistons is at 60° before or after TDC (look on the flywheel). Cylinder lubricating oil can then flow directly into the piston ring pack.
- ⇒ In the field MANUAL LUBRICATION ON CYL. in the operator interface, select the related cylinder number.



Remark: The lubricating oil pump and the servo oil service pump must operate (see Prepare the Cylinder Lubricating System 0140-1).

- ⇒ Use the turning gear to turn the engine two full turns to apply the cylinder lubricating oil on to the cylinder liner wall.
- ⇒ The recommended intervals are:
 - Weekly in dry climates
 - Daily in damp climates.
- ⇒ Stop the engine each time in a different position.
- ⇒ Open the cover on the rail unit and look for signs of condensation and corrosion.
- ⇒ Remove the inspection cover from supply unit and look for signs of condensation and corrosion on the internal housing, camshaft, cams and roller.
- ⇒ If there are signs of corrosion, carefully clean the applicable parts.
- ⇒ Apply an anti-corrosion oil to give protection.
- ⇒ Decrease the lubrication intervals.
- ⇒ Apply oil as a spray to the dry parts.

Operating Media

Diesel Engine Fuels

Overview

1.	General	1/12
2.	Heavy fuel oil	2/12
3.	Data about heavy fuel oil specifications	5/12
4.	Distillate fuel specifications	9/12
5.	Data about distillate fuel specifications	9/12
6.	Bio derived products and fatty acids methyl esters	12/12
7.	Fuel additives	12/12

1. General

Almost all mineral residual and distillate and some renewable fuels can be burned in a diesel engine if applicable procedures are done. But, the quality of the fuel will have an effect on the frequency of overhauls and the work necessary to prepare the fuel. It is the primary economic considerations that according to the type, size and speed of the engine, and its application gives the fuel quality margins.

Gas oils and diesel oils (distillates) can be used in all Wärtsilä engines with some limits. Wärtsilä 2-stroke diesel engines are designed to operate on up to 700 mm²/s (cSt) at 50° viscosity heavy fuel oil (ISO 8217:2010 RMK 700 grade) if sufficient fuel heating and treatment is done. When fuels with a very low sulphur content are used, operators must be careful when running-in new piston rings and cylinder liners.

Heavy fuel oil must be treated in an applicable fuel treatment plant.

When bunkering, it is possible that the fuel suppliers will report only some of the values given in the Quality Specifications. Frequently, only the density and maximum viscosity is given. This makes the analysis of a fuel difficult, thus it is important to get a full certificate of analysis with each bunker.

The supplier must guarantee the stability of the fuel, i.e. resistance to the formation of sludge. Also, the fuel must not have a corrosive effect on the injection equipment and must not contain used lubricating oil or chemical waste.

If possible, oils from different bunkers must not be mixed because there is a risk that the fuels will have different compositions (e.g. this can cause fouling of filters or too much sludge, which will overload the fuel preparation equipment). Fresh bunkers must always be put into empty tanks and not on top of old bunkers.

Diesel Engine Fuels

2. Heavy fuel oil

Diesel engine fuels include many different petroleum products from gas oil to Heavy Fuel Oil (HFO). Gas oil is made from crude oil by distillation and processing. HFO is the remaining material after distillation of the crude oil. To get the necessary viscosity, the material is mixed with lighter, less viscous components. Modern refineries also apply a secondary conversion process, such as viscosity breaking (visbreaking) and catalytic cracking to get a higher yield of lighter products. The remaining products are mixed to get HFO.

Viscosity is usually used to identify diesel engine fuels. The viscosity is shown in mm^2/s , referred to as centistokes (cSt) and measured at 50°C . The fuels are classified in accordance with ISO 8217 and the latest revision is the fourth edition dated 15 June 2010.

Viscosity itself is not a quality criterion. To make an analysis of the fuel quality (to make sure that the fuel is applicable for use in a diesel engine), refer to the properties such as those given in the Table 1.

To make an estimate of the ignition properties of a distillate diesel fuel, the CETANE number (standardized engine test) or the CETANE index (calculation) were used. The ignition and combustion properties are very important for medium and high-speed engines. For low-speed diesel engines, the ignition properties are not very important.



Remark: Some very poor fuels that are not frequently found can have important ignition properties.

Very good supervision, engine maintenance and fuel treatment equipment is necessary when fuel with properties near the maximum limits are used. Fuel preparation that is not sufficient and poor quality fuels cause overhauls to be more frequent and thus, an increase in the cost of maintenance.

The values in the column Bunker limit (ISO 8217:2010 RMK700) show the minimum quality of heavy fuel as bunkered, i.e. as supplied to the ship/installation. Good operation results come from commercially available fuels that are in the ISO 8217 limits. But the use of fuel with metal, ash and carbon contents and a lower density can have a positive effect on overhaul periods. These effects can improve combustion and exhaust gas composition as well as a decrease in wear.

The fuel as bunkered must be processed before it goes into the engine. It is recommended that you refer to the related specifications of Winterthur Gas & Diesel Ltd. for the design of the fuel treatment plant. The minimum centrifuge capacity is $1.2 \times \text{CMCR} \times \text{BSFC} / 1000$ (litres/hour), which is has a relation to 0.21 l/kW . The fuel treatment must remove sludge and decrease catalyst fines and water to the recommended engine inlet limits.

In ISO 8217, foreign substances such as used oil or chemical waste must not be added to the fuel. This is because of the hazards to the crew, machines and the environment. Tests that are done for unwanted substances as acids, solvents and monomers with titrimetric, infrared and chromatographic methods, are recommended. This is because of the damage these substances can cause to fuel treatment, fuel injection equipment, pistons, rings, liners, and exhaust valves and seats. Turbocharger, exhaust system and boiler contamination can also occur because of poor fuel quality.

Diesel Engine Fuels

The engine inlet fuel quality uses the latest ISO 8217:2010 specification. Bunkers that comply with ISO 8217:2005 can be used until the latest ISO specification is fully released. In such conditions, the higher values for carbon residue and vanadium can be satisfactory.

It is very important that the fuel is fit for purpose in the related engine application.

Table 1: Fuel Specifications

Parameter	Unit	Bunker Limit	Test Method	Necessary Fuel Quality at Engine Inlet
Kinematic viscosity at 50°C	mm ² /s [cSt]	Maximum 700	ISO 3104	13 to 17 ²⁾
Density at 15°C	kg/m ³	Maximum 1010 ³⁾	ISO 3675/12185	Maximum 1010
CCAI	–	870	Calculated	870
Sulphur ⁴⁾	m/m [%]	Statutory specifications	ISO 8754/14596	Maximum 3.5
Flash point	°C	Minimum 60.0	ISO 2719	Minimum 60.0
Hydrogen sulphide ⁵⁾	mg/kg	Maximum 2.00	IP 570	Maximum 2.00
Acid number	mg KOH/g	Maximum 2.5	ASTM D 664	Maximum 2.5
Total sediment aged	m/m [%]	Maximum 0.10	ISO 10307-2	Maximum 0.10
Carbon residue: micro	m/m [%]	Maximum 20.00	ISO 10370	Maximum 20.00
Pour point (upper) ⁶⁾	°C	Maximum 30	ISO 3016	Maximum 30
Water	v/v [%]	Maximum 0.50	ISO 3733	Maximum 0.20
Ash	m/m [%]	Maximum 0,150	ISO 6245	Maximum 0,150
Vanadium	mg/kg [ppm]	Maximum 450	ISO 14597/ IP501/470	Maximum 450
Sodium	mg/kg [ppm]	100	IP501/IP470	Maximum 30
Aluminum plus Silicon	mg/kg [ppm]	Maximum 60	ISO 10478/ IP501/470	Maximum 15
Used lubricating oils (ULO) may not be present: Calcium and zinc Calcium and phosphorous	mg/kg	ULO shows if: Ca>30 and Zn>15 or Ca>30 and P>15	IP501 or IP470 IP500	Do not use if: Ca>30 and Zn>15 or Ca>30 and P>15
Winterthur Gas & Diesel Ltd. fuel specifications and quality limits at the engine inlet related to ISO 8217:2012 ¹⁾				

Diesel Engine Fuels

The notes that follow are related to the data in Table 1:

1mm²/s=1cSt (Centistoke)

- *1) You can get ISO standards from the ISO Central Secretariat, Geneva, Switzerland (www.iso.ch).
- *2) For W-X engines the fuel viscosity at the fuel pump inlet can be in the range of between 10 mm²/s (cSt) and 20 mm²/s (cSt). When the engine operates on HFO, Winterthur Gas & Diesel Ltd. recommends a fuel viscosity at the fuel pump inlet in the range of between 13 mm²/s (cSt) and 17 mm²/s (cSt).
- *3) The maximum limit is 991kg/m³ if the fuel treatment plant cannot remove water from high-density fuel.
- *4) ISO 8217:2010, RMK700. Note that lower sulphur limits can apply and are related to statutory specifications and sulphur limits not given in ISO 8217:2010.
- *5) The hydrogen sulphide limit is applicable from 1 July 2012.
- *6) Purchasers must make sure that the pour point is sufficient for the equipment on board, specially for operation in cold climates.



Remark: For data about the parameters given in the table above, see paragraph 3.1 to paragraph 3.12.



Damage Hazard: Hydrogen Sulphide (H₂S) is a very toxic gas and exposure to high concentrations is dangerous and can kill you. Be careful when tanks or fuel lines are opened because there can be H₂S vapor. At low concentrations H₂S smells almost the same as bad eggs. You cannot sense H₂S at moderate concentrations. H₂S will cause nausea and dizziness.

Diesel Engine Fuels

3. Data about Heave Fuel Oil Specifications

3.1 Viscosity

The recommended viscosity range upstream of the engine is between 13 mm²/s (cSt) and 17 mm²/s (cSt). You get the necessary temperature for a given nominal viscosity from the data in Fig. 1 below:

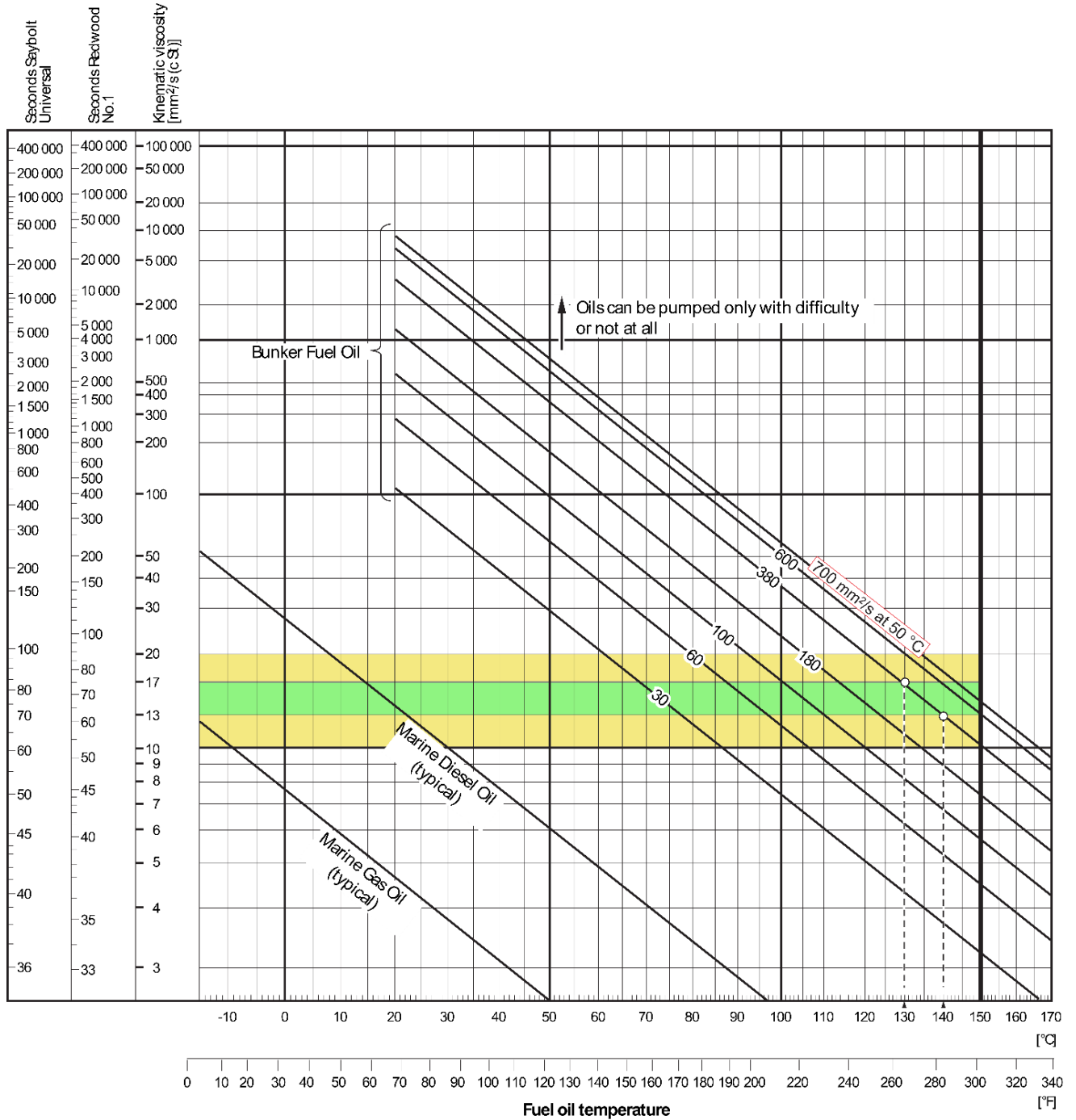

- 1. Required viscosity range for RTA and older engines
- 2. Recommended viscosity range for RT-flex and W-X engines
- Required viscosity range for RT-flex and W-X engines

Example:
To get the recommended viscosity upstream of the fuel pumps, the fuel of 380 mm²/s [cSt] at 50°C must be heated to between 130°C and 140°C.

WCH03126

Diesel Engine Fuels

The maximum permitted viscosity of the fuel that can be used in an installation is related to the heating and fuel preparation facilities available. The flow rate and the temperature of the fuel that flows through the centrifuges must be adjusted in relation to the viscosity to get good separation. Do not heat the fuel to more than 150°C to get the recommended viscosity at the engine inlet. This is because the fuel can start to decompose, get contamination and be dangerous as it is possible that the temperature will be higher than the flash point.

3.2 Density

The composition of the fuel gives the density. A high density shows a high aromatic content. It is not always possible to use conventional methods to measure the density at 15°C. Thus, the measurement is made at a higher temperature and then converted and adjusted to the reference temperature. Most bunkers are to the ISO 8217:2010 RMG specification, which has a maximum density of 991.0 kg/m³. Applicable fuel preparation equipment, which can be adjusted for a fuel density greater than 991.0 kg/m³, must be available on board if high density fuels are used.

3.3 CCAI (Calculated Carbon Aromaticity Index)

The ignition and combustion properties of the fuel in a diesel engine are related to the specific engine design, load profile and fuel properties.

The CCAI is a calculated quantity of the ignition properties or ignition interval of the fuel related to the viscosity and density. The CCAI has no effect on the combustion properties. The CCAI limit is useful to measure fuels with unusual density-viscosity relations.

More tests are available to find ignition and combustion properties and these can be helpful to examine the performance of fuels.

3.4 Sulphur

Sulphur limits are not specified in ISO 8217:2010 because statutory specifications put a limit on this value. The maximum sulphur level that can be used in Wärtsilä 2-stroke engines is 4.5% m/m.

The alkalinity (base number (BN)) of the cylinder lubricating oil must be selected in relation to the sulphur level of the fuel in use. The engine can operate for short periods (some hours) with a cylinder lubricating oil that has an incorrect BN, but a longer operation time must be prevented.

Indications for the selection of the BN of the lubricating oil in relation to the sulphur content of the fuel are found in:

- [0410-1](#) Running-in of New Cylinder Liners and Piston Rings
- [0750-1](#) Lubricating Oils, paragraph 3.

3.5 Flash point

The flash point is an important safety and fire hazard parameter for diesel fuels. Fuel is always a fire hazard because there can be flammable vapors above the remaining fuel in the tanks. There must be caution on ships when the remaining fuel is heated to above the flash point to help with the filter process and injection.

3.6 Hydrogen sulphide



Danger: Hydrogen Sulphide (H₂S) is a very toxic gas and exposure to high concentrations is dangerous and can kill you. Be careful when tanks or fuel lines are opened because there can be H₂S vapor. At low concentrations H₂S smells almost the same as bad eggs. You cannot sense H₂S at moderate concentrations. H₂S will cause nausea and dizziness.

Diesel Engine Fuels

3.7 Acid number

Fuels with high acid numbers have caused damage to fuel injection systems. Most fuels have a low acid number, which is not dangerous, but an acid number above 2.5 mg KOH/g, can cause problems. Some naphthenic fuels can have an acid number of more than 2.5 mg KOH/g, but still be permitted. Only a full laboratory analysis can find the strong acid number.

3.8 Sediment, carbon residue, asphaltenes

High quantities of sediment, carbon and asphaltenes decrease the ignition and combustion quality of the fuel and increase wear and damage to engine components. Asphaltenes also have an effect on the stability of mixed fuels and can cause too much sludge in the separators and filters. If the mixed fuel is not stable, particles can collect on the bottom of the tank.

To keep risks to a minimum, make sure that bunkers from different suppliers and sources are not mixed in the storage tanks on board. Also be careful when HFO is mixed on board to decrease the viscosity. Paraffinic distillate, when added to an HFO of low stability reserve, can cause the asphaltenes to collect, which causes heavy sludge.

HFO can contain up to 14% asphaltenes and will not cause ignition and combustion problems in 2-stroke engines if the fuel preparation equipment is adjusted correctly.

3.9 Pour point

The operation temperature of the fuel must be kept between approximately 5°C to 10°C above the pour point to make sure that the fuel can flow easily.

3.10 Water

The separator and the correct configuration of drains in the settling and service tanks is used to decrease the water quantity in the fuel. A complete removal of water is highly recommended to decrease the quantity of hydrophilic cat fines and sodium in the fuel. Sodium is not a natural oil component, but diesel engine fuel often has sea water contamination, which has sodium. 1.0% sea water in the fuel is related to 100 ppm sodium.

To get a good separation effect, the flow rate and temperature of the fuel must be adjusted in relation to the viscosity. For high-viscosity fuels the separation temperature must be increased, although the flow rate must be decreased in relation to the nominal capacity of the separator. For the recommended data to operate the separator, refer to the instruction manual.

3.11 Ash and trace metals

Fuels with a low content of ash, vanadium, sodium, aluminium, silicon, calcium, phosphorous and zinc are recommended. These materials can increase mechanical wear, high-temperature corrosion and particles in the turbocharger, exhaust system and boilers.

3.11.1 Vanadium and sodium

Sodium compounds decrease the melting point of vanadium oxide and sulphate salts, specially when the vanadium to sodium ratio is 3:1. High sodium quantities (as well as lithium and potassium) at the engine inlet can damage the turbocharger, exhaust system and boilers. Ash modifiers can correct the effect of high-temperature corrosion and particles.

Diesel Engine Fuels

3.11.2 Aluminium and silicon

Aluminum (Al) and silicon (Si) in the fuel are an indication of catalytic fines (cat fines). These are particles of hard oxides (round particles of material almost the same as porcelain) which cause high abrasive wear to pistons, piston rings and cylinder liners. Cat fines are used as a catalyst in some processes in petroleum refining and can be found in diesel engine fuels. The most dangerous cat fines are between 10 microns and 20 microns.

Cat fines are attracted to water droplets and are very difficult to remove from the fuel. With correct treatment in the fuel separator, the aluminium and silicon content of 60 ppm (mg/kg) can be decreased to 15 ppm (mg/kg), which is thought to be satisfactory. For satisfactory separation, a fuel temperature as close as possible to 98°C is recommended. If there are more than 40 ppm cat fines in the bunkered fuel, a decreased flow rate in the separator is recommended. Also, the instructions of the equipment manufacturer must be obeyed.

Cat fines can collect in the sediment of the fuel tank from other bunkers. During bad weather conditions, the movement of the ship mixes the sediment into the fuel. Thus, it is better to think that all fuels contain cat fines, although it is possible that a fuel analysis can show a different result. This makes continuous and satisfactory separation very important.



Remark: The Al+Si limit in the new ISO 8217:2010 specification is decreased to 60 mg/kg for the RMG and RMK grades.

3.12 Used lubricating oil and chemical waste

Used lubricating oils and chemical waste must not be mixed into the fuel pool. If used lubricating oil is mixed in, fuel is not stable because the base oil is very paraffinic and can cause too much sludge. Most used lubricating oil is from the crankcase, thus sufficiently large quantities of calcium, zinc, phosphorous and other additives and wear metals can cause contamination. The limits in ISO 8217: 2010 and the Winterthur Gas & Diesel Ltd. specification make sure that no used lubricating oil is in the fuel. This is related to the limits of the test methods used to find the levels of these metals, which can occur naturally in the fuel.

Chemical waste must not be added to the fuel. There were some examples of polymers, styrene and other chemical substances found in fuel. These materials can cause the fuel to become too thick, to become almost solid and to block filters. They can also cause damage to fuel injection systems and cause fuel pump plungers and injectors to stop.

Diesel Engine Fuels

4. Distillate fuel requirements



Remark: For data about the parameters given in the table above, see paragraph 5.1 to paragraph 5.12.

Parameter	Unit	Bunker Limit	Test Method	Necessary Fuel Quality at the Engine Inlet
Kinematic viscosity at 40°C	mm ² /s [cSt]	Maximum 11.0 Minimum 2.0	ISO 3104	Minimum 2.0 Not related to temperature
Density at 15°C	kg/m ³	Maximum 900.0	ISO 3675/12185	Maximum 900.0
Cetane index	–	Minimum 35	ISO 4264	Minimum 35
Sulphur ¹⁾	m/m [%]	2.0	ISO 8754/14596	Maximum 2.0
Flash point	°C	Minimum 60.0	ISO 2719	Minimum 60.0
Hydrogen sulphide ²⁾	mg/kg	Maximum 2.00	IP 570	Maximum 2.00
Acid number	mg KOH/g	Maximum 0.50	ASTM D 664	Maximum 0.50
Total sediment by hot filtration	m/m [%]	Maximum 0.10	ISO 10307-1	Maximum 0.10
Oxidation stability	g/m ³	Maximum 25	ISO 12205	Maximum 25
Carbon residue: micro method on 10% volume distillation residue (for grades DMX, DMA and DMZ)	m/m %	Maximum 0.30	ISO 10370	–
Carbon residue: micro method (grade DMB)	m/m %	Maximum 0.30	ISO 10370	Maximum 0.30
Pour point (upper) winter ³⁾	°C	Maximum –6	ISO 3016	Maximum 0
Pour point (upper) summer	°C	Maximum 6	ISO 3016	Maximum 6
Water	v/v [%]	Maximum 0.30	ISO 3733	Maximum 0.20
Ash	m/m [%]	Maximum 0,010	ISO 6245	Maximum 0.010
Lubricity, corrected wear scar diameter (wsd 1.4) at 60°C	µm	Maximum 520	–	–
Winterthur Gas & Diesel Ltd. distillate fuel specifications and quality limits at the engine inlet related to ISO 8217:2012				

The notes that follow relate to data in Table 2:

1mm²/s=1cSt (Centistoke)

- *1) The purchaser must specify the maximum sulphur content in accordance with the usual statutory specifications.
- *2) The hydrogen sulphide limit is applicable from 1 July 2012.
- *3) Purchasers must make sure that the pour point is sufficient for the equipment on board, specially for operation in cold climates.

Diesel Engine Fuels

Distillate fuels are used more in 2-stroke engines to meet area specified emission standards. They are easier to operate than residual fuel, but caution is necessary for some problems. See Service Bulletin RT-82: Distillate Fuel Use.

ISO 8217: 2010 specifies DMX, DMA, DMZ and DMB categories. The Wärtsilä engine inlet specification is based on the DMB grade which is the highest viscosity grade. The DMX grade must not be bunkered as the viscosity could be below 2.0 mm²/s and the flash point could be below 60°C.

5. Data about Distillate Fuel Specifications

5.1 Viscosity

The recommended viscosity range on residual fuel upstream of the engine inlet is 13 mm²/s (cSt) to 17 mm²/s (cSt). But, because distillate fuel does not have such a high viscosity, a minimum viscosity of 2.0 mm²/s (cSt) at the fuel pump inlet is necessary.

Operators must be careful during the change-over procedure from distillate to residual fuel and back to make sure of problem free operation. See the Service document: Engine operation on MDO/MGO, change-over from HFO to MDO/MGO and the Service Bulletin RT-82: Distillate Fuel Use.

In some conditions, it is possible that you cannot get the minimum viscosity of 2.0 mm²/s (cSt) at the fuel pump inlet. In such conditions, a fuel cooling system will be necessary to make sure that the inlet to the fuel pumps has the minimum viscosity.

5.2 Density

The composition of the fuel gives the distillate density and a high density indicates a high aromatic quantity.

5.3 Cetane Index

The ignition and combustion properties of a distillate fuel in a diesel engine is related to the specific engine design, load profile and fuel properties. The Cetane Index is a calculated quantity of the ignition properties or ignition interval of the fuel related to the distillation and density. The density and the temperature when 10%, 50% and 90% of the fuel is distilled, gives the Cetane Index. This has no effect on the fuel combustion properties.

5.4 Sulphur

Sulphur limits are specified in ISO 8217:2010 for distillate fuels, but statutory specifications must be obeyed. The alkalinity (BN) of the cylinder lubricating oil must be selected in relation to the sulphur content of the fuel in use.

The engine can operate for short periods (some hours) with a cylinder lubricating oil that has an incorrect BN, but a longer operation time must be prevented.

Indications for the selection of the BN of lubricating oil in relation to the sulphur content of the fuel are found in:

- [0410-1](#) Running-in New Cylinder Liners and Piston Rings
- [0750-1](#) Lubricating Oils, paragraph 3.

5.5 Flash point

The flash point is an important safety and fire hazard parameter for diesel fuels. Fuel is always a fire hazard because there can be flammable vapors above the remaining fuel in the tanks.

Diesel Engine Fuels

5.6 Hydrogen sulphide



Injury Hazard: Hydrogen Sulphide (H_2S) is a very toxic gas and exposure to high concentrations is dangerous and can kill you. Be careful when tanks or fuel lines are opened because there can be H_2S vapor. At low concentrations H_2S smells almost the same as bad eggs. You cannot sense H_2S at moderate concentrations. H_2S will cause nausea and dizziness.

5.7 Acid number

Fuels with high acid numbers have caused damage to fuel injection systems. Most fuels have a low acid number, which is not dangerous, but an acid number above 2.5 mg KOH/g, can cause problems.

5.8 Sediment

High quantities of sediment decrease the ignition and combustion quality of the fuel and increase wear and damage to engine components. High sediment quantities can cause filters to block, or frequent discharge from filter systems that have automatic cleaning. For more data about mixtures, see paragraph 3.8 in the HFO section.

5.9 Pour point

The operation temperature of the fuel must be kept between approximately $5^{\circ}C$ to $10^{\circ}C$ above the pour point to make sure that the fuel is pumped easily. It is possible that in extremely cold conditions, there could be problems for distillate fuel.

5.10 Water

The quantity of water in distillate fuel can be decreased as follows:

- Let the fuel settle in the service tanks
- Use the centrifuge to remove water from the fuel.

5.11 Ash and trace metals

Distillates must have low quantities of ash, vanadium, sodium, aluminium, silicon, calcium, phosphorous and zinc related to residual fuels. High quantities of these materials increase mechanical wear, high-temperature corrosion and particles in the turbocharger, exhaust system and the boilers.

5.12 Used lubricating oil and other contaminants

Lubricating oils and chemical waste must not be mixed into the distillate fuel pool. Lubricating oil can cause water to stay because of the large quantity of detergent. Additive materials such as calcium, magnesium, zinc and phosphorous could increase the ash content to more than that given in the specification.

Chemical waste must not be added to distillate fuel. There were some examples of chemical waste substances found in fuel. These materials can cause the fuel to become too thick, to become almost solid and to block filters. They can also cause damage to fuel injection systems and cause fuel pump plungers and injectors to stop.

Diesel Engine Fuels

6. Bio-derived products and Fatty Acid Methyl Esters (FAME)

Such components can be found in diesel engine fuels and can cause a decrease of greenhouse gases and SOx emissions. Most bio-fuel components in the diesel pool are Fatty Acid Methyl Esters (FAME), which come from a special chemical treatment of natural plant oils. These components are mandatory in automotive and agricultural diesel in some countries. FAME is specified in ISO 14214 and ASTM D 6751.

FAME has good ignition properties and very good lubrication and environmental properties, but the other properties that follow about FAME are well known:

- Possible oxidation and thus long term storage problems.
- A chemical force that causes fuel and water to combine
- Microbial growth can appear in the fuel
- Unsatisfactory low temperature properties.
- FAME material particles can appear on exposed surfaces and filter elements.

Where FAME is used as a fuel, make sure that the on board storage, handling, treatment, service and machinery systems can be used with such a product.

7. Fuel Additives

Usually, fuel additives are not necessary to make sure of the satisfactory operation of fuels that obey the ISO 8217:2010 standard. But some operators can use specified additives to change the effect of some fuel properties. Wärtsilä Services Switzerland Ltd. can make an analysis of such additives and supply a No Objection Letter for specified additives if they are in the limits of internal specifications.



Remark: Winterthur Gas & Diesel Ltd. and Wärtsilä Services, Switzerland Ltd. do not accept liability or responsibility for the performance or potential damage caused by the use of such additives.

Operating Media

Fuel Treatment, Fuel Oil System

1. General

Heavy fuel oils (HFO), as they are supplied today for use in diesel engines must have careful treatment, which makes the installation of applicable plant necessary. The best procedure to remove solid particles and water from fuel is to use centrifugal separators.

2. Treatment of heavy fuel oils and treatment plant

HFO are contaminated with solid particles and water. If HFO that is dirty or not sufficiently treated goes into the engine, wear on engine components can occur (e.g. piston rings, cylinder liners, injection pumps, valves etc). Also, too much sediment can collect in the combustion spaces.

Sodium in the fuel (which comes from seawater) causes contamination on the pistons and in the turbocharger. The water must be carefully removed from the fuel.

Settling tanks are used for the first steps of treatment, but their effect is only a coarse separation to release water from the HFO. The settling tanks must have the sludge and water, that collects in the bottom of the tank, drained at intervals.

Correctly operated centrifuges that are of the best size and adjustment are used to get good results during the procedure to clean the fuel. Modern designs mean that is not necessary to adapt the gravity discs for fuels of different densities.

Modern machines automatically remove the sludge from the centrifuge. For modern engines designed to burn HFO of the lowest grade, such centrifuges are necessary. This is applicable when HFO with densities of 991 kg/m^3 and higher and with viscosities of $700 \text{ cSt}/50^\circ\text{C}$ are used. For more data, see 0710-1 Diesel Engine Fuels.

Homogenizers can improve combustion properties, but cannot remove solid particles from the fuel. Homogenizers thus, are only auxiliaries in the treatment plant.

Filters hold solid particles of a specified size and shape, but cannot hold back water. Water will cause the filters to block quickly.

3. Heavy fuel oil and diesel fuel oil separation

It is recommended that modern centrifuges are used for the treatment of heavy fuels.

The separation effect, i.e. the cleaning effect, is related to the flow rate and viscosity of the HFO. Usually, the smaller the volume (m³/h or ltr/h) and the lower the viscosity of the HFO, the better the separation. If the flow rate is too high and/or the separation temperature is too low, the effect of the separator will be decreased.

If the HFO separators do not operate satisfactorily, it is possible that impurities (e.g. cat fines) in the bunkers will not be sufficiently removed. This can cause damage to the engine (e.g. increased wear of piston ring, cylinder liner and fuel injection equipment).

The HFO must be heated before it goes into the centrifuge to keep the temperature constant to a tolerance of $\pm 2^{\circ}$ C. The separation temperature must be as near as possible to 98° C. The instructions of the centrifuge manufacturer must be obeyed during the separation procedure.

The sludge that comes from the separation process must be removed regularly from the separator drum. For self-cleaning centrifuges, the sequence of the procedure can be controlled automatically. But in such a plant, personnel must keep control of the correct function and frequency of procedures. You must do regular checks to make sure that the sludge from the separator drum can drain freely. This prevents back pressure, which makes sure that the centrifuge operates correctly to clean the HFO.

4. Layout of fuel oil system

In the recommended standard plant, pressure is kept in the full fuel system to prevent the evaporation of water in the fuel at the temperature necessary for the heavy fuel oil (HFO). Refer to Fig. 'A'.

At the applicable position of the three-way valve (10), the low pressure pumps (19) supply heavy fuel oil from the daily tank (3, 4) to the mixing unit (21). The booster pumps (22) supplies the fuel from the mixing unit (21) through the end-heaters (23) and fuel filter (24) to the fuel pumps in the supply unit (28). The rated capacity of the booster pump (22) is more than that necessary for the engine. The fuel that the engine does not use flows back to the mixing unit (21). Fuel oil leakage from the mixing unit (21) flows into the clean fuel oil leakage tank (33) or the fuel oil overflow tank (33). You can use the clean fuel oil leakage tank (33) to isolate marine diesel oil (MDO) or marine gas oil (MGO) leakage from HFO leakage.

The pressure regulating valve (17) sets the applicable system pressure. The pressure retaining valve (27) sets the pressure at the inlet to the fuel pumps (for the adjustment value, see 0250-1 Operating Data Sheet).

The pump (19) supplies only as much heavy fuel oil from the HFO daily tank (3) as necessary for the engine. If necessary, the temperature of the heavy fuel oil in the HFO daily tank (3) must be increased.









Remark: The official safety regulations give a maximum temperature limit of the heavy fuel oil (HFO).

The temperature of the fuel between the mixing unit (21) and the fuel system on the engine must be increased to the applicable injection temperature. The end-heater (23) increases the temperature of this fuel. If necessary during the temperature increase, the heating systems of the mixing unit (21) and the return pipe can be set to on.

HFO must not go into the marine diesel oil (MDO) daily tank (6).

Fuel Treatment, Fuel Oil System

Key to Illustrations: 'A' Schematic Diagram – Fuel System

1	HFO settling tank	18	Suction filter
2	HFO/LSHFO settling tank	19	Low pressure supply pump
3	HFO daily tank	20	Air overflow pipe
4	LSHFO daily tank	21	Mixing unit, heatable and insulated
5	MDO settling tank	22	Booster pump
6	MDO daily tank	23	End heater
7	Self-cleaning MDO separator	24	Fuel filter
8	MDO separator supply pump	25	Fuel rail
9	MDO suction filter	26	Fuel leakage rail unit
10	Three-way valve	27	Pressure retaining valve
11	HFO/LSHFO preheater	28	Supply unit (fuel pump)
12	HFO/LSHFO separator supply pump	29	Fuel leakage pipe injection valve
13	Suction filter	30	Main engine
14	Self-cleaning HFO/LSHFO separator	31	Sludge tank
15	Bypass pipe	32	Clean fuel oil leakage tank
16	Automatic fuel change-over unit	33	Fuel oil overflow tank
17	Pressure regulating valve		
DAH Differential pressure alarm high			
DPI Differential pressure indication			
LAH Fluid level alarm high			
LAL Fluid level alarm, low			
PI Pressure indicator			
TI Temperature indicator			
VAH Viscosity alarm high			
	Flow indicator		
	Heated & insulated pipes		
	Insulated pipes		
	Pressure regulating valve		
	Sight glass		
	Viscosimeter		

Operating Media
Fuel Treatment, Fuel Oil System

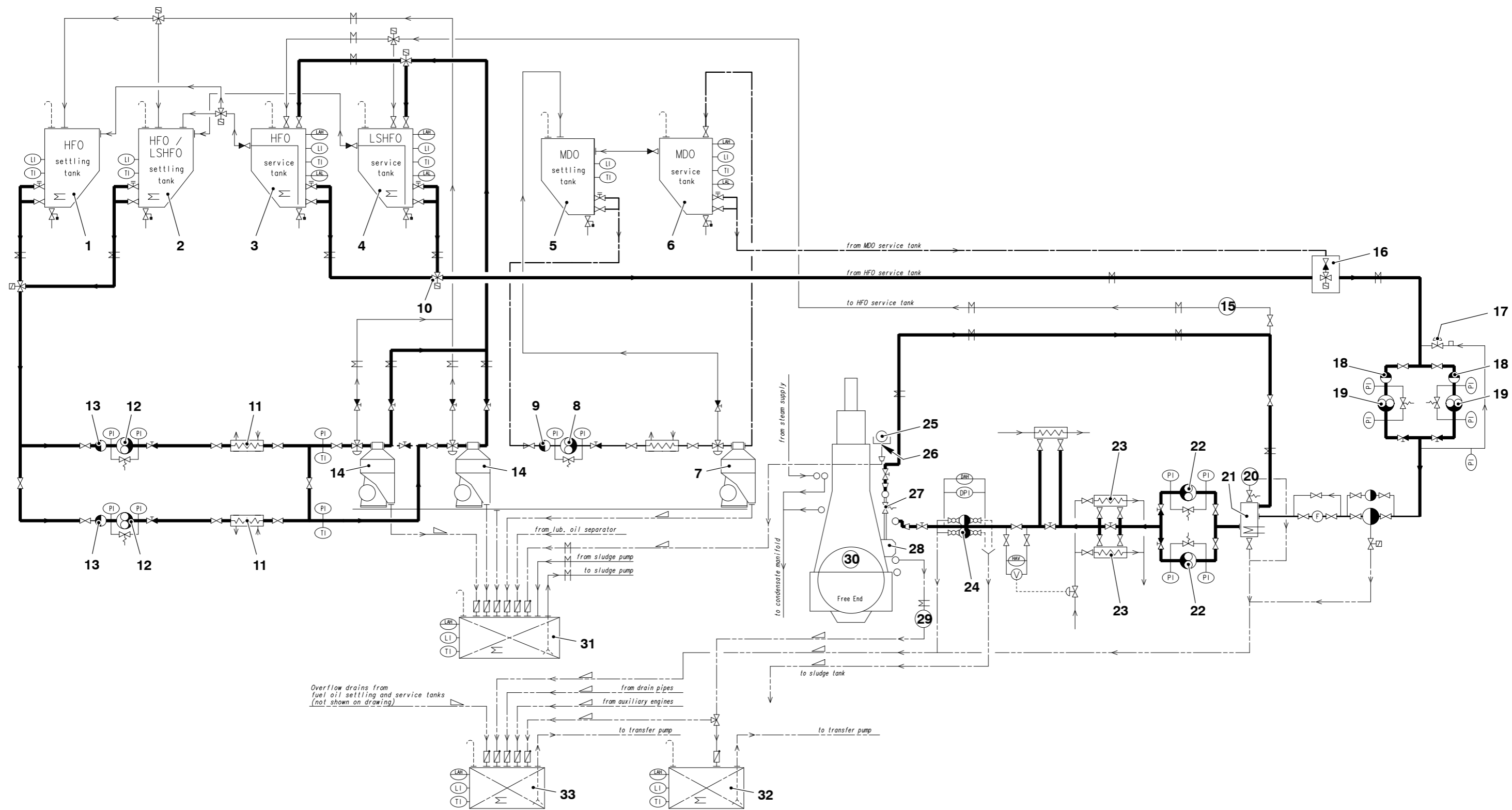

Intentionally blank

Operating Media

Scavenge Air and Compressed Air

1. Scavenge air

The turbocharger compresses the air necessary for scavenge air and charge air for the cylinders, from the engine room or from outside (see Turbocharging [6500-1](#)).

The air must be as clean as possible to keep the wear of cylinder liner, piston rings, turbocharger compressor etc. to a minimum. Silencers are installed to the suction part. The silencers have filter mats in them, which help to keep the air clean. The filter mats must be serviced and/or cleaned regularly (see [6510-1](#) Cleaning the Turbocharger during Operation).

2. Compressed air

2.1 Starting air

Compressors pump air into the starting air bottles to a maximum of 30 bar. The starting air from the starting air bottles enters directly into the cylinder. This air must be clean and dry. The starting air bottles must be regularly drained to remove condensation (see [8018-1](#) Starting Air Diagram).

2.2 Control air

The control air and air spring air supplied from the shipboard system must be clean and dry.

If no air comes from the control air board supply, compressed air at decreased pressure is available from the starting air supply (see [4003-2](#) Control Diagram).

Intentionally blank

Operating Media

Lubricating Oils

Overview

1.	General	1/16
2.	System Oil system	1/16
3.	Cylinder Lubricating Oil	6/16
4.	Turbocharger Oil	12/16
5.	Turning Gear Oil	12/16
6.	Lubricants – Flywheel and Pinion Gear Teeth	12/16
7.	Environmentally Acceptable Lubricants	12/16
8.	Validated Lubricating Oils	13/16

1. General

The engine has different oils for system oil and cylinder lubrication.

2. System Oil

System oil lubricates the bearings, the running parts of the engine and the crosshead assembly. System oil is also used as hydraulic fluid in the servo oil system of the engine and used to cool the pistons (see 8016-1 Lubricating oil system).

The system oil must have the properties that follow:

- An additive-type crankcase oil of the SAE 30 viscosity grade must be used as system oil.
- The oil must have a minimum base number (BN) of 5.0 mg KOH/g and detergent properties.
- The oil must have the load carrying performance from the FZG gear machine test method A/8, 3/90 in accordance with ISO 14635-1, failure load stage 11 as a minimum.
- The oil must also have good thermal stability, anti-corrosion and anti-foam properties, and good demulsifying performance.



Remark: Validated system oils for Wärtsilä 2-stroke engines are shown in paragraph 8.2. For different or new lubricating oils, speak to or send a message to Winterthur Gas & Diesel Ltd. or Wärtsilä Services Switzerland Ltd.

2.1 Oil Care

2.1.1 System Oil

To keep the lubricating oil in good condition for long periods, good oil treatment is necessary. To do this, a self-cleaning, centrifugal separator is used.

A self-cleaning, centrifugal separator is used as a purifier in by-pass. The oil flows from the oil tank through the centrifugal separator. The system oil volume must be put through the centrifugal separator a minimum of three times each day. The manufacturer of the centrifugal separator sets the output. The recommended oil temperature for this treatment is between 96 °C and 98 °C unless otherwise recommended by the centrifugal separator supplier.

Lubricating Oils

Solid contaminants (dirt) and water must be removed from the oil as completely as possible. There is always a risk that water, specially sea water, can enter the system and cause corrosion on engine parts. Water contamination can also cause bacterial infection of the oil, which gives a decrease in lubrication and heavy corrosion of the system. Good maintenance is the best precaution to keep water out of the oil. The water content of the lubricating oil must not be more than 0.2% by mass during a long period. If higher water contamination is seen, special procedures such as treatment in the centrifugal separator, or in a renovating tank must be done.

Make sure that the coarse and fine filters of the servo oil system are serviceable. For more data, see the documentation of the fine filter manufacturer and paragraph 2.3.2.

2.1.2 Servo Oil System

To increase the lifetime of the sliding parts, fine-filtered oil is used in this system. This fine-filtered oil, which is divided from the system oil, flows through an automatic filter which flushes back to the system oil.

The process and the low differential pressure must be monitored during the operation of the automatic filter (see 0240-1 Usual operation and documentation of the automatic filter manufacturer).

The bypass filter element can be used temporarily to inspect and clean the regular filter elements, or if these must be removed.

2.2 Limits for Selected System Oil Parameters

You make an analysis of the selected parameters to estimate the condition of the lubricating system oil. Regular checks can find deterioration early and procedures can be done to correct the problems.

Make sure that the limits of the system oil are not more than those given in the Table 1 for long periods in service.

Table 1: Alert Limits of System Oil Parameters

Parameter	Limit	Test Method
Viscosity at 40 °C	Maximum 140 mm ² /s [cSt]	ASTM D 445
Flash point (PMCC)	Minimum 200 °C	ASTM D 92
Total insolubles	Maximum 0.70% m/m ¹⁾	ASTM D 893b
Base Number (BN)	Maximum 12 mg KOH/g	ASTM D 2896
Water content	Maximum 0.20% m/m	ASTM D 95 or ASTM D 1744
FZG gear machine test	Minimum failure load stage 9	ISO 14635-1 (test method A/8.3/90)

1) % m/m means by mass, e.g. a water content of 0.20% m/m means that the water content is 0.20% of the mass of the total solution.

If one of the limits of the system oil is at a value given in the table above, applicable procedures must be done to correct the problem. Such procedures can be purification (decrease of the flow rate, adjustment of temperatures), treatment in a renovating tank (settling tank) or partial exchange of the oil charge. It is recommended that you speak to the oil supplier in such a condition.

The oil condemnation limits are given in Table 2. If the oil condition has so much deterioration that the purifier and filters cannot make the condition better, some of the oil charge must be replaced. The oil charge will then go back to a satisfactory performance level.

Lubricating Oils

Table 2: Condemnation Limits

Parameter	Limit	Test Method
Viscosity at 40 °C	Maximum 150 mm ² /s [cSt]	ASTM D 445
Flash point (PMCC)	Minimum 180 °C	ASTM D 92
Total insolubles	Maximum 1.0 % m/m	ASTM D 893b
Base Number (BN)	Maximum 15 mg KOH/g	ASTM D 2896
Water content	Maximum 0.30 % m/m	ASTM D 95
Strong Acid Number (SAN)	nil mg KOH/g	ASTM D664
Calcium	Maximum 6000 mg/kg [ppm]	ICP
Zinc	Minimum 100 mg/kg [ppm]	ICP
Phosphorous	Minimum 100 mg/kg [ppm]	ICP
FZG gear machine test	Minimum failure load stage 8	ISO 14635-1 (test method A/8.3/90)

These limits are a guide. The condition of the oil in the system cannot be fully calculated by one parameter. Other oil parameters must be used to find the cause of the problem, and the applicable treatment.

If the Base Number (BN) of the system oil increases suddenly, do a check of the piston rod gland box and piston rod condition.

If the Base Number (BN) of the system oil increases suddenly, do a check of the piston rod gland box and piston rod condition.

Some consumption and replenishment of the system oil is necessary to keep the oil in good condition.

If there is an important decrease in the flash point below the recommended value shown above, Winterthur Gas & Diesel Ltd. recommends a replenishment of the oil charge.

By a replenishment, an increase in the system oil BN is prevented. A small increase in BN is often an indication that the system oil consumption is low. The open cup type of flash point test procedure (e.g. COC) must be used to decide if some of the oil, or a full oil change is necessary. The closed cup type of flash point test procedure (e.g. PMCC) can be used to monitor the system oil condition, but not for oil change.

The FZG performance (to the procedure in ISO 14635-1) of the oil is important if a new gear wheel is installed or was polished. This gives protection against scuffing during the running-in of the gears.

If the system oil is in use for more than one year, the FZG performance of the oil must be done to make sure that the performance is sufficient for the new or polished gear(s).

You must do regular on-board checks of the BN and water content to get an early indication of a lower oil quality.

2.3 Particle Size and Count

Particle size analysis can give useful data about the wear in an engine. Abrasive particles in the oil can cause wear, thus the procedures must be carefully followed. The hydraulic system operates the exhaust valve and the fuel and cylinder lubricating oil injection systems, (i.e. the servo oil downstream of the fine filter, which is usually 10 µm maximum sphere passing size). Some engines have a 25 µm maximum or other fine filter.

Lubricating Oils

The ISO 4406 particle count and size classes are applicable for the system oil downstream of the filter and given in Table 3.

Table 3: Particle Count and Size Classes

Number of particles per 100 ml			
	More than:	Up to and includes:	Class:
	250 000 000	–	Less than 28
	130 000 000	250 000 000	28
	64 000 000	130 000 000	27
	32 000 000	64 000 000	26
	16 000 000	32 000 000	25
	8 000 000	16 000 000	24
	4 000 000	8 000 000	23
	2 000 000	4 000 000	22
	1 000 000	2 000 000	21
	500 000	1 000 000	20
More than 4 µm maximum	250 000	500 000	19
	130 000	250 000	18
More than 6 µm maximum	64 000	130 000	17
	32 000	64 000	16
	16 000	32 000	15
More than 14 µm maximum	8 000	16 000	14
	4 000	8 000	13
	2 000	4 000	12
	1 000	2 000	11
	500	1 000	10
	250	500	9
	130	250	8
	64	130	7
	32	64	6
	16	32	5
	8	16	4
	4	8	3
	2	4	2
	1	2	1
	0	1	0

The ISO 4406 particle count system operates with three size classes related to a 100 ml oil sample, which are:

- R_4 = number of particles equal to or larger than 4 µm
- R_6 = number of particles equal to or larger than 6 µm
- R_{14} = number of particles equal to or larger than 14 µm.

Lubricating Oils

2.3.1 Recommended Limits for ISO 4406 Particle Count

The specification for a 100 ml oil sample is ISO 4406 19/17/14 maximum in the servo oil downstream of the filter, which means:

- A maximum of 500 000 particles of size equal to or more than 4 μm
- A maximum of 130 000 particles of size equal to or less than 6 μm
- A maximum of 16 000 particles of size equal to or more than 14 μm .

This is the same as the specification before for a maximum of NAS Class 8 particle count.

The samples that follow are acceptable:

- ISO 4406 19/15/11
- ISO 4406 16/13/12
- ISO 4406 15/12/10.

The samples that follow are not acceptable:

- ISO 4406 20/17/13
- ISO 4406 19/16/15
- ISO 4406 20/18/16.

2.3.2 Servo Oil – Particle Counts

If the particle count is more than the limit given, do a check of the coarse and fine filters. This will make sure that all filter elements, gaskets and seals are not damaged. If a high particle count continues and the filters are serviceable, it is possible that an area of wear in the engine causes an unsatisfactory number of particles. Too many particles can also go into the system oil if the piston rod gland boxes do not correctly seal and used cylinder lubricating oil mixes with the system oil.

The purifier removes particles, and you must make sure that the purifier is operated at the correct temperature. Refer to the manufacturers recommendations and make sure that the flow rate is adjusted to get the best operation.

2.4 Oil Samples

At regular intervals, (i.e. at approximately each 3000 operating hours), it is recommended to get a sample of the system oil. Send the the sample of the system oil to a laboratory to make an analysis. The analysis must include ISO 4406 particle counts for samples taken from downstream of the coarse filter or fine filter.

Take the sample downstream of the filter, before the oil flows into the main oil gallery or the servo oil system. Get a sample of system oil as follows:

- 1.) Make sure that the oil pump operates and the engine oil is at the correct temperature for operation.
- 2.) Put an applicable container below a ball valve in the lubricating system.
- 3.) Open the ball valve to flush out possible dirt.
- 4.) Close the ball valve.
- 5.) Use some oil to clean the container.
- 6.) Put the container below a ball valve.

Lubricating Oils

- 7.) Open the ball valve to get a sample
- 8.) Close the ball valve.
- 9.) Put the sample in a bottle.
- 10.) Write the data that follows on the bottle:
 - Name of the ship or name of plant
 - Engine type
 - Engine serial number
 - Date of sample
 - Operating hours of oil and of engine
 - Location of the sample point
 - Oil brand and quality.

3. Cylinder Lubricating Oil

A high-alkaline cylinder lubricating oil of the SAE 50 viscosity grade that has a minimum kinematic viscosity of 18.5 cSt at 100 °C is recommended. But, cylinder lubricating oils of the viscosity grades SAE 40 and SAE 60 can be used in some conditions. The Base Number (BN) measured in mg KOH/g in accordance with method ASTM D 2896 shows the alkalinity of the oil.

To set the correct alkalinity of the cylinder lubricating oil, use an on-board monitoring programme to monitor the piston underside (PU) drain oil. The residual base number (BN) of the piston underside drain oil shows if the setting values for the cylinder lubrication are correct. The BN of the cylinder lubricating oils is not an index for detergency, but a direct measure of alkalinity. The alkalinity of the cylinder lubricating oil must be set in relation to the sulphur content of the fuel, engine operation condition and cylinder lubricating oil feed rate. The higher the sulphur content, the higher the BN of the cylinder lubricating oil must be. For a list of validated cylinder lubricating oils, see paragraph 8.2 Cylinder Lubricating Oils.

When the analysis of the piston underside drain oil shows that the engine operates in the safe area shown in Fig. 2, you can adjust the feed rate and alkalinity of the cylinder lubricating oil. The permitted maximum feed rate is 1.2 g/kWh (see 7218-1 Cylinder Lubrication and 7218-3 Feed Rate - Adjustment). If the analysis of the piston underside drain oil shows that an adjustment to a higher feed rate than 1.2 g/kWh is necessary, you must change to a higher BN cylinder lubricating oil.

Lubricating Oils

3.1 Fuel Sulphur Content and Cylinder Oil Base Number

Fig. 1 shows recommendations of applicable cylinder lubricating oils related to the sulphur content of the used fuel.

If you do not use an on-board monitoring programme to monitor the piston underside drain oil, use the data given in Fig. 1 to choose an applicable cylinder lubricating oil. For data about the applicable feed rates, see 7218-1 Cylinder Lubrication and 7218-3 Feed Rate – Adjustment.

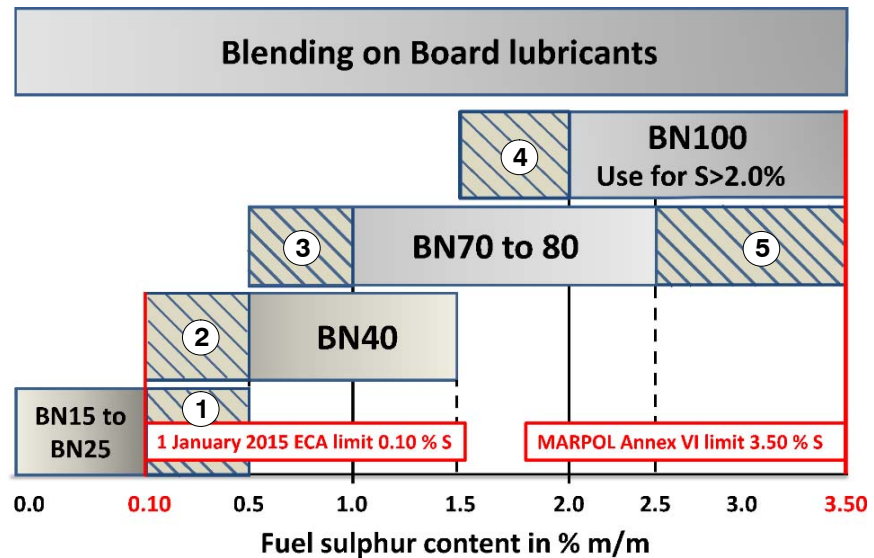

Fig. 1: Relation between Fuel Sulphur Content and Cylinder Lubricating Oil BN

- Range 1 (see Fig. 1): When the fuel sulphur content is more than 0.1% m/m and less than 0.5% m/m during operation with BN 15 to BN 25 cylinder lubricating oil, you must do an analysis of the piston underside drain oil from the on-board monitoring system. You must obey the data that follows:
 - The residual base number must not be less than BN10.
 - The iron (Fe) content must be less than 200 ppm.
 - Do regular checks of the piston and piston ring conditions through scavenge port inspections. If necessary, increase the cylinder lubrication oil feed rate to more than 1.2 g/kWh (see 7218-1 Cylinder Lubrication and 7218-3 Feed Rate – Adjustment).



Remark: Permitted for engine operation of less than 48 hours only.

- Range 2 (see Fig. 1): When the fuel sulphur content is more than 0.1% m/m and less than 0.5% m/m during operation with BN 40 cylinder lubricating oil, adjust the cylinder lubricating oil feed rate to the guide feed rate (see 7218-1 Cylinder Lubrication). This prevents too much piston crown and top land deposits.



Remark: Permitted for engine operation of less than 48 hours only.

- Range 3 (see Fig. 1): When the fuel sulphur content is more than 0.5% m/m and less than 1.0% m/m during operation with BN 70 to BN 80 cylinder lubricating oil, adjust the cylinder lubricating oil feed rate to the guide feed rate (see 7218-1 Cylinder Lubrication). This prevents too much piston crown and top land deposits.



Remark: Permitted for engine operation of less than 48 hours only.

Lubricating Oils

- Range 4 (see Fig. 1): When the fuel sulphur content is more than 1.5% m/m and less than 2.0% m/m during operation with BN 100 cylinder lubricating oil, adjust the cylinder lubricating oil feed rate to the guide feed rate (see 7218-1 Cylinder Lubrication). This prevents excessive piston crown and top land deposits.
- Range 5 (see Fig. 1): When the fuel sulphur content is more than 2.5% m/m and less than 3.5% m/m during operation with BN 70 to BN 80 cylinder lubricating oil, operation is permitted only, when you do an analysis of the piston underside drain oil from the on-board monitoring system. You must obey the data that follows:
 - Do regular checks of the piston and piston ring conditions through scavenge port inspections.
 - Do regular checks of the cylinder liner condition.
 - You must obey the data given in Fig. 2.



Remark: From 1st January 2015 only fuel with less than 0.1% m/m sulphur content must be used in Emission Control Areas (ECA). You can use SO_x scrubbers to reduce the effective exhaust sulphur content. For more data, see paragraph 7.



Remark: Use a BN 100 cylinder lubricating oil, if the fuel sulphur content is more than 2.5% m/m and no piston underside drain oil monitoring system is installed.



Remark: Monitor the piston underside residual BN of the cylinder lubricating oil and examine the piston rings and cylinder liners. This makes sure that you select the applicable BN oil, set the best oil feed rate, prevent corrosion and excessive piston crown deposits and top land deposits. For more data, see 7218-1 Cylinder Lubrication and 7218-3 Feed Rate – Adjustment.

Cylinder lubricating oils that have a BN that is too high for the fuel sulphur content can cause excessive deposits on the piston crown. Piston crown deposits must be carefully monitored through scavenge port inspections. The deposits can cause the lubricant film to break down and excessive liner, piston and piston ring wear.

BN 40 cylinder lubricating oils have neutral additives (low BN) to increase the detergency level and thermal stability to the level of a BN 70 cylinder lubricating oil. No significant increase in corrosive cylinder liner and piston ring wear is to be expected when BN 40 cylinder lubricating oils are used (up to 1.5% m/m sulphur) when the cylinder lubricating oil feed rate is kept high. You must make sure that the cylinder lubrication feed rate is applicable (maximum 1.2 g/kWh), related to the data from the analysis (residual base number) of the piston underside drain oil.

BN 40 lubrication oils cause less and softer deposits on the piston crown land and in exhaust areas (e.g. on the turbocharger nozzle ring) in relation to the BN 70 and other higher BN products at the same feed rate.

The BN 40 products can also be used safely with HFO that has a sulphur content in the range 0.5% m/m to 1.5% m/m. It is possible that the feed rate must be increased in relation to the remaining BN measured in the piston underside drain oil or scrape-down samples.

There are intermediate (between BN 50 and BN 60) and other BN cylinder lubricating oils available. To use these cylinder lubricating oils, make sure that their performance is monitored regularly. Also, make sure that the cylinder lubricating oil feed rate is adjusted to prevent a piston underside BN that is too low. Incorrectly adjusted piston underside BN can cause high corrosive wear and scuffing (see the limits and recommendations in paragraph 3.2).

Lubricating Oils



Remark: Use only the cylinder lubricating oils given in paragraph 8.2. The oil company assumes all responsibility for the performance of the cylinder lubricating oils in service of all Wärtsilä 2-stroke engines to the exclusion of any liability of any Wärtsilä company belonging to the Wärtsilä group. The oil company and other possible manufacturers and distributors of the products in question shall indemnify, compensate and hold free from liability, Wärtsilä and companies belonging to the Wärtsilä group from and against any claims, damages and losses caused by the cylinder lubricating oils in question.

To prevent problems with fuel sulphur content, keep sufficient fuel from the bunker you took before. This can be used until an analysis of the sulphur content of the new bunker is received. The results of the bunker analysis and the values given in the Bunker Delivery Note (BDN) can be different. Always use the higher sulphur content value to set the feed rate to make sure that the engine operates safely.

3.2 Oil Samples – Piston Underside Drain or Scrape-down

Winterthur Gas & Diesel Ltd. recommends to get piston underside drain oil (scrape-down oil) samples at regular intervals from each cylinder and to make an analysis to monitor the engine condition.

These analysis are used to make an estimate of the cylinder liner and piston ring wear and to set the applicable alkalinity and feed rate of the cylinder lubricating oil. The data given in paragraph 3.1, 7218-1 Cylinder Lubrication and 7218-3 Feed Rate – Adjustment are calculated values. The applicable values for each engine can be different, related to the engine and operating conditions.

You can adjust the cylinder lubricating feed rate related to the analysis of the piston underside drain oil. The permitted maximum feed rate is 1.2 g/kWh (see 7218-1 Cylinder Lubrication and 7218-3 Feed Rate – Adjustment). If the analysis of the piston underside drain oil shows that an adjustment to a higher feed rate than 1.2 g/kWh is necessary, you must change to a higher BN cylinder lubricating oil.

The recommended intervals for an analysis of the piston underside drain oil are:

- At each bunker change of the HFO (very important if the sulphur content of the HFO is more than 2.5% m/m).
- At each change of more than 10% CMCR of the average engine (24 hours).
- A minimum of one time each week.

Wear metals, the residual BN, viscosity, fuel components and water are measured. The quantity of system oil additive metals in the sample gives an indication about the piston rod gland box condition. It is important to monitor trends and not full values, and to think about the actual quantity of drained oil relative to the analysis results.

For data about the procedure to get an oil sample from the piston underside, see [8016-1 Lubricating Oil System](#), paragraph 2.1 Dirty Oil Samples.

The total iron in the scrape down oil is measured to determine the corrosion of the liners and steel parts. A large quantity of system oil can be mixed with the used cylinder lubricating oil in the piston underside space. To get an accurate view of the used cylinder lubricating oil, a correction is necessary to remove the effect of the system oil on the results. The iron and residual BN values are corrected in relation to the phosphorus and/or zinc content of the system oil in the used cylinder lubricating oil. This correction analysis must be done carefully because some cylinder lubricating oils also include phosphorus and/or zinc.

Lubricating Oils

The analyses of many piston underside samples from a wide range of engines that operate with a high sulphur content in the range 0.5% m/m to 3.5% m/m and cylinder lubricating oil from BN 40 to Bn 100 has shown:

- The safe corrected piston underside residual BN to prevent piston ring and liner corrosion is more than 25 mg KOH/g but less than 50 mg KOH/g (see Fig. 2).
- The alert corrected limit for piston underside residual BN to prevent excessive corrosion is approximately 15 mg KOH/g.
- The danger corrected limit is less than 10 mg KOH/g piston underside remaining BN. It is possible that there will be excessive corrosion and fast piston ring and liner wear if not corrected. Scuffing and the fast failure of piston rings and very fast corrosive liner wear is possible.

It is necessary to find the safe value for continuous operation on fuel oil with a low sulphur content (of between 0.0% m/m and 0.5% m/m) and a low BN cylinder lubricating oil (between BN 15 and BN 25) for each engine. To find this safe value, you monitor the piston underside samples and do regular checks of the pistons, piston rings and cylinder liners for excessive deposits, corrosion and wear.

Fig. 2 shows data for fuel oil with a sulphur content in the range of 1.5% m/m to 3.5% m/m and cylinder lubricating oil with a base number between BN 50 to BN 100.

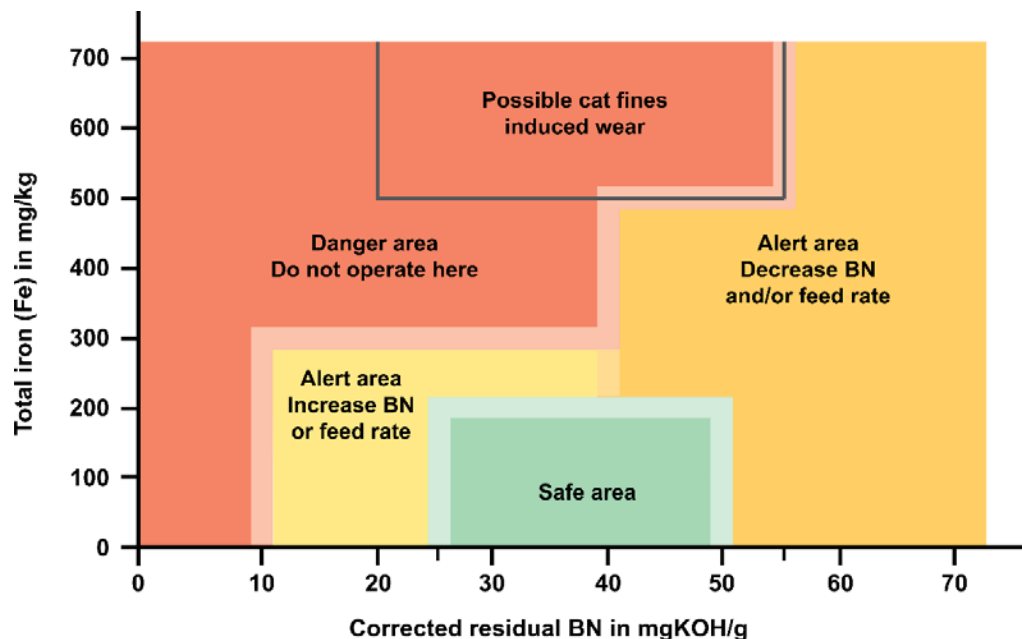

Fig. 2: Piston Underside, Scrape-down or Drip Oil Analysis Interpretation



Remark: There are smooth transitions between the different areas shown in Fig. 2.

Fig. 2 shows the operation ranges for engines with chrome ceramic piston rings and fully honed cylinder liners installed. It shows the relation between the piston underside total oil iron content and the residual BN. If necessary, the cylinder lubricating oil BN and/or feed rate must be adjusted to prevent excessive corrosion or magnetic iron in the piston underside oil.

Lubricating Oils

For engines with chrome ceramic piston rings installed, the chromium content of the piston underside oil shows if there is corrosion or wear in the engine.

- A chromium content less than 25 mg/kg shows small corrosion or wear in the engine.
- A chromium value more than 25 mg/kg shows corrosion or wear in the engine. The lifetime of the piston rings and the cylinder liners can decrease.
- The chromium value must not be more than 25 mg/kg for a longer period.



Remark: Engines with cast iron or non-chrome ceramic piston rings installed, can have a much larger total iron level than engines with chrome ceramic piston rings under usual operation conditions.

3.3 General Recommendations

Service experience has shown that the corrosion behavior can vary significantly while the engine operates at less than 60% CMCR (low load).

If the engine is to be operated at continuous low load (i.e. more than 24 hours of operation below 60% CMCR) and the sulphur content of the used HFO is more than 2.5% m/m, Winterthur Gas & Diesel Ltd. strongly recommends the use of a BN 100 cylinder lubricating oil, as the cylinder oil feed rate cannot be adjusted to adequately compensate for the lower alkalinity. If you use a cylinder lubricating oil with a BN less than 100, the permitted maximum feed rate is 1.2 g/kWh (see 7218-1 Cylinder Lubrication and 7218-3 Feed Rate – Adjustment). If the analysis of the piston underside drain oil shows that an adjustment to a higher feed rate than 1.2 g/kWh is necessary, you must change to a BN 100 cylinder lubricating oil.

For data about validated cylinder lubricating oils, see paragraph 8.2.



Remark: You can use the Wärtsilä Blending on Board package to adjust the base number of the cylinder lubricating oil. For more data, speak to or send a message to Winterthur Gas & Diesel Ltd. or Wärtsilä Services Switzerland Ltd.

It is necessary to monitor the residual BN at regular intervals (see paragraph 3.1 and paragraph 3.2). Winterthur Gas & Diesel Ltd. recommends the use of an on-board monitoring programme that, at a minimum, gives you an analysis of the residual BN from the piston underside drain oil. Winterthur Gas & Diesel Ltd. also recommends the analysis of the total iron and chromium content in the piston underside oil. A sudden increase of the iron or chromium content indicates excessive cold corrosion (see paragraph 3.2). For more data, see Technical Bulletin RT-161.

3.4 Intermediate BN Lubricating Oils

If an intermediate BN cylinder lubricating oil (BN is more than 40 mg KOH/g and less than 70 mg KOH/g) is used, Winterthur Gas & Diesel Ltd. recommends the procedures that follow:

- Use an on-board monitoring programme that, at a minimum, gives you an analysis of the residual BN from the piston underside drain oil. The recommended intervals for an analysis are:
 - a) At each bunker change of the HFO (very important if the sulphur content of the HFO is more than 2.5% m/m).
 - b) At each change of more than 10% CMCR of the average engine (24 hours).
 - c) A minimum of one time each week.

Lubricating Oils



Caution: For engine operation at less than 60% CMCR (low load) for more than 24 hours, you must only use intermediate BN lubricating oils (between BN 50 and BN 60) if the sulphur content of the used HFO is in the range of 0.5% m/m to 2.5% m/m.

4. Turbocharger Oil

To select the turbocharger lubricating oil and keep this oil in a satisfactory condition, refer to the recommendations given in the turbocharger instruction manual.

The turbocharger lubricating oil is usually system oil or turbine oil.

5. Turning Gear Oil

To select the turning gear oil and keep this oil in a satisfactory condition, refer to the recommendations given in the instruction manual of the turning gear manufacturer.

6. Lubricants – Flywheel and Pinion Gear Teeth

To select and apply the lubricants, refer to the specification in the Maintenance Manual 3206-1, and the recommendations from the engine manufacturer.

The lubricant suppliers are given in paragraph 8.4.

7. Environmentally Acceptable Lubricants

Environmentally Acceptable Lubricants (EAL) are currently required for ships operating in USA waters, and this area may be extended in future.

These lubricants which are required for all oil-to-sea interfaces, which include stern tubes, thrusters, rudders, stabilizers, variable pitch propellers, underwater ropes and machinery and underwater transmissions are made with base oils and additives which are significantly different to those used for system and cylinder oil.

Consequently, EAL should not be mixed into system or cylinder oils where they are to be used in engine applications. Even small contamination of EAL (depending on base oil quality) into system and cylinder oil can lead to elastomer compatibility, water emulsification and high temperature deposit formation issues.

Lubricating Oils

8. Validated Lubricating Oils

8.1 Lubricating Oil Instructions and Liability

The application and handling of lubricating oils must be in compliance with the Wärtsilä general lubricating oil requirements and recommendations given in the Operation Manual (this manual) and the Maintenance Manual. Also, refer to the Service Bulletins RT-138, RT-138 Appendix 1, RT-138 Appendix 2 and RT-161.

The supplier oil company takes all responsibility for the performance of the oil in service to the exclusion of any liability of Winterthur Gas & Diesel Ltd. or Wärtsilä Services Switzerland Ltd.

Lubricating Oils

8.2 Cylinder Lubricating Oils

Table 4: List of Validated Lubricating Oils (Last Update: January 2015)

Oil Supplier	15 ≤ BN ≤ 25 ⁶⁾	BN 40 ⁶⁾	50 ≤ BN ≤ 60 ⁶⁾	70 ≤ BN ≤ 80 ⁶⁾	BN 100 ⁶⁾
Aegean	Alfacylo 525 DF (BN 25) ⁵⁾	–	–	Alfacyclo 570 (BN 70) ⁵⁾	Alfacyclo100 HS ⁵⁾
Bardahl	–	–	–	Naval 50 (BN 70)	–
Castrol	AW0053 (BN 16)	Cyltech 40 SX (BN 40)	–	Cyltech 70 (BN 70); Cyltech 80 AW (BN 80)	Cyltech 100 ⁵⁾
Chevron	Taro Special HT LF (BN 25)	Taro Special HT LS 40	Taro Special HT 55 (BN 55) ³⁾	Taro Special HT 70 (BN 70); Taro Special 70 (BN 70) ⁴⁾	Taro Special HT 100 ⁵⁾
ENI	–	–	–	Punica 570 ⁵⁾	–
ExxonMobil	Mobilgard 525 (BN 25)	Mobilgard L 540	Mobilgard 560VS (BN 60) ¹⁾	Mobilgard 570 (BN 70)	Mobilgard 5100
FL Selenia	–	–	–	MECO 5070 (BN 70)	–
Gdanska	–	–	–	Marinol RG 7050 (BN 70) ⁴⁾	–
Gulf Oil Marine	GulfSea Cylcare ECA 50 (BN 15)	GulfSea DCA Cylcare 5040H ⁵⁾	–	GulfSea Cylcare DCA5070H (BN 70)	GulfSea Cylcare 50100 ⁵⁾
IOC	–	–	–	Servo Marine 7050 (BN 70)	–
JX Nippon Oil & Energy	–	Marine C405 (BN 40) Marine C405Z (BN 40)	–	Marine C705 (BN 70)	–
LUKOIL	Navigo MCL Ultra (BN 20) ⁵⁾	Navigo 40 MCL	–	Navigo 70 MCL (BN 70)	Navigo 100 MCL
Mexicana de Lubricantes	–	–	–	Marinelub 7050 (BN 70) ⁴⁾	–
Pertamina	–	–	–	Medripal 570 (BN 70)	–
Petrobras	–	Marbrax CID-54-APN	Marbrax CID-55 (BN 50) ²⁾	Marbrax CID-57 (BN 70)	–
PetroChina	–	–	–	KunLun DCA 5070H (BN 70)	–
Shell	Alexia S3 (BN 25)	–	Alexia S4 (BN 60) ¹⁾	Alexia 50 (BN 70); Alexia S5 (BN 80)	Alexia S6
SINOPEC	Cylinder Oil 5025 (BN 25) ⁵⁾	Cylinder Oil 5040 ⁵⁾	–	Cylinder Oil 5070 (BN 70) ⁴⁾ ; Cylinder Oil 5070S (BN 70); Cylinder Oil 5080S (BN 80)	Cylinder Oil 50100 ⁵⁾
SK	–	Supermar CYL 40 (BN 40); Supermar CYL 40L (BN 40)	–	Supermar Cyl 70 plus (BN 70)	–
Total	Talusia LS 25 (BN 25)	Talusia LS 40 (BN 40)	Talusia Universal (BN 57) ¹⁾	Talusia HR 70 (BN 70)	Talusia Universal 100

Lubricating Oils

**Remarks:**

- 1) BN 57 and BN 60 cylinder lubricating oils can be used for the sulphur range:
 - Between 0.5% m/m and 3.5% m/m if an on-board monitoring programme is used.
 - Between 0.5% m/m and 2.5% m/m if no on-board monitoring programme is used, the engine was built before the year 2011 and the engine load is less than 60% CMCR for more than 24 hours. You must obey the data given in paragraph 3.3.

If there is a sulphur dependency application, the lubricating oils must be considered as BN 57 and BN 60 as applicable. The BN 60 break-point and feed rate adjustment must be applied, see 7218-1 paragraph 6.4 Adjustment Lubricating Oil Feed Rate.
- 2) For engines built before the year 2000, BN 50 cylinder lubricating oils can be used with HFO with a sulphur content up to 2.5% m/m.
- 3) For engines built before the year 2011, BN 55 cylinder lubricating oils can be used for the sulphur range:
 - Between 1.5% m/m and 2.5% m/m for continuous operation, and
 - Between 0.5% m/m and 1.5% m/m for intermittent operation up to 10 days.
- 4) Applicable only for engines built before the year 1995.
- 5) These cylinder lubricating oils are not validated at this time.
- 6). The Base Number (BN) measured in mg KOH/g in accordance with method ASTM D 2896 shows the alkalinity of the oil.



Remark: Intermediate cylinder lubricating oils (BN is more than 40 mg KOH/g and less than 70 mg KOH/g) can be used, but their performance must be regularly monitored. The lubricating oil feed rate must be adjusted to prevent a piston underside BN which is too low and can cause excessive corrosive wear and scuffing. See the data given in paragraph 3.4.

You must be very careful, if you use intermediate BN lubricants and HFO with a sulphur content more than 2.5% m/m.



Remark: If HFO with a sulphur content of between 1.5% m/m to 3.5% m/m is used, see the data given in paragraph 3.2.

Lubricating Oils

8.3 System Oils

Table 5: List of Validated System Oils (Last Update: January 2015)

Oil Supplier	Brand
Aegean	Alfasys 305 ²⁾
BP	Energol OE-HT 30
Castrol	CDX 30
Chevron	Veritas 800 Marine 30
ENI	Cladium 50
ExxonMobil	Mobilgard 300 Mobilgard 300 HD ¹⁾
FL Selenia	MESYS 3006
Gulf Oil Marine	GulfSea Superbear 3008 GulfSea Superbear 3006
IOC	Servo Marine 0530
JX Nippon Oil & Energy	Marine S30
LUKOIL	Navigo 6 SO Navigo 6 CO
Pertamina	Medripal 307
Petrobras	Marbrax CAD-308
PetroChina	KunLun DCC3008 KunLun DCC3005H ²⁾
Shell	Melina S30 Melina 30
SINOPEC	Marine System Oil 3005 Marine System Oil 3006 Marine System Oil 3008
SK	Supermar AS
Total	Atlanta Marine D 3005

1) Applicable only for RT-flex and W-X engines built after February 2012.

2) These cylinder lubricating oils are not validated at this time.

8.4 Lubricants – Flywheel and Pinion Gear Teeth

To correctly apply the lubricants oils given in Table 6 see the Maintenance Manual 3206-1.

Table 6: List of Lubricants – Flywheel and Pinion Gear Teeth (Last Update: October 2012)

Supplier	Brand
Lubrication Engineers Inc.	LE 5182 PYROSHIELD
Klüber Lubrication München KG	Klüberfluid C-F 3 ULTRA

Operating Media

Cooling Water / Cooling Water Treatment

1. General

An applicable treatment is used to give the cooling water the correct properties, which will prevent service problems. Untreated cooling water can soon cause problems in the cooling system from corrosion, sediment and hard particles (crusts).

2. Raw water for closed cooling water circuits

To fill the system the raw water must be completely desalinated. Condensate water from e.g. the fresh water generators or from auxiliary steam systems can be used, but must have additives. Condensate water is highly corrosive and must have corrosion inhibitors to prevent problems.

Use potable water or process water from the local mains only as a last option. The hardness of this water must not be more than 10° dH (German hardness degrees). If the hardness is more than this limit, desalinate the water to the values given in the table below.

See the data in the table that follows to get the necessary raw water quality:

Parameter	Value
Hardness	3° dH to 10° dH
Content of chlorides and sulphates	not more than 100 mg/liter
pH value	8 to 10

Do not use seawater as raw water. Sea water has a high salt content.

In you think there is a problem, do an analysis of the water. Send the results of the analysis to Wärtsilä Services Switzerland Ltd to get advice.

Corrosion protection oils (emulsion oils) are not recommended for the treatment of the cooling water. If instructions about the use of corrosion protection oils are not obeyed and coolant checks are not sufficient, then water-oil emulsion can occur. This can cause the cooling system to become clogged.

3. Cooling water during operation

As given above, the cooling water must have the correct corrosion inhibitor. Well proven in service are inhibitors that contain the agents NITRITE and BORATE. You can get a list of recommended products from Wärtsilä Services Switzerland Ltd. The instructions of the manufacturer must be obeyed for the correct dosage of the corrosion inhibitor. You must do regular checks during operation to keep the correct concentration.

It is recommended that you choose such suppliers of inhibitors who can also give specified advice for the new fill and for during operation.

If there are leakages, you must add the correct quantity of water with the correct concentration of inhibitor. If evaporation causes a decrease of the coolant, add the applicable quantity of raw water (see paragraph 2 above). This will make sure that the concentration of inhibitors is not too much.

The cooling water in the cooling system must have a pH value of 8 to a maximum of 10 (see the table above).

4. Cleaning the cooling water system

For a new fill, the complete cooling system must be clean. The cooling system must not contain grease, oil or unwanted particles.

During operation oil or sediment can go into the system, which can cause a decrease in the heat transfer and cooling effect. Such problems will occur after an unusually short time if the cooling water and system is not monitored correctly. The complete system must be treated with an applicable agent to remove grease and chalk sediment. Before a new fill of treated cooling water, the system must be fully flushed. This will remove sediment and oil and make sure that remaining acids are made neutral.

There are many cleaning agents available, which we do not list here. We recommend that you speak to specialist firms that can help you.

Operating Problems

General

1. General

If the operating and maintenance instructions are obeyed, problems during operation can be prevented.

If a fault occurs, do not search for the cause at random. Use a sequence to find possible causes. This applies specially to problems during engine start and engine stop.

The possible causes of the faults below are given in their related chapters:

1.1 Problems during Engine Start and Stop (see [0810-1](#))

- Engine does not turn during the start sequence
- Engine moves back at start or does not get speed
- Engine turns with air during the start but gets no fuel
- Engine does not fire during the start
- A cylinder does not fire or does not fire correctly during the start
- Engine fires violently during the start
- Engine cannot be stopped.

1.2 Irregular Functions during Operation (see [0820-1](#))

At the same load indication compared to results or with data in the shop trial documents.

- Scavenge air pressure decreases
- Scavenge air pressure increases
- Exhaust temperature upstream of the turbocharger increases
- Exhaust temperature of one cylinder increases
- Exhaust temperature of one cylinder decreases
- Firing pressure of all cylinders decreases
- Engine speed decreases
- Smoke comes out of the exhaust
- Engine runs irregularly or misfires at times (one cylinder or all cylinders)
- Undemanded engine stop
- Irregular functions in the cylinder cooling water system
- Crosshead bearing oil pressure decreases to main bearing oil pressure
- Cylinder lubrication becomes defective
- Problem with the exhaust valve
- Surging of turbocharger(s)
- Oil mist detector gives an alarm.

1.3 Problems and Damage with Engine Parts (see [0840-1](#))

- Hot running of a piston
- Hot running of running gear parts.

1.4 Failures and Defects of WECS Components (see [0850-1](#))

- WECS passive fault
- WECS common fault
- WECS cylinder fault
- WECS pressure fault
- WECS critical fault (WECS engine fault)
- Cylinder lubrication has a malfunction.

Intentionally blank

Operating Problems

Problems during Engine Start and Stop

1. Problems during engine start

For the designations and part code numbers, see [4003-2](#) Control Diagram.

Problem	Possible causes	Procedures
The engine does not turn during the start sequence	The shut-off valves on the starting air bottles are closed.	Open the shut-off valves.
	The starting air pressure is too low.	Fill the air bottles.
	Oil pressure, water pressure or air pressure for the air spring is too low. The pressure switches activated a SHUT-DOWN signal.	Cancel the SHUT-DOWN signal.
	The air spring did not close the exhaust valve (i.e. the upper housing is filled with oil because the lubricating oil pump and servo oil service pump started too early or stopped too late).	Set to off the lubricating oil pump and servo oil service pump. Wait (approximately 30 minutes) until the oil flows out of the upper housing through the orifice. Start the oil pumps only if all the exhaust valves are closed.
Engine start from the control room:	The control stand has no effect.	Push the related button for mode transfer, or to get control.
	The remote control system / telegraph system has a fault.	Do a check of the remote control system (RCS), or speak to the supplier.
	The RCS shows a start interlock.	Do a check of the start interlock indication in the RCS (turning gear, shut-down, auxiliary blower), release the interlock.
	No signal between the RCS and the WECS-9520.	Do a check of the plugs and CAN-BUS, for loose or broken wires.
Engine start at the engine:	Control stand has no effect.	Push the related button for mode transfer, or to get control.
	The turning gear is engaged. The blocking valve 2.13 prevents the flow of control air to the valve unit. E	Disengage the turning gear.
	Control valve 2.05 to shut-off valve for starting air cannot move, or does not open fully	Clean the control valve 2.05.
	The solenoid valves ZV7013C and ZV7014C fail in valve unit. E	Clean or replace, do a check of the cables.
	The electrical connection(s) are disconnected from the solenoid valve(s) in valve unit. E	Connect the electrical connections.

Problems during Engine Start and Stop

Problem	Possible causes	Procedures
	The shut-off valve for starting air 2.03 is in the position CLOSED.	Turn the shut-off valve to the position AUTOMAT..
	The shut-off valve for starting air does not open. The non-return valve cannot move and does not fully open.	Do an overhaul of the shut-off valve.
	The auxiliary blowers do not operate.	Start auxiliary blowers.
	The air flaps in the scavenge air receiver are defective (the auxiliary blowers cannot give pressure).	Do an overhaul on, or replace the air flaps.
	No air spring pressure or pressure too low.	Open the shut-off cock 4.08, adjust the pressure to 6 bar in the control air supply unit. A
	The non-return valve on the exhaust valve (air inlet to air spring) incorrectly installed, loud noises and valve does not completely close.	Do a check and install correctly (see the Maintenance Manual 2751-2)
	The starting valves cannot move, or the electrical connection is not connected.	Do an overhaul on the starting valves, or connect the electrical connection
	Different causes.	Try to start the engine in the opposite direction.
The engine moves back during the start sequence, or does not get speed.	A cylinder receives no air, or the starting air is not sufficient (starting air pipe has a blockage. The solenoid valve(s) ZV7241 (to 48C) cannot move. The cable to the FCM-20 module is broken).	Do a check of the starting air pipe, flame arrester and remove the blockage. Clean or replace the related solenoid valve(s). Do a check of the electrical signal.
	The starting air pressure too low.	Fill the air bottles.
	The shut-off valves and stop valves in servo oil system are in the incorrect positions .	Do a check of the positions (see 0130-1).
The engine turns on starting air, but receives no fuel. Fuel quantity piston stays in position zero %.	Speed control system is defective. No fuel quantity signal released to the fuel quantity sensor.	See documentation of remote control supplier. Do a check of the electrical signal from the speed control system to the WECS-9520.
Engine turns on starting air but receives no fuel.	Fuel rail pressure is too low. The connection between the actuators and the toothed rack is disconnected.	Install the connecting elements (see the Maintenance Manual 5801-1).
	Fuel rail pressure is too low. The toothed rack is blocked in the position zero.	Do a check of the toothed rack. Repair the damage.
	Fuel rail pressure too low. The knurled screw on the fuel pressure control valve 3.06 is not at the bottom stop.	Do a check of the fuel pressure control valve 3.06 (see 0515-1).
	The piston or control slide in the injection control unit 3.02 cannot move. The piston in the rail valve ZV7201 cannot move.	Replace the injection control unit, or the rail valve (see 0515-1).

Problems during Engine Start and Stop

Problem	Possible causes	Procedures
	Heavy leakage in the high pressure fuel system on the engine.	Do a check for leaks, see 8019-1 'Fuel leakage system'.
	Fuel booster pressure is not sufficient. Pressure retaining valve is set too low. Booster pump does not release.	Adjust the fuel booster pressure.
	Shut-off valves upstream of the engine are closed.	Open the shut-off valves.
No ignition during engine start.	Injected fuel quantity is too small. Speed setting position is too low.	Adjust the speed setting
	Fuel is not correct, or its viscosity is too high.	Prepare the fuel oil system (see 0120-1).
	Starting air pressure is not sufficient to turn engine quickly.	Fill the air bottles.
	The auxiliary blower or air flaps in the scavenge air receiver are defective.	Do an overhaul, or replace the auxiliary blower / air flaps.
	Compression pressures are too low, piston rings are in an unsatisfactory condition, exhaust valves do not close correctly.	Replace the piston rings, grind the seating surfaces of the valve head and valve seat.
	High pressure circuit has a leak (fuel pump, rising pipe, fuel rail, injection control unit).	Find the cause and repair the leak with the servo oil service pump in operation. Connect the pipe (tool 94583) between the fuel rail and servo oil rail.
A cylinder does not fire or does not fire correctly during engine start.	Injection control unit cut out by WECS-9520 (function).	Set to on the injection in the remote control (user parameter 'Inj. RUN').
	Injection control unit cut out.	Cut in the injection control unit, see 0510-1 .
	The connections on injection control unit have leaks.	Tighten correctly, grind the sealing faces.
	The solenoid valve(s) ZV7201C (to H) are defective.	Replace the defective solenoid valve(s).
	No electrical signal to the solenoid valve(s) ZV7201C(to H).	Do a check of the cables. Do a check of the LEDs on the FCM-20 module. If necessary replace the FCM-20 module.
	Exhaust valve has a malfunction. No electrical signal to the solenoid valve(s) ZV7201A/B (to 08A/B).	Do a check of the cables. Do a check of the LEDs on the FCM-20 module, if necessary replace the FCM-20 module.
	The injection nozzles have leaks. The needles cannot move.	Replace the injection nozzles.

Problems during Engine Start and Stop

Problem	Possible causes	Procedures
	A hole in the injection nozzle is blocked.	Replace the nozzle tip.
	Compression pressure in the cylinder is not sufficient to ignite the fuel.	Replace the piston rings. Grind the seating faces of the valve head and valve seat.
	The exhaust valve spindle cannot move.	Replace the defective parts.
	No power supply to FCM-20 module. Electrical connection disconnected, or incorrectly connected. Internal fault.	Set to on the power supply. Connect the electrical connection. Replace the FCM-20 module.
	The piston or slide rod in the exhaust valve control unit 4.10, or the piston in rail valve ZV7201 cannot move.	Replace the exhaust valve control unit or the rail valve.
	Exhaust valve control unit is cut out.	Cut in the exhaust valve control unit (see 0520-1).
	Starting valves do not open, cannot move, are damaged or do not get a signal.	Do an overhaul, or replace the starting valves. Do a check of the cables.
Violent firing when starting.	Fuel rail pressure is too high. Fuel control fails.	Do a check of the power supply, cable, toothed rack.
	Cylinders were lubricated too much before engine start. Cylinder lubricating oil has collected in the combustion spaces.	Decrease the speed setting (fuel injection quantity) until the oil has burned. Prevent too much lubrication.
	The auxiliary blowers were not running during the engine starts before. Fuel has collected in the combustion space.	Decrease the speed setting immediately (fuel injection quantity).
	The fuel injection quantity (start fuel charge) is set too high.	Decrease the speed setting (fuel injection quantity).
	The fuel limiter is set too high	Adjust the setting to the standard value.

2. Problems with engine stop

The engine cannot be stopped with rotary knob or the telegraph in the control room.	Cable connector is defective.	Push the EMERGENCY STOP button to stop the engine (see Shutting Down 0310-1).
Engine cannot be stopped with rotary knob on the local control panel.	Cable connector is defective.	Push the EMERGENCY STOP button to stop the engine (see Shutting Down 0310-1).

Operating Problems

Irregular Functions during Operation

1. Load indications

At the same load indication compared to the indications before, or with the data given in the acceptance records.

Problem	Possible causes	Procedures
Scavenge air pressure decreases.	Scavenge air cooler (SAC) dirty on the air side. Water separator dirty or damaged.	See 6606-1 'Air side cleaning of the SAC in service'.
	High intake temperature upstream of the turbocharger.	Make sure that there is an air supply.
	Diffuser, auxiliary blower and inducer to turbocharger is dirty or damaged The silencer upstream of the turbocharger is dirty. The turbine rotor blades are dirty or damaged. Nozzle ring of turbocharger damaged.	See Cleaning the Turbocharger in Operation 6510-1 and the Turbocharger Manual.
	Exhaust gas boiler (plant side) dirty. Increased resistance or back pressure downstream of the turbine.	Clean as soon as possible.
	Nozzle ring of turbocharger is dirty.	See Cleaning the Turbocharger in Operation 6510-1 .
Exhaust temperature upstream of the turbocharger increases.	Air is not sufficient because of a defect, or blockage / dirt in the turbocharger, silencer or scavenge air cooler.	See Cleaning the Turbocharger in Operation 6510-1 'Air side cleaning of the SAC in service' and the Turbocharger Manual.
	The air flaps in the scavenge air receiver cannot move or are defective.	Clean, overhaul or replace the air flaps.
	Injection nozzles are worn.	Replace the injection nozzles.
	High intake temperature upstream of the turbocharger	Make sure that there is an air supply.
	Scavenge ports in the cylinder liner are dirty	Clean the scavenge ports.
Exhaust temperature of a cylinder increases.	Air flaps in the scavenge air receiver dirty or defective.	Clean, do an overhaul or replace the air flaps.
	Injection nozzles are worn.	Replace injection nozzles.
	Scavenge ports in cylinder liner are dirty.	Clean the scavenge ports.
	There is a fire in the piston underside space.	See Measures against Fouling and Fires in the Scavenge Air Spaces 0450-1

Irregular Functions during Operation

Problem	Possible causes	Procedures
	The exhaust valve has a leak.	Grind the valve seat and head.
	The exhaust thermometer of the related cylinder is defective.	Replace the exhaust thermometer.
Exhaust temperature of a cylinder decreases.	Injection nozzles are in an unsatisfactory condition. A nozzle tip is broken.	Replace the nozzle tip.
	The related cylinder gets less fuel because injection pipes or injection valves have leaks.	Grind the sealing faces, or replace defective parts.
	The exhaust valve does not open. The exhaust valve control unit, or its pressure pipe is defective.	Cut out the injection and exhaust valve control unit of the related cylinder (see 0510-1 and 0520-1).
	The exhaust thermometer of the related cylinder is defective.	Replace the exhaust thermometer.
Firing pressure of all cylinders decreases.	The spring, in the connecting unit of the shaft encoder drive, is broken (crank angle sensor unit)	Replace the spring.
Engine speed decreases.	Speed setting from speed control system decreased or is low.	Do a check of the speed control system
	Fuel injection quantity from speed control system is a low setting to prevent too much load in heavy sea.	Usual operation.
	Hull resistance increased because of growth/ageing. Propeller is damaged	See The Relation between Engine and Propeller 0070-1
	A defect in an injection control unit. Defective injection pipe.	Cut out or replace (see 0510-1 and 0515-1)
	Air and exhaust gas openings are dirty.	See paragraph 1, Scavenge air pressure decreases.
Smoke from exhaust.	Air is not sufficient. Exhaust gas side, or air side of turbocharger, scavenge air cooler, air flaps in receiver, scavenge ports in cylinder liners are dirty. Exhaust boiler is dirty.	See paragraph 1, Scavenge air pressure decreases.
	Engine has too much load.	Decrease the fuel injection quantity.
	Engine operates with too much cylinder lubricating oil	See 7218-1 and 7218-2 .
	Injection nozzles do not completely change the fuel into a spray, e.g. because there are trumpets, worn or blocked spray holes	Clean, check and adjust, or replace the injection nozzles.
	Fuel is incorrect, or the viscosity is too high, or not sufficiently heated.	See 0270-1 Recommended viscosity at inlet to fuel pumps.
	Compression pressure is too low. The piston rings, and / or the exhaust valve has leaks.	Replace the piston rings. Grind the valve seat and head.

Irregular Functions during Operation

Problem	Possible causes	Procedures
	The bores in the vent screw for the upper housing of the exhaust valve are blocked. The exhaust valves close too late.	Do a check of the exhaust valve and clean.
	The servo oil pressure is too low. The servo oil pump control is defective. There is oil leakage.	Do a check of the oil flow. Find and repair the leak(s).
	One, or no auxiliary blower operates at part load	Set to on the auxiliary blowers.
Engine runs irregularly or misfires at times, on one or all cylinders.	High water content in the fuel.	See 0720-1 Treatment of heavy fuel oils and treatment plant.
	Fuel temperature upstream of the fuel pumps is too low or too high.	See 0270-1 Recommended viscosity at inlet to fuel pumps.
	Pressure in the fuel rail too low, disturbance with fuel pressure control valve 3.06, one or several fuel pumps do not deliver fuel	See 0515-1 Defective fuel pressure control valve 3.06. Do a check of the pressure transmitter
Engine stops (without a shut-down indication)	Fuel oil daily tank empty, or fuel supply stopped. Fuel oil filters blocked, booster pump defective, switching defective, fuel rail pressure too low, toothed rack defective, fuel leakage.	Fill the daily tank. Clean the filter. Find other causes and repair them. Do a check of the toothed rack. Repair the fault. Find the cause of leaks and repair them.
	Power supply to WECS-9520 is defective.	Find the cause, repair the fault, start the WECS-9520.
	Speed setting system defective, e.g. broken wires.	Repair the fault.
	Engine stops in heavy sea.	Set to on the Heavy Sea Mode see 4002-3 User parameters.
Irregular functions in the cylinder cooling water system Pressure changes irregularly:	Air collects in the cooling spaces or in the pipes because the air cannot flow freely.	Bleed the cooling water system.
	Decrease in static pressure at inlet to cooling water pump because of blockage in the return pipe or the expansion tank is drained.	See plant instructions.
	A crack (in the cylinder liner, cylinder cover, valve cage) causes exhaust gases to go into the cooling water.	See 0545-1 Operation with Water Leakage into the Combustion Chamber.
Increased cooling water temperature at outlet of a cylinder:	Shut-off valves in the pipes of the related cylinder(s) are closed or defective.	Open or replace the shut-off valves.
	Cooling spaces do not have sufficient water flow.	Make sure that there is sufficient water flow.
	Cooling water pipes or water passages blocked. Water does not flow freely.	See Cooling Water / Cooling Water Treatment 0760-1

Irregular Functions during Operation

Problem	Possible causes	Procedures
	Piston runs hot	See 0840-1 Problems and Damage with Engine Parts.
	A crack (in the cylinder liner, cylinder cover, valve cage) causes exhaust gases to go into the cooling water.	See 0545-1 Operation with Water Leakage into the Combustion Chamber.
Increased cooling water temperature on all cylinders:	Plant side is defective (regulating valve, cooling water cooler etc.)	See plant instructions.
Crosshead bearing oil pressure decreases to main bearing oil pressure	Crosshead bearing oil pump is defective. Oil flows through the non-return valve from main bearing oil system	Decrease engine load to 40%. Repair the crosshead bearing oil pump as soon as possible. Until then, increase the main bearing oil pressure as much as possible

2. Cylinder lubrication

If the cylinder lubrication does not operate correctly, the piston rings and cylinder liners will wear quickly. Also, the piston can seize. Only in emergencies, and then at decreased power and only for the minimum possible time can the engine operate without cylinder lubrication.

Faults in the cylinder lubricating system cause related messages in the WECS-9520, which are sent to the alarm and monitoring system.

Also, the LEDs on the ALM-20 modules come on to show the related faults (see also 0850-1 'Malfunction of cylinder lubrication' and 7218-1 'LED indications').

Problem	Possible causes	Procedures
Cylinder lubrication is defective No lubricating oil:	Daily tank is empty. Ball valve downstream of the lubricating oil filter 8.17 is closed or the filter element is clogged. The ball valve downstream of the measurement tube 8.19 is closed	Fill the daily tank. Open the ball valve. replace or clean the filter element.
	There is air in the cylinder lubricating system	Bleed the cylinder lubricating system (the filter, the pump and the pipes to the lubricating quills).
	One or more lubricating quill(s) in the cylinder liner are blocked.	Do a check of the lubricating quill(s). If necessary, do an overhaul, or replace the defective parts.
Lubricating pump is defective:	No servo oil pressure, or pressure is too low.	Open the stop valve 4.30-5. Do a check of the servo oil pressure. Adjust the pressure on the pressure reducing valve 8.11-1 if necessary, or do a check and adjust the settings of the shut-off valve on lubricating pump.

Irregular Functions during Operation

Problem	Possible causes	Procedures
	The 4/2-way solenoid valve, pressure transmitter or pump body is defective.	Replace defective parts (see the documentation of lubricating pump manufacturer)
Exhaust valve problems <i>Exhaust valves knock:</i>	Inside and/or outside piston in the exhaust valve is defective.	Do an overhaul, or replace defective parts.
	Orifice or filter in the exhaust valve control units clogged.	Clean the orifice or filter (see Maintenance Manual 5612-1)
	Holes in the filter of the orifice to the exhaust valve are much larger (wear).	Replace the orifice.
	Leakage in the hydraulic pipe.	Repair the leakage. Replace the pipe.
<i>Exhaust valve does not open:</i>	Non-return valve 4.06 in exhaust valve is defective	Do an overhaul, or replace the non-return valve.
	Piston or slide rod in exhaust valve control unit 4.10 cannot move.	Replace the exhaust valve control unit.
	The rail valve is defective, or cable connection is loose.	Replace the rail valve, or connect the cable connection (see 0525-1 paragraph 3).
<i>Exhaust valve does not close:</i>	Air spring pressure is too low (less than 2 bar)	Find the cause: leakage, pressure reducing valve, pressure in starting air bottles.
	Exhaust valve spindle or onside / outside piston cannot move.	Do an overhaul, or replace the defective parts.

3. Turbocharger

Short, loud noise and the pressure changes irregularly at the same time on the air side.

When this occurs irregularly, surging does not have a direct effect on the engine, but the air flow rate is decreased.

Problem	Possible causes	Procedures
Surging of turbochargers	Too much load. Air is not sufficient.	See 6510-1 Cleaning the Turbocharger in Operation, 6606-1, paragraph 3 Air side cleaning of the SAC in service and Manual of Turbocharger.
	Cylinder becomes defective (injection, exhaust valve control).	Do a check of the injection and exhaust valve control.

Irregular Functions during Operation

4. Oil mist detector



Risk of explosion! Keep away from engine. Do not go into the areas adjacent to the explosion relief valves (see [0460-1](#) Instruction Concerning the Prevention of Crankcase Explosions).

Problem	Possible causes	Procedures
Oil mist detector gives alarm.	Part of a running gear gets too hot.	Decrease the load (rpm) immediately. Stop engine as soon as the possible. Find the cause, repair as much as possible (see 0210-1 Safety Precautions and Warnings and 0840-1 Problems and Damage with Engine Parts).

5. Exhaust waste gate

If the exhaust waste gate is defective and Low-load Tuning causes too much thermal load on the engine, or scavenge air pressure is too high.

Problem	Possible causes	Procedures
Engine has too much thermal load (slow-down signal released)	Butterfly valve stays in OPEN position at a load range of less than 85%	Adjust the screw for manual operation on the solenoid valve ZV7076C (see 8135-1 , Fig B) Do an overhaul and replace the butterfly valve As a temporary solution, install a blind flange in exhaust bypass and operate engine only up to 85% load
Scavenge air pressure is too high (slow-down signal released)	Butterfly valve stays in the CLOSED position at load range of more than 85%	Do an overhaul and replace the butterfly valve Do a check of the function of the solenoid valve ZV7076C. If necessary, do an overhaul or replace the solenoid valve As a temporary solution, operate the engine only up to 85% load

Operating Problems

Problems and Damage with Engine Parts

1. Hot operation of piston

Possible indications:

In the indications given below, the combustion is correct:

- Temperature increase of the piston cooling oil outlet
- Temperature increase of the jacket cooling water outlet
- Temperature increase of piston underside.

Possible causes	Procedures
<p>Gas blow-by through defective or worn piston rings</p> <p>The cylinder liner surface is scuffed because there is no cylinder lubricating oil.</p>	<p>Cut out the injection of the related cylinder for a short time (see 0510-1 paragraph 1 Cut out the injection).</p> <p>Increase the cylinder lubrication oil feed rate of the related cylinder (see 4002-3 User Parameters and Maintenance Settings, paragraphs 1 and 1.1).</p> <p>If the temperature does not decrease, or increases again after injection is cut in, cut out the injection again (see 0510-1) and stop engine as soon as possible. Wait until the cylinder and piston are sufficiently cool.</p> <p>Do a check of the running surface of the piston and cylinder liner.</p> <p>If the damaged areas are small, use an oil stone to repair these areas.</p> <p>If there is much damage, replace the piston, piston skirt and cylinder liner.</p> <p>If a replacement of these parts is not be possible, remove the piston (see the Maintenance Manual 3403-1, then see 0540-1 Operation with Running Gear Partially or totally Removed, paragraphs 1 and 2).</p>

Problems and Damage with Engine Parts

2. Hot operation of running gear parts

Possible causes	Procedures
Defective oil pipe or pipe connection.	Decrease the speed (power) and increase the bearing oil pressure.
Water in lubricating oil (journals have corrosion).	If the temperature continues to increase, the engine must be stopped to let it become cool.
Dirt in the lubricating oil.	
Damage to the bearing or journals during the install procedure.	Take necessary precautions for preventing crankcase explosions (see 0460-1)
Bearing clearance is not sufficient.	Inspect and disassemble the bearing that was running hot
Bearing has deformation (waisted studs were not tightened in accordance with the instructions).	Do an overhaul, replace the damaged parts, or remove the defective running gear (see 0540-1).
Bearing oil pressure is not sufficient.	Do a check of the pressure gauge and oil pressure monitoring system.
The level in the oil tank is too low. The pump tries to supply air and oil.	

Operation Problems

Failures and Defects of WECS Components

Overview

- 1. **General** 1/39
- 2. **Failure ID and LED indications on FCM-20** 2/39
- 3. **LED indications on ALM-20** 3/39
- 4. **Failure indications** 4/39
- 4.1 **Failure groups** 4/39
- 4.2 **Failure of pulse lubrication** 4/39
- 4.3 **LED On / Off codes** 5/39
- 4.4 **Failure ID** 7/39
- 4.5 **WECS passive failure** 9/39
- 4.6 **WECS common failure** 19/39
- 4.7 **WECS cylinder failure** 31/39
- 4.8 **WECS pressure failure** 34/39
- 4.9 **WECS critical failure (WECS engine failure)** 36/39
- 4.10 **Malfunction of cylinder lubrication** 37/39

3. General

Failures and defects of WECS components cause failure messages which are transmitted to the operator flexView and alarm and monitoring system (AMS).

The tables that follow will help you understand all failure indications. A two-digit LED display for failure ID is given on the FCM-20 or ALM-20. An LED code is given on the ALM-20 that can show some accurate failure indications.



Remark: The two-digit LED display 2 shows the failure ID code (see Fig. A).

Failures and Defects of WECS Components

4. Failure ID and LED indications on FCM-20

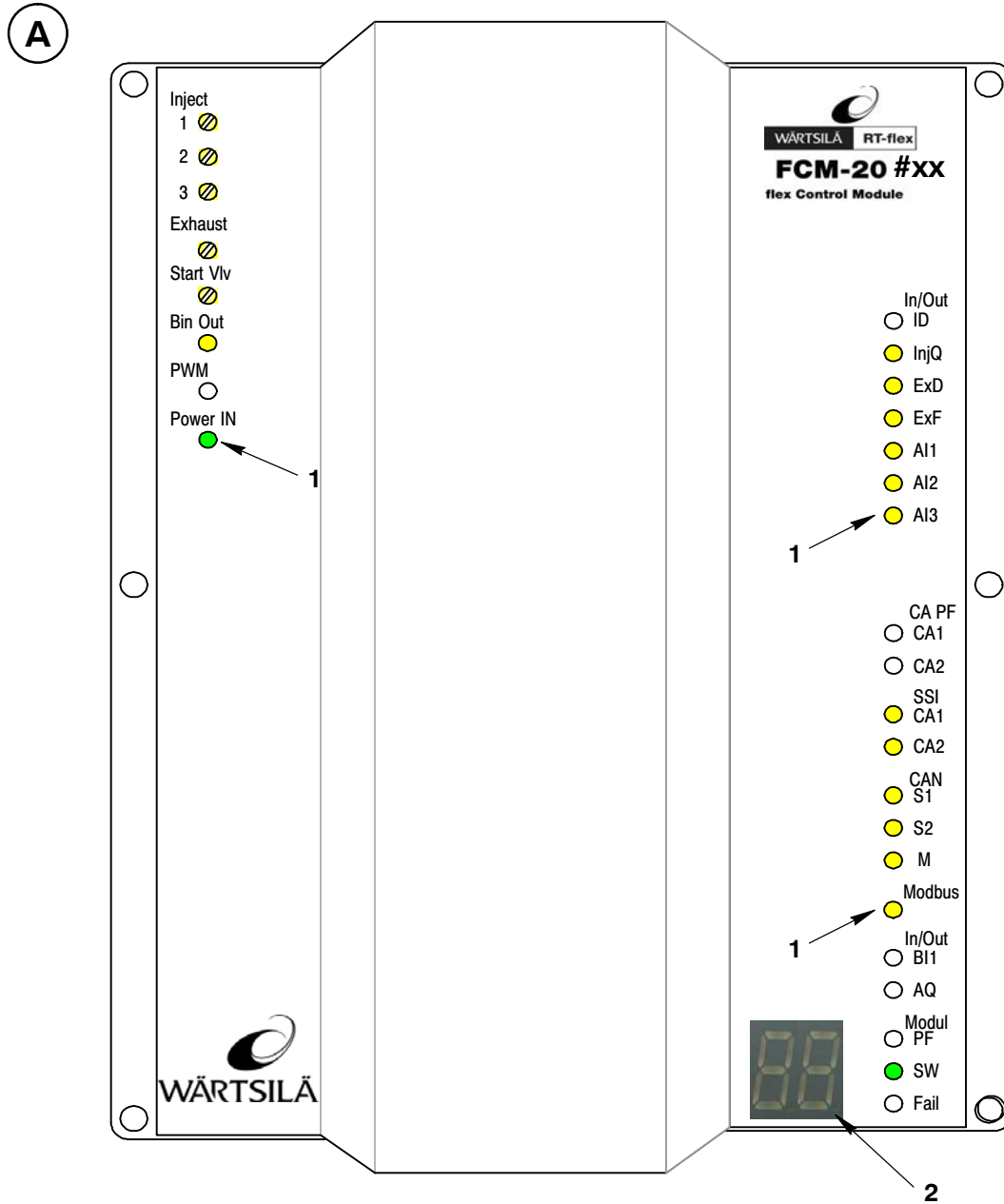

Key to Illustration: Fig. A Failure ID and LED indications on FCM-20
 1 LEDs
 2 Two-digit LED Display

Failures and Defects of WECS Components

5. LED indications on ALM-20

B

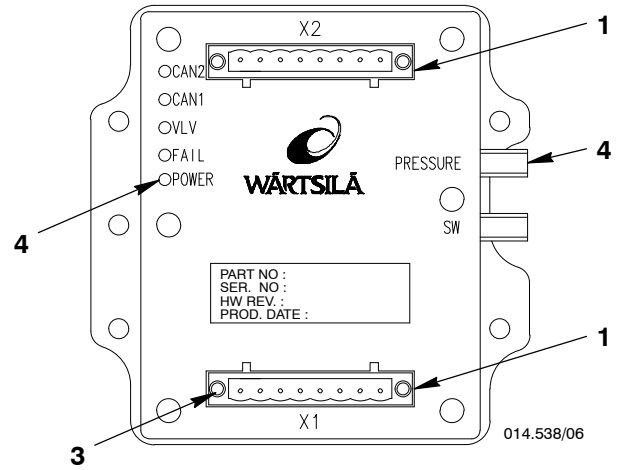
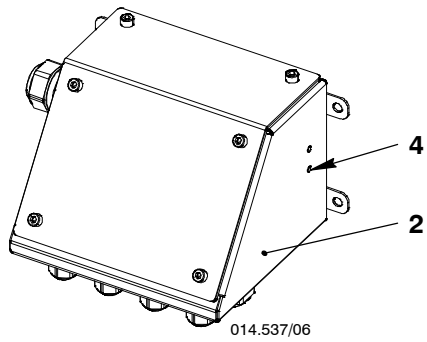

Key to Illustration: Fig. B LED Indications on ALM-20

- 1 Connector (COMBICON)
- 2 Control box 41.nn
- 3 Screw
- 4 LEDs

Failures and Defects of WECS Components

6. Failure indications

4.1 Failure groups

All WECS failure indications are part of the failure groups that follow and are always shown together with the related group.

Failure Group	Failure Effects	Procedures
WECS passive failures	Failures of redundant systems (failure of a redundant component, system or an assembly), do not have direct effect on engine operation	Find the cause and repair as soon as possible
WECS common failures	Common failures have only a small effect on engine operation	Find the cause and repair as soon as possible
WECS cylinder failures	Failures that cause a cylinder malfunction will decrease engine power and immediately activate a slow-down signal in the safety system.	Repair immediately
WECS pressure failures	Some failures in the pressure systems of the engine (fuel, servo oil rail etc.) that have an effect on all of the engine, activate a slow-down signal immediately in the safety system.	Do not override the slow-down signal. Repair the failure immediately.
WECS critical failures (WECS engine failures)	The WECS has an effect on the engine stop	Must be repaired immediately to start the engine

4.2 Failure of pulse lubrication

Type of Failure	Failure Effects	Procedures
WECS lubrication passive failures	Failures do not have direct influence on cylinder lubrication, but they activate a WECS passive failure, i.e. failures of redundant systems (power supply, CAN Bus to ALM-20 or FCM-20)	Find the cause and repair as soon as possible
Cylinder lubrication malfunction Cyl. #n	Failures cause a malfunction of the cylinder lubrication of a cylinder. This activates a slow-down signal in the safety system.	Repair immediately Fuel injection of the related cylinder must be cut out until failure is repaired, see 0510-1 Operation with Injection Cut Out.
Cylinder lubrication malfunction	Some failures cause a malfunction of the cylinder lubrication system. This activates a slow-down signal in the safety system.	Repair immediately Fuel injection of the related cylinder must be cut out until failure is repaired see 0510-1 Operation with Injection Cut Out



Remark: The flexView alarm journal shows more data that can help you. If necessary, you can change all parameters in the Adjust access level. See the Operator flexView manual for instructions about how to change parameters.

Failures and Defects of WECS Components

4.3 LED On / Off codes

4.3.1 Red Fail LED and two-digit LED display

The red Fail LED shows a failure on the related FCM-20 and if the failure status is active or inactive (see Fig. A).

Failure Status	Fail LED	Two-digit LED Display
Active	Flashes	Flashes
Not active (failure recovery)	Stays on	Flashes
No failure	Off	None

4.3.2 Function

Failure IDs give data about failures (see paragraph 4.4).

Not all failure ID signals are transmitted to the alarm and monitoring system. The failure IDs shown on the two-digit LED display are also shown on the flexView.

The Fail LED flashes at the same time as the two-digit LED display.

Failure IDs that are more than 99 are shown as a two-digit display e.g. Failure ID 125 is shown as 2.5.

4.3.3 Failure

The Fail LED flashes three times before the first failure ID is shown.

Each failure ID is shown for 2.7 seconds, then there is a pause of 1.3 seconds before the failure ID is shown again.

If there are no more failures, the Fail LED goes off.

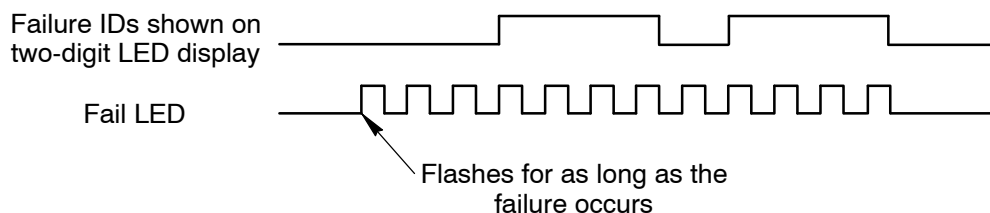

4.3.4 Failure history:

The fail LED is on for 2.4 seconds before the first failure ID is shown.

Each failure ID is shown for 2.7 seconds, then there is a pause of 1.3 seconds before the the failure ID is shown again.

After the failure before is shown, there will be a pause of 20 seconds between two failure IDs.

The failure history is shown for approximately 30 seconds during a 15 minutes period. If there is no more failure history, the fail LED goes off.

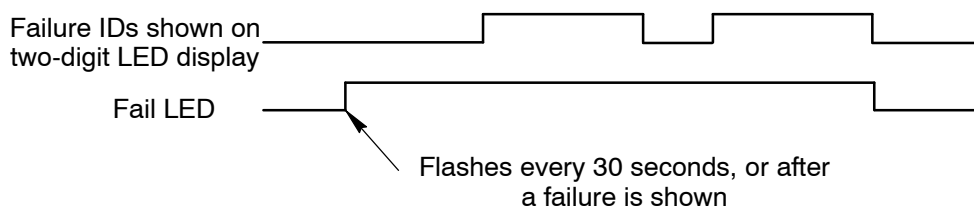

Failures and Defects of WECS Components

4.3.5 LED Indications on FCM-20 at start-up:

On the right side of the the FCM-20:

After the power is set to on, the SSI CA1, CA2 and CAN S1, S2 and M LEDs show red for approximately four seconds. The Fail LED shows red for approximately two seconds. The yellow LEDs In/Out from InjQ to AI3, CAN S1, S2, and M and the green SW LED then come on.

On the left side of the the FCM-20:

After the power is set to on, the green Power IN LED comes on.

Failures and Defects of WECS Components

4.4 Failure ID

ID	Display	Failure text	Failure Group
1	1	ME crank angle #1+2 fail.	WECS critical
2	2	WECS critical failure	WECS critical
3	3	WECS pressure failure	WECS pressure
4	4	WECS cylinder failure	WECS cylinder
5	5	WECS common failure	WECS common
6	6	WECS passive failure	WECS passive
8	8	ME scavenge air pressure sensor #1 meas. fail.	WECS passive
8	8	ME scavenge air pressure sensor #2 meas. fail.	WECS passive
9	9	ME scavenge air pressure sensor #1+2 meas. fail.	WECS common
10	10	ME scavenge air pressure meas. fail. diff. high	WECS common
11	11	ME Scavenge Air Pressure very high	WECS pressure
16	16	ME servo oil pressure sensor #1 meas. fail.	WECS passive
16	16	ME servo oil pressure sensor #2 meas. fail.	WECS passive
17	17	ME servo oil pressure sensor #1+#2 meas. fail.	WECS common
18	18	ME servo oil pressure meas. fail. diff. high	WECS common
19	19	ME servo oil pressure high	WECS common
20	20	ME servo oil pressure low	WECS common
21	21	ME servo oil pressure very low	WECS pressure
26	26	ME servo oil pump #1 fail.	WECS common
26	26	ME servo oil pump #2 fail.	WECS common
26	26	ME servo oil pump #3 fail.	WECS common
27	27	ME fuel rail pressure sensor #1 meas. fail.	WECS passive
27	27	ME fuel rail pressure sensor #2 meas. fail.	WECS passive
28	28	ME fuel rail pressure sensor #1+#2 meas. fail.	WECS common
29	29	ME fuel rail pressure meas. fail. diff. high	WECS common
30	30	ME fuel rail pressure high	WECS common
31	31	ME fuel rail pressure low	WECS common
32	32	ME fuel rail pressure very low	WECS pressure
33	33	WECS any FCM-20 module cyl. ID lost	WECS passive
38	38	WECS CAN M-bus fail. FCM-20 #nn	WECS passive
39	39	WECS Modbus fail. FCM-20 #01	WECS passive
39	39	WECS Modbus fail. FCM-20 #02	WECS passive
42	42	WECS CAN S-/ SSI-bus connection fail. FCM-20 #nn	WECS passive
45	45	ME manual injection cutoff cylinder #nn	WECS cylinder

Failures and Defects of WECS Components

ID	Display	Failure text	Failure Group
60	60	ME crank angle difference between #1 and #2	WECS common
62	62	ME TDC signal fail.	WECS common
63	63	ME crank angle #1 / TDC high shift	WECS common
64	64	ME crank angle #2 / TDC high shift	WECS common
65	65	ME both CA / TDC high shift	WECS critical
66	66	ME crank angle #1 / TDC low shift	WECS common
67	67	ME crank angle #2 / TDC low shift	WECS common
68	68	ME both CA / TDC low shift	WECS cylinder
69	69	ME excessive engine speed	WECS critical
71	71	ME exhaust valve #nn position meas. fail.	WECS passive
78	78	ME exhaust valve #nn fail.	WECS cylinder
80	80	ME injection quantity sensor #nn meas. fail.	WECS common
89	89	ME injection timing fail. cylinder #nn	WECS common
93	93	ME injection quantity piston fail. cylinder #nn	WECS cylinder
94	94	WECS module FCM-20 #00 fail.	WECS passive
95 to 102	95 to 0.2	WECS module FCM-20 #nn fail.	WECS cylinder
110	1.0	ME crank angle #1 fail.	WECS passive
111	1.1	ME crank angle #2 fail.	WECS passive
112	1.2	WECS CAN S1-bus fail.	WECS passive
113	1.3	WECS CAN S2-bus fail.	WECS passive
114	1.4	ME start pilot valve #nn loop fail.	WECS passive
125	2.5	WECS cylinder lubrication passive failure	WECS passive
126	2.6	ME cylinder lubrication malfunction cylinder #nn	Cyl. Lubrication malfunction
128	2.8	ME cylinder lubrication malfunction	Cyl. Lubrication malfunction
155	5.5	ME exhaust waste gate not closed	WECS common
156	5.6	ME exhaust waste gate not open	WECS common
157	5.7	ME scavenge air pressure high	WECS common



Remark: All Failure IDs and indications in this list are for Operator use. The signals of these failures are transmitted to the FCM-20 and are shown on the two-digit LED display (see Fig. B). All failure IDs and indications that are not in this list are for the specialists.

Failures and Defects of WECS Components

4.5 WECS passive failure

Failure Text				
ME scavenge air pressure sensor #1 meas. fail. (ID 8)				
Indication	FCM-20 No.	LED	ID	Display
	#03	AI2	8	8
Cause	Sensor signal < 2mA or > 22mA			
Procedures	⇒ Do a check of the pressure transmitter PT4043C for damage.			
	⇒ Use a multimeter to do a check of the 24 VDC supply on the plug X27 (terminals 94+/96-) in E95.03 and on the transmitter plug (terminals 2+/1-).			
	⇒ If there is a 24 VDC supply, do a check of the cables between the pressure transmitter PT4043C and between E12 and E95.03 for correct connections and / or damage.			
	⇒ Repair or replace damaged cables.			
	⇒ Use a multimeter to do a check of the sensor signal (X27 terminal 95).			
	⇒ If necessary, replace the pressure transmitter PT4043C.			
Indication	FCM-20 No.	LED	ID	Display
	#03	AI2	8	8
Cause	The sensor power supply has a short circuit (red LED)			
Procedures	⇒ In E95.03, disconnect the pressure transmitter PT4043C and the plug X27.			
	⇒ Use a multimeter to do a check between each of the cables on plug X27 terminal 94 and 95 and ground for short circuit or ground fault.			
	⇒ Replace damaged cables, or temporarily repair with insulation tape until spares are available			
	⇒ Do a check of the transmitter PT4043C for a ground fault. Replace the pressure transmitter if necessary.			
	⇒ If failure ID 8 stays on when the plug X27 is disconnected, replace FCM-20 #03			

Failures and Defects of WECS Components

Failure Text	ME scavenge air pressure sensor #2 meas. fail. (ID 8)			
Indication	FCM-20 No.	LED	Failure ID	Display
	#04	AI2	8	8
Cause	Sensor signal < 2mA or > 22mA			
Procedures	⇒ Do a check of the pressure transmitter PT4044C for damage. ⇒ Use a multimeter to do a check of the 24 VDC supply on the plug X27 (terminals 94+/96-) in E95.04 and on the transmitter plug (terminals 2+/1-). ⇒ If there is a 24 VDC supply, do a check of the cables between the pressure transmitter PT4044C and between E12 and E95.04 for correct connections and / or damage. ⇒ Repair or replace damaged cables. ⇒ Use a multimeter to do a check of the sensor signal (X27 terminal 95). ⇒ If necessary, replace the pressure transmitter PT4044C.			
Indication	FCM-20 No.	LED	Failure ID	Display
	#04	AI2	8	8
Cause	The sensor power supply has a short circuit (red LED)			
Procedures	⇒ In E95.04, disconnect the pressure transmitter PT4044C and plug X27. ⇒ Use a multimeter to do a check between each of the cables on plug X27 terminal 94 and 95 and ground for a short circuit or ground fault. ⇒ Replace damaged cables, or temporarily repair with insulation tape until spares are available. ⇒ Do a check of the pressure transmitter PT4044C for a ground fault. Replace the pressure transmitter if necessary. ⇒ If failure ID 8 stays on when the plug X27 is disconnected, replace FCM-20 #04.			

Failures and Defects of WECS Components

Failure Text				
ME servo oil pressure sensor #1 meas. fail. (ID 16)				
	FCM-20 No.	LED	Failure ID	Display
Indication	#01	AI2	16	16
Cause	Sensor signal < 2 mA or > 22 mA (failure signal is released after 3 seconds)			
Procedures	⇒ On the servo oil rail, do a check of the pressure transmitter PT2071C for damage. ⇒ Use a multimeter to do a check of the 24 VDC supply on the plug X27 (terminals 94+/96-) in E95.01 and on the transmitter plug. ⇒ If there is a 24 VDC supply, do a check of the cables between the pressure transmitter PT2071C and E95.01 for correct connections and / or damage. ⇒ Repair or replace damaged cables. ⇒ Use a multimeter to do a check of the sensor signal (X27 terminal 95). ⇒ If necessary, replace the pressure transmitter PT2071C.			
ME servo oil pressure sensor #1 meas. fail. (ID 16)				
	FCM-20 No.	LED	Failure ID	Display
Indication	#01	AI2	16	16
Cause	The sensor power supply has a short circuit (red LED)			
Procedures	⇒ In E95.01, disconnect the pressure transmitter PT2071C and the plug X27. ⇒ Use a multimeter to do a check between each of the cables on plug X27 terminals 94 and 95 and ground for a short circuit or ground fault. ⇒ Replace damaged cables, or temporarily repair with insulation tape until spares are available. ⇒ Do a check of the pressure transmitter PT2071C for a ground fault. Replace the pressure transmitter if necessary. ⇒ If failure ID 16 stays on when the plug X27 is disconnected, replace FCM-20 #01.			
ME servo oil pressure sensor #2 meas. fail. (ID 16)				
	FCM-20 No.	LED	Failure ID	Display
Indication	#02	AI2	16	16
Cause	Sensor signal < 2 mA or > 22 mA (failure signal is released after 3 seconds)			
Procedures	⇒ On the servo oil rail, do a check of the pressure transmitter PT2072C for damage. ⇒ Use a multimeter to do a check of the 24 VDC supply on the plug X27 (terminals 94+/96-) in E95.02 and on the transmitter plug. ⇒ If there is a 24 VDC supply, do a check of the cables between the pressure transmitter PT2072C and E95.02 for correct connections and / or damage. ⇒ Repair or replace damaged cables. ⇒ Use a multimeter to do a check of the sensor signal (X27 terminal 95). ⇒ If necessary, replace the pressure transmitter PT2072C.			
ME servo oil pressure sensor #2 meas. fail. (ID 16)				
	FCM-20 No.	LED	Failure ID	Display
Indication	#01	AI2	16	16
Cause	The sensor power supply has a short circuit (red LED)			
Procedures	⇒ In E95.02, disconnect the pressure transmitter PT2072C and the plug X27. ⇒ Use a multimeter to do a check between each of the cables on plug X27 terminals 94 and 95 and ground for a short circuit or ground fault. ⇒ Replace damaged cables, or temporarily repair with insulation tape until spares are available. ⇒ Do a check of the pressure transmitter PT2072C for a ground fault. Replace the pressure transmitter if necessary. ⇒ If failure ID 16 stays on when the plug X27 is disconnected, replace FCM-20 #02.			

Failures and Defects of WECS Components

ME fuel rail pressure sensor #1 meas. fail. (ID 27)				
Failure Text	FCM-20 No.	LED	Failure ID	Display
Indication	#03	AI1	27	27
Cause	Sensor signal < 2 mA or > 22 mA (failure signal is released after 3 seconds)			
Procedures	⇒ On the fuel rail, do a check of the pressure transmitter PT3461C for damage. ⇒ Use a multimeter to do a check of the 24 VDC supply on the plug X25 (terminal 79+ / housing -) in E95.03 and on the transmitter plug. ⇒ If there is a 24 VDC supply, do a check of the cables between the pressure transmitter PT3461C and E95.03 for correct connections and / or damage. ⇒ Repair or replace damaged cables. ⇒ Use a multimeter to do a check of the sensor signal (X25 terminal 95). ⇒ If necessary, replace the pressure transmitter PT3461C.			
Indication	FCM-20 No.	LED	Failure ID	Display
	#03	AI1	27	27
Cause	The sensor power supply has a short circuit (red LED)			
Procedures	⇒ In E95.03, disconnect the pressure transmitter PT3461C and the plug X25. Remark: ID fault FCM-20 #03 comes on. ⇒ Use a multimeter to do a check between each of the cables on plug X25 terminals 79 and 80 and ground for a short circuit or ground fault. ⇒ Replace damaged cables, or temporarily repair with insulation tape until spares are available. ⇒ Do a check of the pressure transmitter PT3461C for a ground fault. Replace the pressure transmitter if necessary. ⇒ If failure ID 27 stays on when the plug X25 is disconnected, replace FCM-20 #03.			

Failures and Defects of WECS Components

ME fuel rail pressure sensor #2 meas. fail. (ID 27)				
Indication	FCM-20 No.	LED	Failure ID	Display
	#04	AI1	27	27
Cause	Sensor Signal < 2 mA or > 22 mA (failure signal release is 3 seconds delayed)			
Procedures	⇒ On the fuel rail, do a check of the pressure transmitter PT3462C for damage.			
	⇒ Use a multimeter to do a check of the 24 VDC supply on the plug X25 (terminal 79 + / housing -) in E95.04 and on the transmitter plug.			
	⇒ If there is a 24 VDC supply, do a check of the cables between the pressure transmitter PT3462C to E95.04 for correct connections and / or damage.			
	⇒ Repair or replace damaged cables.			
	⇒ Use a multimeter to do a check of the sensor signal (X25 terminal 95).			
	⇒ If necessary, replace the pressure transmitter PT3462C.			
Indication	FCM-20 No.	LED	Failure ID	Display
	#04	AI1	27	27
Cause	The sensor power supply has a short circuit (red LED)			
Procedures	⇒ In E95.04, disconnect pressure transmitter PT3462C and plug X25.			
	Remark: ID fault FCM-20 #04 comes on.			
	⇒ Use a multimeter to do a check between each of the cables on plug X25 terminals 79 and 80 and ground for a short circuit or ground fault.			
	⇒ Replace damaged cables, or temporarily repair with insulation tape until spares are available.			
	⇒ Do a check of the pressure transmitter PT3462C for a ground fault. Replace the pressure transmitter if necessary.			
⇒ Do a check of the pressure transmitter PT3462C for a ground fault. Replace the pressure transmitter if necessary.				

Failures and Defects of WECS Components

Failure Text				
WECS FCM-20 module cyl. ID lost (ID 33)				
	FCM-20 No.	LED	Failure ID	Display
Indication	#00 to #08	ID	33	33
Cause	Identification of jumper setting on X25 is not correct.			
Procedures	⇒ Do a check of the cable address on the plug X25 of the related FCM-20. ⇒ If necessary, repair the cables of the identification jumpers on X25 of the related FCM-20. Remark: If this failure occurs during FCM-20 operation, it will not have an effect on engine operation. If this failure occurs when the FCM-20 is set to off (or an FCM-20 starts again with this failure and continues to have this failure), then the FCM-20 in operation will not start its function again. The related cylinder is cut out.			
Failure Text				
WECS CAN M-bus fail. FCM-20 #01 to #08 (ID 38)				
	FCM-20 No.	LED	Failure ID	Display
Indication	#01 to #08	M	38	38
Cause	CAN M-bus monitoring, but FCM-20 #00 is not defective (failure signal is released after 3 seconds).			
Procedures	⇒ In the related FCM-20 (plug X22, terminals 55/56) make sure that the cables are connected correctly. ⇒ In the control box E90, make sure that the bus cables have no damage and the connections are connected correctly. ⇒ On the PCS (FCM-20 #01 and #02), make sure that the bus cables have no damage and the connections are connected correctly. ⇒ On ECR manual control panel (FCM-20 #03), make sure that the bus cables have no damage and the connections are connected correctly. ⇒ On the local manual control panel (FCM-20 #04), make sure that the bus cables have no damage and the connections are connected correctly. ⇒ Make sure that the CAN M-bus cables between the ALM-20 and the FCM-20 of the last two cylinders have no damage and are connected correctly. ⇒ On the related FCM-20 and control boxes, make sure that the cables, connections and termination at the related FCM-20 and control boxes have no damage and are correctly connected. ⇒ If necessary, replace the related FCM-20.			
Failure Text				
WECS Modbus fail. FCM-20 #01 or #02 (ID 39)				
	FCM-20 No.	LED	Failure ID	Display
Indication	#01 and #02	Modbus	39	39
Cause	Modbus monitoring, no communication (failure signal is released after 3 seconds)			
Procedure	⇒ If the LED does not show, do a check of the cable connection in the related FCM-20 (plug X23, terminals 63/64). ⇒ In the control boxes E90 and AMS / PCS boxes, make sure that the cables have no damage and the connections are connected correctly. ⇒ Make sure that the modbus 120 ohm termination resistors on AMS / PCS and FCM-20 has no damage and is connected correctly (refer to electrical drawings). ⇒ Make sure that the cables, connections and termination in the related FCM-20 and control boxes have no damage and are connected correctly. ⇒ If the failure shows on one module only, replace the related FCM-20.			

Failures and Defects of WECS Components

Failure Text				
WECS CAN S-/ SSI bus connection fail. FCM-20 #nn (ID 42)				
	FCM-20 No.	LED	Failure ID	Display
Indication	#00 (E90)	S1 or S2	42	42
Cause	Missing bus connection on CAN S-bus #1 or CAN S-bus #2 on FCM-20 #00.			
Procedure	⇒ Make sure that each of the two CAN S-bus plugs X22 and X23 are correctly engaged on the online spare FCM-20. ⇒ Make sure that the cable connection on plugs X22 and X23 on FCM-20 online spare module is connected correctly. ⇒ For this FCM-20, set the power supply to off, then on. ⇒ Replace the FCM-20 #00 if the failure continues.			
Failure Text				
WECS CAN S-/ SSI bus connection fail. FCM-20 #nn (ID 42)				
	FCM-20 No.	LED	Failure ID	Display
Indication	#01 to #08	None	42	42
Cause	CAN S-bus #1 and crank angle signal #1 and/or CAN S-bus #2 and crank angle signal #2 missing on FCM-20.			
Procedures	- Make sure that the plug X22 is correctly connected to the related FCM-20.			
	FCM-20 No.	LED	Failure ID	Display
Indication	#01 to #07	S2 and CA2	42	42
Cause	CAN S-bus #1 and crank angle signal #1 and/or CAN S-bus #2 and crank angle signal #2 missing on FCM-20.			
Procedures	- Make sure that the plug X23 is correctly connected to the related FCM-20.			
Failure Text				
ME exhaust valve #nn position meas. fail. (ID 71)				
	FCM-20 No.	LED	Failure ID	Display
Indication	#01 to #08	Ex.D or Ex.F	71	71
Cause	Sensors ZT5421C to 27C (driving end) signal < 2 mA or > 22 mA (failure signal is released after 3 seconds).			
Procedure	⇒ In the related terminal box E95.21 to E95.34 at the cylinder cover, make sure that the plug has no damage and is connected correctly. ⇒ Make sure that the related cables to the sensor and FCM-20 (plug X24, terminals 68 to 72) have no damage and are connected correctly. ⇒ In the related FCM-20 and in the terminal box, make sure that the cables and connections have no damage and are connected correctly. ⇒ If necessary, replace the related sensor. ⇒ If the failure shows at intervals, temporarily disconnect the plug on the terminal box until a repair is possible.			
	FCM-20 No.	LED	Failure ID	Display
Indication	#01 to #08	Ex.D or Ex.F	71	71
Cause	The sensor power supply has a short circuit (red LED).			
Procedure	⇒ Make sure that the related cables to the sensor and the FCM-20 (plug X24, terminals 68 to 72) have no damage and are connected correctly. ⇒ Make sure that the cables and connections in the related FCM-20 and in the terminal box have no damage and are correctly connected. ⇒ If necessary, replace the related sensor. ⇒ If the failure shows at intervals, replace the cable-plug assembly to E95 with the spare. Remark: Temporarily disconnect the plug X24 on the terminal box until a repair is possible.			

Failures and Defects of WECS Components

Failure Text				
WECS module FCM-20 #00 fail. (ID 94)				
	FCM-20 No.	LED	Failure ID	Display
Indication	#00 (E90)	Fail	94	94
Cause	Missing communication on CAN S1 and CAN S2 bus on FCM-20 #00. The remaining FCM-20 in the system on each S-bus did not receive a heartbeat signal from this module.			
Procedure	⇒ Make sure that the FCM-20 #00 is set to on. ⇒ Use a multimeter to do a check of the 24 VDC power supply in E85 and E90. ⇒ If there is a 24 VDC power supply, make sure that the CAN-S bus connections on FCM-20 #00 (plugs X22 and X23, terminals 49 / 50 and plug X23 terminals 57 / 58) are connected correctly. ⇒ If installed, make sure that the terminating resistors (120 ohm) are serviceable. ⇒ Replace the online spare FCM-20 if necessary Remark: If a service computer is connected to CAN M #0, it is possible that there will be no communication. For ID 95 to ID 0.2, see the procedures for ID 94 above.			
Failure Text				
ME crank angle #1 fail. (ID 1.0)				
	FCM-20 No.	LED	Failure ID	Display
Indication	#01 to #08	SSI CA1	110	1.0
Cause	No data received from sensor #1 (GT5126C).			
Procedure	⇒ If the failure is shown on all cylinders do a check of the sensor GT5126C for increased clearance on the sensor pulley and bearings. ⇒ In flexView, do a CAS trend to do a check of the sensor GT5126C. ⇒ Use a multimeter to do a power supply check on the last but one cylinder. ⇒ If there is a power supply, make sure that the connectors in E96 are not damaged and are correctly engaged. ⇒ On FCM-20 #01, do a check of the SSI-bus 120 ohm terminating resistors on the plug X22 (terminals 51/52, 53/54). ⇒ If there are failure indications on a series of FCM-20 without an alarm, do as follows: ⇒ Start at the highest number cylinder that has a failure indication and make sure that the bus cables SSI #1 on all FCM-20 plug X22 (terminals 51/52, 53/54) have no damage and are connected correctly. ⇒ Repair the cables in the related FCM-20. ⇒ If necessary, replace the related FCM-20.			

Failures and Defects of WECS Components

Failure Text				
ME crank angle #2 fail. (ID 1.1)				
	FCM-20 No.	LED	Failure ID	Display
Indication	#01 to #08	SSI CA2	111	1.1
Cause	No data received from sensor #2 (GT5127C).			
Procedure	⇒ If the failure is shown on all cylinders do a check of the sensor GT5127C for increased clearance on the sensor pulley and bearings. ⇒ In flexView, do a CAS trend to do a check of the sensor GT5127C. ⇒ Use a multimeter to do a power supply check on the last but one cylinder. ⇒ If there is a power supply, make sure that the connectors in E96 are not damaged and are correctly engaged. ⇒ On FCM-20 #01, do a check of the SSI-bus 120 ohm terminating resistors on the plug X22 (terminals 51/52, 53/54). ⇒ If there are failure indications on a series of FCM-20 without an alarm, do as follows: ⇒ Start at the highest number cylinder that has a failure indication and make sure that the bus cables SSI #2 on all FCM-20 plug X22 (terminals 51/52, 53/54) have no damage and are connected correctly. ⇒ Repair the cables in the related FCM-20. ⇒ If necessary, replace the related FCM-20.			
Failure Text				
WECS CAN S1-bus fail. (ID 1.2)				
	FCM-20 No.	LED	Failure ID	Display
Indication	#01 to #08	S1	112	1.2
Cause	CAN system bus #1 monitoring / CAN failure (failure signal is released after 3 seconds).			
Procedure	⇒ On the related FCM-20 (plug X22, terminals 49/50), make sure that the cable connections have no damage and are connected correctly. ⇒ Make sure that the S1-bus with 120 ohm resistors on first and last FCM-20 (plug X22) is connected correctly (refer to electrical drawings). ⇒ On the related FCM-20, repair the cable connection / cables. ⇒ If the failure shows on one module only, replace the related FCM-20.			
Failure Text				
WECS CAN S2-bus fail. (ID 1.3)				
	FCM-20 No.	LED	Failure ID	Display
Indication	#01 to #08	S2	113	1.3
Cause	CAN system bus #2 monitoring / CAN failure (failure signal is released after 3 seconds).			
Procedure	⇒ On the related FCM-20 (plug X23, terminals 57/58), make sure that the cable connections have no damage and are connected correctly. ⇒ Make sure that the S2-bus with 120 ohm resistors on first and last FCM-20 plug X23 is connected correctly (refer to electrical drawings). ⇒ On the related FCM-20, repair the cable connection / cables. ⇒ If the failure shows on one module only, replace the related FCM-20.			

Failures and Defects of WECS Components

Failure Text				
ME start pilot valve #nn loop fail. (ID 1.4)				
	FCM-20 No.	LED	Failure ID	Display
Indication	#01 to #08	Start Vlv	114	1.4
Cause	Broken connection or short circuit between FCM-20 and start pilot solenoid valve.			
Procedure	⇒ At the cylinder cover, make sure that the plug in the terminal box E95.41 to E95.48 has no damage and is correctly connected. ⇒ Make sure that the cables between the related solenoid valve and the FCM-20 (plug X15, terminals 33/34) have no damage and are connected correctly. ⇒ Repair the cables and connections between the related solenoid valve and the FCM-20 (plug X15).			
Failure Text				
WECS cylinder lubrication passive failure. (ID 2.5)				
	FCM-20 No.	LED	Failure ID	Display
Indication	#03 and #04		125	2.5
Cause	Disconnected power supply #1 or #2.			
Procedure	⇒ In E85, E90 and E41.xx, make sure that the cables have no damage and are connected correctly. ⇒ In E85, make sure that the all circuit breakers are set to on. ⇒ Repair the cables and connections in E85, E90 (terminals 40/41) and E41.xx (plug X2, terminals 21/22). ⇒ In the FCM-20 (plug X22, terminals 55/56) of the last and last but one cylinders, make sure that the cables and connections have no damage and are connected correctly. ⇒ Do a check of the related ALM-20 CAN-M bus indications (LED CAN 1 or CAN 2). ⇒ If the bus indications show a failure, repair the cables of the last and last but one FCM-20 (plug X22, terminals 55/56). ⇒ Repair the cables in the related CAN-M bus. Make sure that the related ALM-20 operates. ⇒ If after all ALM-20 are started and the related ALM-20 did not start, make sure that the cable address on the plug X1 of the related ALM-20 is connected correctly. ⇒ Do a check of the ALM-20 (plug X1, terminals 16/17) and the related resistors (see 7218-1 Resistor in plug X1, paragraph 5.2). ⇒ Repair the cables and connections in the related ALM-20. ⇒ If necessary, replace the defective ALM-20.			

Failures and Defects of WECS Components

4.6 WECS common failure

Failure Text		ME scavenge air pressure sensor #1+2 meas. fail. (ID 9)			
Indication		FCM-20 No.	LED	Failure ID	Display
		#03 and #04	AI2	9	9
Cause	The two sensor signals are < 2 mA or > 22 mA				
Procedure	⇒ Do a check of the pressure transmitters PT4043C and PT4044C for damage.				
	⇒ In E12, E95.03 and E95.04, use a multimeter to do a check of the 24 VDC supply on the plugs (X27, terminals 94 and 96) and the transmitter plugs (2+/1-).				
	⇒ Do a check of the cables between the pressure transmitters (PT4043C / PT4044C) to E12, E95.03 and E95.04.				
	⇒ If necessary, repair the cables between the pressure transmitters (PT4043C / PT4044C) to E12, E95.03 and E95.04.				
	⇒ If necessary, replace the pressure transmitters PT4043C and PT4044C.				
Indication		FCM-20 No.	LED	Failure ID	Display
		#03 and #04	AI2	9	9
Cause	The sensor power supply has a short circuit (red LED).				
Procedure	⇒ Disconnect the pressure transmitters PT4043 and PT4044C and the plugs X27				
	⇒ Use a multimeter to measure the cables between the plug X27 terminals 94 and 95 and ground for short circuit or ground fault.				
	⇒ Replace damaged cables, or temporarily repair with insulation tape until spares are available.				
	⇒ Measure the transmitters for a ground fault. If necessary, replace the transmitters.				
	⇒ If the failure ID 9 stays on when the plug X27 is disconnected, replace the related FCM-20.				
Failure Text		ME scavenge air pressure meas. fail. diff. high (ID 10)			
Indication		FCM-20 No.	LED	Failure ID	Display
		#03 and #04	AI2	10	10
Cause	The pressure transmitters PT4043C and PT4044C have a difference of more than 0.2 bar (failure signal is released after 5 seconds)				
Procedure	⇒ In the Operator Interface, compare the two scavenge air pressure indications with the pressure gage. This will help you find the pressure transmitter that gives a different signal.				
	⇒ In E12, E95.03 and E95.04, do a check of the cables.				
	⇒ Adjust the applicable pressure transmitter, or replace it if necessary.				

Failures and Defects of WECS Components

Failure Text				
ME servo oil pressure sensor #1+#2 meas. fail. (ID 17)				
	FCM-20 No.	LED	Failure ID	Display
Indication	#01 and #02	AI2	17	17
Cause	The two sensor signals are less than 2 mA or more than 22 mA (failure signal is released after 3 seconds).			
Procedure	⇒ On the servo oil rail, do a check of the pressure transmitters PT2071C and PT2072C for damage. ⇒ Do a check of the 24 VDC supply on the plugs X27 (terminals 94+/96-) in E95.01 and E95.02 and on the transmitter plugs. ⇒ If there is a 24 VDC supply, do a check of the cables to E95.01 and E95.02. ⇒ Repair or replace damaged cables between the pressure transmitter and E95.01 or E95.02. ⇒ Use a multimeter to do a check of the sensor signal (X27 terminal 95). ⇒ Replace a minimum of one pressure transmitter immediately.			
	FCM-20 No.	LED	Failure ID	Display
Indication	#01 and #02	AI2	17	17
Cause	The sensor power supply has a short circuit (red LED)			
Procedure	⇒ Disconnect the pressure transmitters PT2071C and PT2072C and the plugs X27 ⇒ Use a multimeter to do a check between each of the cables on the plugs X27 terminals 94 and 95 and ground for a short circuit or ground fault. ⇒ Replace damaged cables, or temporarily repair with insulation tape until spares are available. ⇒ Do a check of the transmitters for a ground fault. If necessary, replace the pressure transmitter(s). ⇒ If failure ID 17 stays on when the plug X27 is disconnected, replace the related FCM-20.			
Failure text				
ME servo oil pressure meas. fail. diff. high (ID 18)				
	FCM-20 No.	LED	Failure ID	Display
Indication	#01 and #02	AI2	18	18
Cause	The pressure transmitters PT2071C and PT2072C have a difference of more than 30 bar (failure signal is released after 7 seconds).			
Procedures	⇒ Compare the two servo oil pressure indications. ⇒ With the engine stopped and no pressure in the servo oil rail, find the pressure transmitter that gives the different signal. ⇒ If possible, change the engine load through a wider range and find the pressure transmitter that does not follow linearly to the change in the servo oil pressure. ⇒ Do a check of the cabling in E95.01 and E95.02 of the pressure transmitter that gives the different signal (plug X27, terminals 94/95). ⇒ Repair or replace damaged cables. ⇒ Replace the pressure transmitter PT2071C or PT2072C.			

Failures and Defects of WECS Components

Failure text				
ME servo oil pressure high (ID 19)				
	FCM-20 No.	LED	Failure ID	Display
Indication	#01 and #02	AI2	19	19
Cause	Servo oil pressure is 15 bar more than the setpoint, engine speed is more than 8% of nominal speed (failure signal is released after 5 seconds). Remark: No failure is shown during the conditions that follow: Slow turning, air run and control oil meas. fail. Pressure controllers were not adjusted in the servo oil pumps after an overhaul. Dirt particles prevent the function of a pressure controller.			
Procedures	⇒ Clean / adjust the pressure controllers in servo oil pumps.			
Failure Text				
ME servo oil pressure low (ID 20)				
	FCM-20 No.	LED	Failure ID	Display
Indication	#01 and #02	AI2	20	20
Cause	Servo oil pressure is 15 bar less than the setpoint. The engine speed is more than 8% of nominal speed (failure signal is released after 10 seconds). Remark: No failure is shown during the conditions that follow: Slow turning, air run, shut-down and servo oil pressure very low, control oil meas. fail.			
Procedure	⇒ Do a check of the oil pressure downstream of the automatic filter. ⇒ Do a check of the control signals and cables to the servo oil pumps for correct connections and / or damage. ⇒ Repair or replace damaged cables. ⇒ Make sure that the safety valve 4.23 open. ⇒ The pump drive shaft 4.50 is broken (pump temperature low, no vibrations) or the pump is defective. ⇒ The HP pipes have leaks between the collector block and the servo oil rail. Do a check for a leakage alarm. ⇒ Repair the leaks. ⇒ If necessary, replace the related pressure controller (CV7221C, CV7222C, CV7223C). Remark: In dangerous conditions, temporarily set to off the injection and exhaust valve operation on cylinder 1 or 2 to increase the servo oil pressure. Attention: Do not set the cylinders to off in their firing order sequence. Do not operate the engine at or near the barred speed range.			
Failure Text				
ME servo oil pump #1 fail. (ID 26)				
	FCM-20 No.	LED	Failure ID	Display
Indication	#03	PWM	26	26
Cause	The setpoint pressure controller of the servo oil pump actuator CV7221C is more than 100 mA (failure signal is released after 30 seconds).			
Procedure	⇒ In E85, set the FCM-20 #03 to off. ⇒ Do a check of the connection on the servo oil pump actuator CV7221C. ⇒ If necessary, replace the cables and connections. ⇒ Make sure that the cables and connections between pump #1 and E95.03 are correct. ⇒ If necessary, replace the servo oil pump actuator CV7221C. ⇒ In E85, set the FCM-20 #03 to on.			

Failures and Defects of WECS Components

Failure Text				
ME servo oil pump #2 fail. (ID 26)				
	FCM-20 No.	LED	Failure ID	Display
Indication	#04	PWM	26	26
Cause	The setpoint pressure controller of the servo oil pump actuator CV7222C is more than 100 mA (failure signal is released after 30 seconds).			
Procedure	⇒ In E85, set the FCM-20 #04 to off ⇒ Do a check of the connection on the servo oil pump actuator CV7222C ⇒ If necessary, replace the cables and connections ⇒ Make sure that the cables and connections between pump #2 and E95.04 is correct ⇒ If necessary, replace the pressure controller CV7222C ⇒ Set the FCM-20 #04 to on			
Failure Text				
ME servo oil pump #3 fail. (ID 26)				
	FCM-20 No.	LED	Failure ID	Display
Indication	#05	PWM	26	26
Cause	The setpoint pressure controller of the servo oil pump actuator CV7223C is more than 100 mA (failure signal is released after 30 seconds).			
Procedure	⇒ In E85, set the FCM-20 #05 to off. ⇒ Do a check of the connection on the servo oil pump actuator CV7223C. ⇒ If necessary, replace the cables and connections. ⇒ Make sure that the cables and connections between pump #3 and E95.05 are correct. ⇒ If necessary, replace the servo oil pump actuator CV7223C. ⇒ In E85, set the FCM-20 #05 to on.			

Failures and Defects of WECS Components

Failure Text		ME fuel rail pressure sensor #1+#2 meas. fail. (ID 28)			
Indication		FCM-20 No.	LED	Failure ID	Display
		#03 and #04	AI1	28	28
Cause	The two sensor signals of PT3461C and PT3462C are less than 2 mA or more than 22 mA (failure signal is released after 3 seconds).				
Procedure	⇒ On the fuel rail, do a check of the pressure transmitters PT3461C and PT3462C for damage.				
	⇒ Use a multimeter to do a check of the 24 VDC supply on the plugs (X25, terminal 79 and ground) and the cables to E95.03 and E95.04 and on the transmitter plugs (2+ / 1-).				
	⇒ If there is a power supply, do a check of the the cables for damage between the pressure transmitters and E95.03 and E95.04.				
	⇒ Repair or replace damaged cables.				
	⇒ Replace a minimum of one pressure transmitter immediately.				
Failure Text		ME fuel rail pressure meas. fail. diff. high (ID 29)			
Indication		FCM-20 No.	LED	Failure ID	Display
		#03 and #04	AI2	28	28
Cause	The sensor power supply has a short circuit (red LED)				
Procedure	⇒ Disconnect the pressure transmitters PT 3461C and PT3462C and the plugs X25				
	Remark: ID failure 33 on FCM-20 #03 and #04 will be shown				
	⇒ Use a multimeter to do a check between each of the cables on plug X25 terminals 79 and 80 and ground for a short circuit or ground fault.				
	⇒ Replace damaged cables or temporarily repair with insulation tape until spares are available.				
	⇒ Do a check of the transmitters for a ground fault. If necessary, replace the pressure transmitter(s).				
⇒ If the red LED stays on when the plug X25 is disconnected, replace the related FCM-20.					
Failure Text		ME fuel rail pressure meas. fail. diff. high (ID 29)			
Indication		FCM-20 No.	LED	Failure ID	Display
		#03 and #04	AI1	29	29
Cause	The sensors PT3461C and PT3462C have a difference of more than 50 bar (failure signal is released after 7 seconds).				
Procedure	⇒ Compare each of the two pressure indications of the fuel rail.				
	⇒ With the engine stopped and no pressure in the fuel rail, find the pressure transmitter that gives the different signal.				
	⇒ If possible, change the engine load through a wider range and find the pressure transmitter that does not follow linearly to the change in the fuel pressure.				
	⇒ Do a check of the cables of the pressure transmitter that gives the different signal (plug X25, terminal 79/80).				
	⇒ Repair or replace damaged cables on the pressure transmitter that gives the different signal.				
⇒ If necessary, replace the applicable pressure transmitter.					

Failures and Defects of WECS Components

Failure Text		ME fuel rail pressure high (ID 30)			
Indication		FCM-20 No.	LED	Failure ID	Display
		#03 and #04	AI1	30	30
Cause	The measured fuel rail pressure is 50 bar more than the fuel pressure set point (failure signal is released after 10 seconds). Remark: No failure when the engine has stopped.				
Procedure	⇒ Make sure that the toothed rack can move freely. ⇒ Make sure that the fuel pump actuators are set to on and operate correctly. ⇒ Do a check for actuator alarms in the AMS. ⇒ Make sure that during engine operation and when the engine has stopped, all actuators are at the same position. ⇒ Make sure that the all actuators are at zero supply when the actuator output is 0%. ⇒ Adjust the toothed racks to get the correct clearances at the minimum / maximum position. ⇒ Replace the defective fuel pump actuator(s). Remark: An alarm can show if the engine is started and stopped again and again without a fuel injection release in between.				
Failure Text		ME fuel rail pressure low (ID 31)			
Indication		FCM-20 No.	LED	Failure ID	Display
		#03 and #04	AI1	31	31
Cause	Fuel rail pressure is 100 bar less than the fuel pressure setpoint (failure signal is released after 10 seconds). Remark: No failure shown during the conditions that follow: No engine operation, no start command, fuel rail pressure very low				
Procedure	⇒ Make sure that the toothed rack can move freely. ⇒ Make sure that the fuel pump actuators are set to on and operate correctly. ⇒ Do a check of the actuator alarms in the AMS (alarms can show mechanical problems). ⇒ Make sure that the fuel supply pressure is between 7 bar to 10 bar and the pressure downstream from the pressure retaining valve is 3 bar to 5 bar. ⇒ Do a check for leakage alarms. ⇒ Make sure that there is an oil supply to the fuel pressure control valve 3.06. Make sure that the valve seat can move. ⇒ Examine the fuel pressure control valve 3.06 for leaks (if the fuel pressure control valve has a leak, you can hear a loud noise like a whistle). ⇒ The fuel overpressure safety valve 3.52 has a leak. ⇒ Do a check for damage on the non-return valves 3.22, 3.81-1 and 3.81-2 in the fuel pump covers. ⇒ Adjust the toothed racks to the correct clearances at the minimum / maximum positions. ⇒ If necessary, replace the fuel pump actuators. ⇒ Repair all the leaks in the system. ⇒ Replace the defective valves. ⇒ Grind the sealing surfaces on the HP fuel pipes between the fuel pump and the fuel rail if leaks are found, or isolate the pipe(s) temporarily until a repair is possible.				

Failures and Defects of WECS Components

Failure Text		ME crank angle difference between #1 and #2 (ID 60)			
Indication		FCM-20 No.	LED	Failure ID	Display
		#01 and #02	SSI CA1	60	60
Cause	Crank angle sensor #1 and #2 are serviceable, but the difference between the two systems is more than 1.0° CA.				
Procedures	<ul style="list-style-type: none"> - Do a check of the toothed belt for tension and / or movement. - When the flywheel is at TDC of Cyl. 1, the two sensors must show 0° CA (in the Operator Interface). - Adjust the offset parameter in flexView or the belt position on the sensor drive unit. - Stop the engine, then use the turning gear to get a crank angle sensor trend in flexView. - Make sure that the two trend lines for CAS#1 and CAS #2 are parallel. - Replace the defective crank angle sensor. 				
Failure text		ME TDC signal fail. (ID 62)			
Indication		FCM-20 No.	LED	Failure ID	Display
		#05	BI1	62	62
Cause	No TDC signal from pick-up ZS5123C (failure signal is released after 10 seconds).				
Procedure	<ul style="list-style-type: none"> ⇒ Do a check of the cables between the pick-up ZS5123C and E95.05. ⇒ Make sure that the distance between the pick-up and the flywheel tooth is correct. ⇒ Do a check of the supply voltage and signal between the pick-up ZS5123C and E95.05 (plug X27, terminals 89/90/91). ⇒ Repair or replace damaged cables between the pick-up ZS5123C and E95.05. ⇒ If necessary, adjust the distance between the pick-up and the flywheel tooth. ⇒ If necessary, replace the pick-up. ⇒ Make sure that the target on the flywheel is correctly installed. ⇒ For emergency operation, disconnect the TDC pick-up temporarily if the pick-up fault prevents engine operation. 				
Indication		FCM-20 No.	LED	Failure ID	Display
		#05	BI1	62	62
Cause	The sensor power supply has a short circuit (red LED).				
Procedure	<ul style="list-style-type: none"> ⇒ In E95.05, disconnect the TDC pick-up ZS5123C and plug X27. ⇒ Use a multimeter to do a check between each of the cables on plug X27 terminals 89 and 90 and ground for a short circuit or ground fault. ⇒ Replace damaged cables or temporarily repair with insulation tape until spares are available. ⇒ Do a check of the pick-up ZS5123C for a ground fault. Replace the pick-up ZS5123C if necessary. ⇒ If failure ID 62 stays on when the plug X27 is disconnected, replace FCM-20 #05 				

Failures and Defects of WECS Components

Failure Text		ME crank angle #1 / TDC high shift (ID 63)			
Indication		FCM-20 No.	LED	Failure ID	Display
		#05	BI1	63	63
Cause	The difference between the TDC pick-up and the crank angle sensor #1 is 4.0° CA The crank angle sensor or toothed belt has moved.				
	Remark: No failure shown at shut-down				
Procedure	⇒ Do a check for an incorrect TDC offset adjustment in flexView.				
	⇒ Adjust to get the correct distance between the pick-up and the flywheel tooth (4 mm).				
	⇒ Do a check of the crank angle sensor drive.				
	⇒ Make sure that the CAS#1 is in the correct position (at TDC #1).				
	⇒ Do a check of the belt condition.				
	⇒ Do a check of the crank angle sensor offset adjustment in flexView.				
	⇒ Do a CAS trend in flexView.				
	⇒ If necessary, replace CAS #1.				
Failure Text		ME crank angle #1 / TDC high shift (ID 63)			
Indication		FCM-20 No.	LED	Failure ID	Display
		#05	BI1	63	63
Cause	The difference between the TDC pick-up and the crank angle measurement system #1 is 4.0° CA. The crank angle sensor or toothed belt has moved.				
Procedure	⇒ Do a check for an incorrect TDC offset adjustment in flexView.				
	⇒ Adjust to get the correct distance between the pick-up and the flywheel tooth (4 mm).				
	⇒ Stop the engine, then use the turning gear and do a CAS trend in flexView.				
	⇒ Make sure that each trend line for CAS#1 and CAS#2 is the same.				
Failure text		ME crank angle #2 / TDC high shift (ID 64)			
Indication		FCM-20 No.	LED	Failure ID	Display
		#05	BI1	64	64
Cause	The difference between the TDC pick-up and the crank angle sensor #1 is 4.0° CA. The crank angle sensor or toothed belt has moved				
	Remark: No failure shown at shut-down				
Procedure	⇒ Do a check for an incorrect TDC offset adjustment in flexView.				
	⇒ Adjust the get the correct distance between the pick-up and the flywheel tooth (4 mm).				
	⇒ Do a check of the crank angle sensor drive.				
	⇒ Make sure that the CAS#2 is in the correct position (at TDC #1).				
	⇒ Do a check of the belt condition.				
	⇒ Do a check of the crank angle sensor offset adjustment in flexView.				
	⇒ Do a CAS trend in flexView.				
	⇒ If necessary, replace CAS #2				

Failures and Defects of WECS Components

Failure Text				
ME crank angle #2 / TDC high shift (ID 64)				
	FCM-20 No.	LED	Failure ID	Display
Indication	#05	BI1	64	64
Cause	The difference between the TDC pick-up and the crank angle measurement system #2 is 4.0° CA. The crank angle sensor or toothed belt has moved.			
Procedure	⇒ Do a check for an incorrect TDC offset adjustment in flexView. ⇒ Adjust to get the correct distance between the pick-up and the flywheel tooth (4 mm). ⇒ Stop the engine, then use the turning gear and do a CAS trend in flexView. ⇒ Make sure that each trend line for CAS#1 and CAS#2 is the same.			
Failure Text				
ME crank angle #1 / TDC low shift (ID 66)				
	FCM-20 No.	LED	Failure ID	Display
Indication	#05	BI1	66	66
Cause	Tolerance is $> \pm 2.0^\circ$ Crank angle sensor or toothed belt has moved Remark: No failure shown at shut-down			
Procedures	⇒ Do a check for an incorrect TDC offset adjustment ⇒ Do a check for possible crankshaft movement ⇒ Adjust to get the correct distance of the TDC pickup to the flywheel tooth ⇒ If necessary, adjust the offset parameter or belt position			
Failure Text				
ME crank angle #2 / TDC low shift (ID 67)				
	FCM-20 No.	LED	Failure ID	Display
Indication	#05	BI1	67	67
Cause	The difference between the TDC pick-up and the crank angle sensor #2 is $\pm 2.0^\circ$ The crank angle sensor or toothed belt has moved Remark: No failure shown at shut-down			
Procedure	⇒ Do a check for an incorrect TDC offset adjustment in flexView. ⇒ Adjust to get the correct distance between the pick-up and the flywheel tooth (4 mm). ⇒ Do a check of the crank angle sensor drive. ⇒ Make sure that the CAS#2 is in the correct position (at TDC #1). ⇒ Do a check of the belt condition. ⇒ Do a check of the crank angle sensor offset adjustment in flexView. ⇒ Do a CAS trend in flexView. ⇒ If necessary, replace CAS #2.			

Failures and Defects of WECS Components

Failure Text				
ME crank angle #2 / TDC low shift (ID 67)				
	FCM-20 No.	LED	Failure ID	Display
Indication	#05	BI1	67	67
Cause	The difference between the TDC pick-up and the crank angle measurement system is #2 is $\pm 2.0^\circ$. The crank angle sensor or toothed belt has moved			
	Remark: No failure shown at shut-down			
Procedure	⇒ Do a check for an incorrect TDC offset adjustment in flexView. ⇒ Do a check of the crank angle sensor offset adjustment in flexView. ⇒ Adjust to get the correct distance between the pick-up and the flywheel tooth (4 mm). ⇒ Stop the engine, then use the turning gear and do a CAS trend in flexVlew. ⇒ Make sure that each trend line for CAS#1 and CAS#2 is the same.			
Failure Text				
ME injection quantity sensor #nn meas. fail. (ID 80)				
	FCM-20 No.	LED	Failure ID	Display
Indication	#01 to #09	InjQ	80	80
Cause	Sensor signal ZT5461C to ZT5468C is less than 2 mA or more than 22 mA (failure signal is released after 3 seconds)			
Procedure	⇒ Make sure that the the cables to the related fuel quantity sensor have no damage and are connected correctly. ⇒ Make sure that the plug is correctly engaged with the socket. ⇒ Make sure that the measurement sleeve is correctly installed on the fuel quantity piston ⇒ Make sure that the cables between the related FCM-20 and the fuel quantity sensor have no damage and are connected correctly. ⇒ If the feedback is not stable, replace the sensor or disconnect the plug temporarily if there are no spares available.			
Failure Text				
ME injection quantity sensor #nn meas. fail. (ID 80)				
	FCM-20 No.	LED	Failure ID	Display
Indication	#01 to #09	InjQ	80	80
Cause	The sensor power supply has a short circuit (red LED).			
Procedure	⇒ Disconnect the fuel quantity sensor and the plug X26. Remark: CA sensor failure ID 57 or 58 if FCM-20 # is the last cylinder, or last but one cylinder. ⇒ Use a multimeter to do a check between each of the cables on the plug X26 terminals 86 and 87 and ground (terminal 88) for short circuit or ground fault. ⇒ Replace damaged cables or temporarily repair with insulation tape until spares are available. ⇒ If necessary, replace the fuel quantity sensor. ⇒ If failure ID 80 stays on when the plug X26 is disconnected, replace the related FCM-20.			

Failures and Defects of WECS Components

Failure Text				
ME Inj. Time Too Short (ID 87)				
	FCM-20 No.	LED	Failure ID	Display
Indication	#01 to #08	InjQ	87	87
Cause	Injection timing failure (injection time is less than 60% of the set time)			
Procedure	⇒ Make sure that the rail valve is serviceable. ⇒ If the rail valve is serviceable, do a check of the opening pressure of the injector valve. ⇒ If the opening pressure is correct, make sure that the injection nozzle is not defective. ⇒ If the injection nozzle is serviceable, examine the injector pipes for leaks.			
Failure Text				
ME Inj. Time Too Long (ID 88)				
	FCM-20 No.	LED	Failure ID	Display
Indication	#01 to #08	InjQ	88	88
Cause	Injection timing failure (injection time is more than 150% of the set time)			
Procedure	⇒ Make sure that the rail valve is serviceable. ⇒ If the rail valve is serviceable, make sure that the injectors are not blocked. ⇒ If the injectors are not blocked, do a check of the opening pressure of the injector valve. ⇒ Make sure that all injectors operate correctly. Remark: This failure can occur during fast load changes when the engine operates in rough sea.			
Failure Text				
ME injection timing fail. cylinder #nn (ID 89)				
	FCM-20 No.	LED	Failure ID	Display
Indication	#01 to #08	None	89	89
Cause	Injection timing failure			
Procedure	⇒ The cause of this failure is the failure 87 or 88. For more data, see the related failure ID 87 and ID 88 above.			
Failure Text				
ME exhaust waste gate not closed (ID 5.5)				
	FCM-20 No.	LED	Failure ID	Display
Indication	#01	InjQ	155	5.5
Cause	Butterfly valve stays open at a load range of less than 85%. Connection to the position sensor ZS5372C is broken, or there is a short circuit (failure signal released after 20 seconds)			
Procedure	⇒ Use flexView to do a check of the waste gate position. Make sure that the flexView card ExhWgt, para Waste Gate Position shows Not Closed. ⇒ Make sure that there is an air supply to the position sensor ZS5372C. ⇒ Between FCM-20 #01 (plug X27, terminals 89 / 90) and position sensor ZS5372C, make sure that the cables have no damage and are connected correctly. ⇒ If necessary, repair or replace damaged cables. ⇒ Do a check of the mechanical part of the waste gate. ⇒ If necessary, replace the position sensor ZS5372C. ⇒ For more data, see 0820-1 , paragraph 5 Exhaust waste gate.			

Failures and Defects of WECS Components

Failure Text				
ME exhaust waste gate not open (ID 5.6)				
	FCM-20 No.	LED	Failure ID	Display
Indication	#05	InjQ	156	5.6
Cause	Butterfly valve stays closed at a load range of more than 85%. Connection to the solenoid valve ZV7076C is broken, or there is a short circuit (failure signal released after 20 seconds).			
Procedure	⇒ Decrease engine power. ⇒ Between FCM-20 #05 (plug X15 terminals 39 / 40) and the solenoid valve ZV7076C, make sure that the cables have no damage and are connected correctly. ⇒ If necessary, repair or replace damaged cables. ⇒ Make sure that the butterfly valve operates correctly (see 8135-1, paragraph 3 Function check). ⇒ If necessary, replace the butterfly valve and / or the solenoid valve ZV7076C. ⇒ For more data, see 0820-1, paragraph 5 Exhaust waste gate.			
Failure Text				
ME scavenge air pressure high (ID 5.7)				
	FCM-20 No.	LED	Failure ID	Display
Indication	#05	InjQ	157	5.7
Cause	Exhaust waste gate has a malfunction(engines with LLT during high of more than 85%). Scavenge air pressure is more than 105% of the CMCR setting. Cable between FCM-20-#05 is broken, or there is a short circuit (failure signal released after 2 seconds)			
Procedure	⇒ Decrease engine power. ⇒ Make sure that the waste gate operates correctly. ⇒ Between FCM-20 #05 and the solenoid valve ZV7076C, make sure that the cables have no damage and are connected correctly. ⇒ If necessary, repair or replace damaged cables. ⇒ Make sure that the butterfly valve operates correctly (see 8135-1, paragraph 3 Function check). ⇒ If necessary, replace the butterfly valve and / or the solenoid valve ZV7076C. ⇒ For more data, see 0820-1, paragraph 5 Exhaust waste gate. Remark: It is possible that this failure is related to Failure ID 156.			

Failures and Defects of WECS Components

4.7 WECS cylinder failure

Failure Text				
ME manual injection cutoff cylinder #nn (ID 45)				
	FCM-20 No.	LED	Failure ID	Display
Indication	#01 to #08		45	45
Cause	The fuel injection is cut off manually			
Procedure	⇒ For more data, see the related alarms (WECS cylinder fail) Remark: This failure is not shown if a cylinder is cut off automatically.			
Failure Text				
ME both CA / TDC low shift (ID 68)				
	FCM-20 No.	LED	Failure ID	Display
Indication	#05	BI1	68	68
Cause	The difference between the TDC pick-up (measured angle) and CA sensor #1 and CA sensor #2 is $\pm 2^\circ$.			
Procedure	⇒ Do a check for an incorrect TDC offset adjustment. ⇒ Adjust to get the correct distance between the pick-up and the flywheel tooth (4 mm). ⇒ Do a check for possible crankshaft movement. ⇒ Make sure that the CAS#1 and CAS#2 are in the correct position (at TDC #1). ⇒ Do a check of the belt condition. ⇒ Do a check of the crank angle sensor offset adjustment in flexView. ⇒ Do a CAS trend in flexView. ⇒ If each of the two CAS are defective, replace a minimum of one CAS. ⇒ Adjust the offset parameter or the belt position as necessary (see the Maintenance Manual 9223-1). Remark: The measured offset in flexView changes in relation to the engine speed. Do not adjust the offset to zero at full engine speed, because this can activate this failure at higher ASTERN revolutions.			
Failure Text				
ME Exh. Valve Late/Not Opening (slowdown) (ID 75)				
	FCM-20 No.	LED	Failure ID	Display
Indication	#01 to #08		75	75
Cause	The exhaust valve opens 15° CA or more after the crank angle setpoint.			
Procedure	⇒ Do a check of the ON times of the rail valve 4.76. ⇒ Make sure that the cables between the rail valve 4.76 and the related FCM-20 have no damage and are correctly connected. ⇒ If the failure is shown for all cylinders, do the checks that follow: ⇒ Do a check of the the air spring pressure. Make sure that the pressure is not too high. ⇒ In the Valve Control Unit (VCU), do a check of the non-return valve of the oil supply to the hydraulic pipe 4.66. ⇒ Do an internal check of the VCU 4.10 for a mechanical failure. ⇒ Make sure that the hydraulic piston in the exhaust valve drive 4.03 moves freely. ⇒ Do a check of the related FCM-20. ⇒ Repair or replace damaged cables between the rail valve and the related FCM-20. ⇒ If necessary, replace the related FCM-20, VCU 4.10, rail valve 4.76, exhaust valve drive 4.03 or non-return valve 4.06.			

Failures and Defects of WECS Components

Failure Text				
ME Exh. Valve Early Closing (slowdown) (ID 76)				
	FCM-20 No.	LED	Failure ID	Display
Indication	#01 to #08		76	76
Cause	The exhaust valve closes 10° CA or more before the crank angle setpoint.			
Procedure	⇒ Do a check of the air spring pressure. Make sure that the pressure is not too high. ⇒ Do a check of the non-return valve in the VCU 4.10. ⇒ Make sure that the orifice in the VCU is not blocked. ⇒ Do an internal check of the VCU for mechanical failure. Replace the VCU with the adjacent VCU to find the cause of the malfunction. ⇒ Do a check for leaks in the hydraulic system (hydraulic pipes etc). ⇒ Do a check of the related FCM-20. ⇒ If necessary, replace the related FCM-20.			
Failure Text				
ME Exh. Valve Late/Not Closing (slowdown) (ID 77)				
	FCM-20 No.	LED	Failure ID	Display
Indication	#01 to #08		77	77
Cause	The exhaust valve closes 15° CA or more after the crank angle setpoint			
Procedure	⇒ Do a check of the ON times of the rail valve 4.76. ⇒ Make sure that the cables between the rail valve 4.76 and the related FCM-20 have no damage and are correctly connected. ⇒ Do a check of the the air spring pressure. Make sure that the pressure is not too low. ⇒ Make sure that the non-return valve 4.06 is serviceable. ⇒ Do an internal check of the VCU 4.10 for mechanical failure. ⇒ Make sure that the piston in the exhaust valve drive 4.03 moves freely. ⇒ Do a check of the FCM-20. ⇒ If necessary, replace the FCM-20, VCU 4.10, rail valve 4.76, exhaust valve drive 4.03 or non-return valve 4.06.			
Failure Text				
ME exhaust valve #nn fail. (ID 78)				
	FCM-20 No.	LED	Failure ID	Display
Indication	#01 to #08	None	78	78
Cause	The exhaust valve does not open / close at the WECS setpoint.			
Procedure	⇒ The cause of this failure is the failure 75, 76 or 77. For more data, see the related failure IDs.			
Failure Text				
ME Inj. Quantity Piston, Late / No Return (ID 90)				
	FCM-20 No.	LED	Failure ID	Display
Indication	#01 to #08	ExD	90	90
Cause	The fuel quantity piston does not go back to its initial position after the injection. (failure signal released after 30 seconds).			
Procedure	⇒ Do a check of the sensor signal from the fuel quantity piston. If the signal is not below 5.5 mA after the injection, the piston did not go back to its initial position. ⇒ Make sure that the fuel viscosity and temperature is in the permitted range. ⇒ Do a check of the trace heating system. Remark: If the vessel operates in rough sea, this failure can occur during fast load changes.			

Failures and Defects of WECS Components

Failure Text				
ME Inj. Quantity Piston, No Movement (slowdown) (ID 91)				
	FCM-20 No.	LED	Failure ID	Display
Indication	#01 to #08	InjQ	91	91
Cause	The fuel quantity piston moves less than 4% during the injection. Remark: This alarm is first transmitted after the engine has turned three times.			
Procedure	Remark: If the engine operates at very low load, this alarm usually occurs because of the small fuel quantity. ⇒ Do a check of the rail valve. ⇒ Make sure that the fuel viscosity is in the permitted range. ⇒ Make sure that the fuel quantity piston moves freely. Remark: If the vessel operates in rough sea, this failure can occur during fast load changes.			
Failure Text				
ME Inj. Quantity Piston, Stuck In Max. Pos. (Inj.cut-off+SLD) (ID 92)				
	FCM-20 No.	LED	Failure ID	Display
Indication	#01 to #08	None	92	92
Cause	Sensor signal is more than 18 mA. The fuel quantity piston makes a fuel stroke because the return command is not transmitted correctly.			
Procedure	⇒ Do a check of the rail valve position. ⇒ If the rail valve stays in the inject position, do a check of the injection control valve. ⇒ If the injection control valve stays in the open position, make sure that the oil return pipe is not clogged or closed. ⇒ Make sure that the fuel viscosity is in the permitted range. ⇒ Examine the fuel injectors and pipes for leaks.			
Failure Text				
ME injection quantity piston fail. cylinder #nn (ID 93)				
	FCM-20 No.	LED	Failure ID	Display
Indication	#01 to #08	InjQ	93	93
Cause	The injection quantity piston is defective.			
Procedure	⇒ The cause of this failure is related to failure 90, 91 or 92. For more data, see the related failure ID.			
Failure Text				
WECS module FCM-20 #nn fail. (ID 95 to 0.2)				
	FCM-20 No.	LED	Failure ID	Display
Indication	#01 to #nn	Fail	95 to 102	95 to 0.2
Cause	Missing communication on Can S1 and S2 bus on FCM #nn. Remaining FCM-20 received no heartbeat signal from this FCM-20 (failure signal is released after 12 seconds)			
Procedure	⇒ Do a check of the related LED on the FCM-20 #nn. ⇒ If the red LED comes on, do a check of the cables on the related FCM-20 and the plugs X22 and X23 for correct connections and / or damage. ⇒ Do a check of the terminating resistor on FCM-20 #01 and the FCM-20 on the last cylinder (or the on-line spare FCM-20 #00) plug X22 between terminals 49/59 and plug X23 terminals 57/58. ⇒ If the terminating resistors are serviceable, repair or replace damaged cables. ⇒ if the failure occurs on one module only, replace the related FCM-20 with the online spare.			

Failures and Defects of WECS Components

4.8 WECS pressure failure

Failure Text		ME Scavenge Air Pressure very HI (ID 11)			
Indication		FCM-20 No.	LED	Failure ID	Display
		#03 and #04	AI2	11	11
Cause	<p>The scavenge air pressure is more than 105% (failure signal is released after 2 seconds). The exhaust waste gate has a malfunction.</p> <p>Remark: No failure is shown during the conditions that follow: Shut-down, stop command, scavenge air pressure sensor #1+2 meas. fail.</p>				
Procedure	<p>⇒ Decrease engine power.</p> <p>⇒ For the correct procedures, see the data given in the manual of turbocharger manufacturer</p> <p>⇒ Do a check of the cables between the FCM20#5 and solenoid valve ZV7076C for correct connections and / or damage.</p> <p>⇒ Repair or replace damaged cables.</p> <p>⇒ If the cables are serviceable, do a function check of the butterfly valve (see 8135-1 Exhaust Waste Gate, paragraph 3).</p> <p>⇒ If necessary, replace the butterfly valve or solenoid valve ZV7076C.</p>				
Failure Text		ME servo oil pressure very low (ID 21)			
Indication		FCM-20 No.	LED	Failure ID	Display
		#01 and #02	AI2	21	21
Cause	<p>The servo oil pressure is 50 bar less than the setpoint. The engine speed is more than 8% of the nominal speed (failure signal is released after 5 seconds).</p> <p>Remark: No failure is shown during the conditions that follow: Shut-down, stop command, air run, slow turning, servo oil pressure sensor #1+2 meas. fail.</p>				
Procedure	<p>⇒ Do a check of the oil filter downstream of the automatic filter.</p> <p>⇒ Do a check of the control signals and cables to the servo oil pumps for correct connections and / or damage.</p> <p>⇒ Repair or replace damaged cables.</p> <p>⇒ Make sure that the safety valve 4.23 is open.</p> <p>⇒ Make sure that the pump drive shaft 4.50 is serviceable.</p> <p>⇒ Make sure that the servo oil pumps are serviceable (e.g. have no vibration).</p> <p>⇒ Do a check for leaks between the collector block and the servo oil rail (leakage alarm).</p> <p>⇒ If necessary, repair the leaks.</p> <p>⇒ If necessary, replace the related pressure controller (CV7221C, CV7222C, CV7223C).</p> <p>Remark: In dangerous conditions, you can temporarily set to off the injection and exhaust valve operation on cylinders 1 or 2 to increase the servo oil pressure.</p> <p>Attention: Do not set the cylinders to off in their firing order sequence. Do not operate the engine at or near the barred speed range.</p>				

Failures and Defects of WECS Components

Failure Text	ME fuel rail pressure very low (ID 32)			
	FCM-20 No.	LED	Failure ID	Display
Indication	#03 and #04	AI1	32	32
Cause	<p>The fuel rail pressure is 150 bar more than the fuel pressure setpoint (failure signal is released after 10 seconds)</p> <p>Remark: No failure is shown during the conditions that follow: Stop command, shut-down, engine is stopped, fuel rail pressure sensor #1+2 meas. fail.</p>			
Procedure	<ul style="list-style-type: none"> ⇒ Make sure that the fuel pump actuators are set to on and operate correctly. ⇒ Make sure that the toothed racks can move freely. ⇒ In the AMS, do a check of the actuator alarms. ⇒ Make sure that the fuel supply pressure is between 7 bar and 10 bar. ⇒ Make sure that downstream from the pressure retaining valve 3.53, the pressure is between 3 bar and 5 bar. ⇒ Do a check for leakage alarms. ⇒ Make sure that there is oil supply to fuel pressure control valve 3.06. Make sure that the valve seat can move. ⇒ Examine the fuel pressure control valve 3.06 for leaks (if the fuel pressure control valve has a leak, you can hear a loud noise like a whistle). ⇒ On the fuel pump outlet pipes (TE3431A to TE3434A), do a check of the temperature. ⇒ On the fuel overpressure safety valve 3.52, do a check for leaks. ⇒ Do a check for damage on the non-return valves 3.22, 3.81-1 and 3.81-2. ⇒ Fuel pump plunger cannot move (fuel pump does not supply fuel) ⇒ Adjust the toothed racks to the correct clearances at the minimum / maximum positions. ⇒ If the fuel pump actuators, replace them. ⇒ Repair the leaks. ⇒ Replace the defective valves. ⇒ Grind the sealing surfaces on the HP fuel pipes between the fuel pump and the fuel rail if leaks are found, or isolate the pipe(s) temporarily until a repair is possible. 			

Failures and Defects of WECS Components

4.9 WECS critical failure (WECS engine failure)

Failure Text				
ME crank angle #1+2 fail. (ID 1)				
Indication	FCM-20 No.	LED	ID	Display
	#03 and #04	None	1	1
Cause	The two crank angle sensor measurements fail.			
Procedure	⇒ Do a check of the crank angle sensor unit and terminal box E96 for damage.			
	⇒ In the terminal box E96, make sure that the cables and connections are connected correctly and do not have damage.			
	⇒ If necessary, repair or replace damaged cables.			
	⇒ Use a multimeter to do a check of the power supply to the last and last but one FCM-20.			
	⇒ If there is a power supply, do a check of the SSI-Bus terminating resistors (120 ohm) on plugs X22 (terminals 51/52 and 53/54) and X23 (terminals 59/60 and 61/62) of FCM-20 #01. Make sure that the resistors are connected correctly and there is no damage.			
	⇒ If a failure shows only on one FCM-20, make sure that the cable connections on plugs X22 and X23 are serviceable.			
	⇒ Start a CAS trend in flexView.			
⇒ If necessary, replace a minimum of one two crank angle sensor immediately.				
Failure Text				
ME both CA / TDC high shift (ID 65)				
Indication	FCM-20 No.	LED	Failure ID	Display
	#05	BI1	65	65
Cause	The difference between the TDC pick-up (measured angle) and crank angle sensor#1 and sensor#2 is more than 4°CA. This failure will cause an engine shutdown. The crank angle sensor or toothed belt has moved.			
Procedure	⇒ In flexView, do a check for an incorrect TDC offset adjustment.			
	⇒ Adjust to get the correct distance of the TDC pick-up to the flywheel tooth (usually 4mm)			
	⇒ Make sure that the crankshaft has no deformation.			
	⇒ Do a check of the crank angle sensor drive and the belt for damage.			
	⇒ Make sure the the CAS#1 and CAS#2 are in the correct position (at TDC#1)			
	⇒ Start a CAS trend in flexView.			
⇒ If necessary, replace a minimum of one of the two crank angle sensors immediately				
Failure Text				
ME excessive engine speed (ID 69)				
Indication	FCM-20 No.	LED	Failure ID	Display
	#03 and #04	None	69	69
Cause	The engine has too much speed (more than 115% nominal speed).			
Procedure	⇒ Do a check of each alarm from the CA sensors			
	⇒ In heavy sea conditions, decrease the engine speed.			
	⇒ Do a check of related speed alarms in the safety system			

Failures and Defects of WECS Components

4.10 Malfunction of cylinder lubrication

LEDs on the ALM-20 show malfunctions and defects of the cylinder lubrication control system (see Fig. B). Data about irregular functions with the lubricating pump components, or in the lubricating and servo oil system are given in 0820-1, paragraph 2 Cylinder lubrication.

Failure text		ME cylinder lubrication malfunction cylinder #nn (ID 2.6)					
		ALM-20 No.	LED		Blink intervals	Failure ID	Display
Indication		#01 to #08	Pressure	Yellow	None	126	2.6
Cause	No pulse lubrication. The cylinder lubricating system has a malfunction, which activates a slow-down signal.						
Procedure	⇒ Do a check of the cables to the pressure transmitter, 4/2-way solenoid valve and WECS-9520 for correct connections and / or damage. ⇒ Find the cause of the malfunction of the ALM-20. ⇒ Do a check for low servo oil pressure, or no servo oil pressure. ⇒ If the servo oil pressure is correct, do a check of the lubrication pump components (see 0820-1, paragraph 2 Cylinder lubrication). ⇒ Make sure that the cables to the pressure transmitter, 4/2-way solenoid valve and WECS-9520 are correctly connected and have no damage. ⇒ If necessary, repair or replace damaged cables. ⇒ If necessary, replace he related ALM-20, or lubrication pump components (see 0820-1, paragraph 2 Cylinder lubrication).						
Failure text		Cylinder LUB Malfunction (ID 2.8)					
		ALM- No.	LED		Blink intervals	Failure ID	Display
Indication		#01 to #08	Pressure	Yellow	None	128	2.8
Cause	No pulse lubrication. The cylinder lubricating pumps have a malfunction, which activates a slow-down signal.						
Procedure	⇒ Do a check of the cables to the pressure transmitter, 4/2-way solenoid valve and WECS-9520 for correct connections and / or damage. ⇒ Find the cause of the malfunction of the ALM-20. ⇒ Do a check for low servo oil pressure, or no servo oil pressure. ⇒ If the servo oil pressure is correct, do a check of the lubrication pump components (see 0820-1 paragraph 2, Cylinder lubrication). ⇒ If necessary, repair or replace damaged cables. ⇒ Make sure that the cables to pressure transmitter, 4/2-way solenoid valve and WECS-9520 are correctly connected and have no damage. ⇒ If necessary, replace he related ALM-20, or lubrication pump components (see 0820-1, paragraph 2, Cylinder lubrication).						

Failures and Defects of WECS Components

Failure Text					ME cylinder lubrication malfunction cylinder #nn			
Indication	ALM-20 No.		LED		On / Off Code			
	#01 to #08		CAN1 and/or CAN2		Red		None	
Cause	LED indication on one module: a cable is broken on the plug X2 on the related ALM-20. LED indication on all modules: CAN Bus #1 / #2 malfunction.							
Procedure	⇒ LED indication on one module: Do a check of the cables on the plug X2 (terminals 25 and 26 CAN #1 and/or terminals 27 and 28 CAN #2 on the related ALM-20 for correct connections and / or damage.							
	⇒ LED indication on all modules: Do a check of the CAN module bus from the last and the last but one cylinder on the FCM-20 (plug X22, terminals 55 and 56) for correct connections and / or damage.							
	⇒ If necessary, repair or replace damaged cables.							
	⇒ If necessary, replace the ALM-20.							
Indication	ALM-20 No.		LED		On / Off Code			
	#01 to #08		VLV and Fail		Red		None	
Cause	The cables between the ALM-20 (plug X1, terminals 11 and 12) and the 4/2-way solenoid valve (ZV7131C to ZV7138C) have a short circuit.							
Procedure	⇒ Do a check of the related cables. If the cables are serviceable, the 4/2-way solenoid valve has a malfunction (coil R~18 ohm).							
	⇒ Make sure that the related cable between ALM-20 (plug X1, terminals 11 and 12) and the 4/2-way solenoid valve is correctly connected and has no damage.							
	⇒ If necessary, repair or replace damaged cables.							
	⇒ If necessary, replace the related 4/2-way solenoid valve (see 0820-1, paragraph 2 Cylinder lubrication).							
Indication	ALM-20 No.		LED		On / Off Code			
	#01 to #08		VLV and Fail		Red		None / 1x	
Cause	A cable is broken between the ALM-20 (plug X1, terminals 11 and 12) and the 4/2-way solenoid valve (ZV7131C to ZV7138C).							
Procedure	⇒ Do a check of the related cables. If the cables are serviceable, the 4/2-way solenoid valve has a malfunction (coil R~18 ohm).							
	⇒ Make sure that the related cable between the ALM-20 (plug X1, terminals 11 and 12) and the 4/2-way solenoid valve is correctly connected and has no damage.							
	⇒ If necessary, repair or replace damaged cables.							
	⇒ If necessary, replace the related 4/2-way solenoid valve (see 0820-1, paragraph 2 Cylinder lubrication)							

Failures and Defects of WECS Components

Failure Text					ME cylinder lubrication malfunction cylinder #nn				
Indication	ALM-20 No.		LED		On / Off Code				
	#01 to #09		Fail		Red		None		
Cause	A short circuit of the cables from ALM-20 (plug X1, terminals 13 and 14) to the pressure transmitter (PT3131 to PT3139C).								
Procedure	⇒ Do a check of the cables on the related ALM-20. If the cables are serviceable, the pressure transmitter has a malfunction.								
	⇒ Make sure that the related cable between the ALM-20 (plug X1, terminals 13 and 14) and pressure transmitter is connected correctly and has no damage.								
	⇒ If necessary, repair or replace damaged cables.								
	⇒ If necessary, replace the related pressure transmitter (PT3131C to PT3137C) (see 0820-1 paragraph 2 Cylinder lubrication).								
Indication	ALM-20 No.		LED		On / Off Code				
	#01 to #09		Fail		Red		Two times each interval		
Cause	A cable is broken between an ALM-20 (plug X1, terminals 13 and 14) and the pressure transmitter (PT3131C to PT3139C).								
Procedure	⇒ Do a check of the cables on the related ALM-20. If the cables are serviceable, the pressure transmitter has a malfunction								
	⇒ Make sure that the related cable connections between ALM-20 (plug X1, terminals 13 and 14) and pressure transmitter are connected correctly and have no damage.								
	⇒ If necessary, repair or replace damaged cables.								
	⇒ If necessary, replace the related pressure transmitter (PT3131C to PT3139C) if necessary (see 0820-1 Cylinder lubrication)								
Indication	ALM-20 No.		LED		On / Off Code				
	#01 to #09		Power		Off		None		
Cause	No power supply to an ALM-20								
Procedure	⇒ In E85, do a check of the power supply units U500 / U501 and their circuit breakers F500 / F501								
	⇒ If a green LED DC OK shows, do a check of the cables on the related ALM-20 (plug X2, terminals 21 and 22 or 23 and 24)								
	⇒ If a green LED DC OK flashes, do a check of the cables on the related ALM-20 and/or the related ALM-20 (do a check for a short circuit)								
	⇒ Make sure that the cable between E85 and the related ALM-20 (plug X2, terminals 21 and 22 or 23 and 24) is correctly connected and has no damage.								
	⇒ If necessary, repair or replace damaged cables.								
⇒ Replace the related ALM-20 (if there is a short circuit)									

Intentionally blank

Bedplate and Tie Rod

Group 1

Main Bearing	1132-1/A1
Thrust Bearing	1203-1/A1
Tie Rod	1903-1/A1

Intentionally blank

Main Bearing

1. General

The main bearing has a lower bearing shell 2 and an upper bearing shell 3. The running surfaces of the bearing shells are lined with white metal.

The lower bearing shell 2 is installed in the bearing girder 6 of the bedplate and the upper bearing shell 3 in the bearing cover 1. The screws 9 engage and hold the top bearing shell and bottom bearing shell in position.

The spring dowel pin 8 helps to get the bearing cover 1 in position.

The elastic studs 4 have a non-hardening locking compound applied to the threads. Hydraulic tension is applied to the the elastic studs 4 during the install procedure. The round nuts 5 keep the bearing cover 1 against the bearing girder 6.

2. Lubrication

Oil flows from the bedplate side through the oil inlet 'OI' to the main bearings. The oil flows through the grooves 'OG' and bores 'OB' to the running surface of the main bearing.

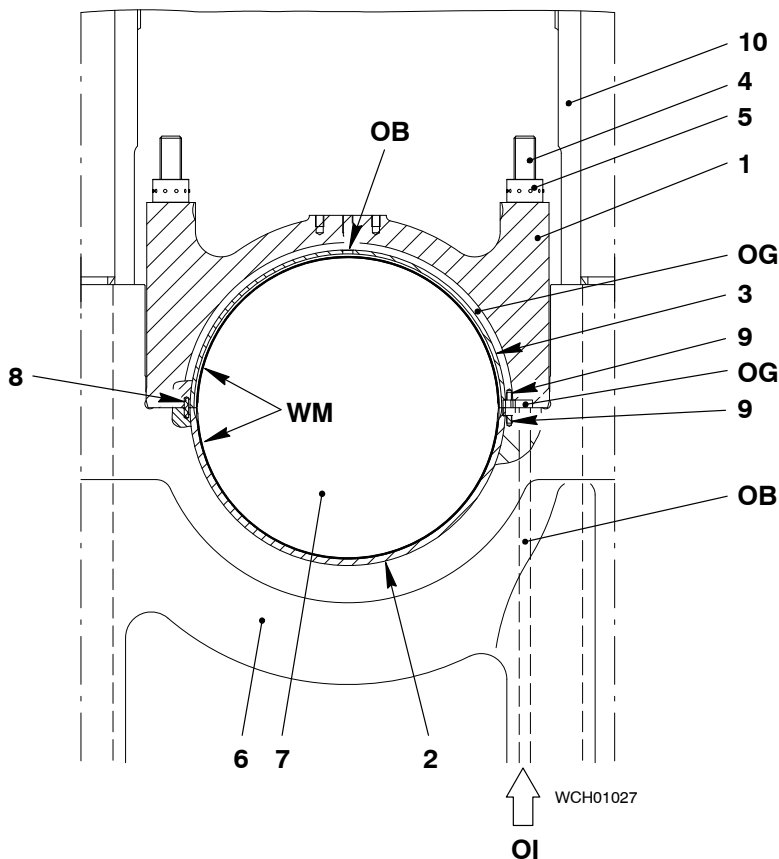

- Key:**
- 1 Bearing cover
 - 2 Lower bearing shell
 - 3 Upper bearing shell
 - 4 Elastic stud
 - 5 Round nut
 - 6 Bearing girder
 - 7 Crankshaft
 - 8 Spring dowel pin
 - 9 Screw
 - 10 Column
- OB Bore
 OI Oil inlet
 OG Groove
 WM White metal

Intentionally blank

Thrust Bearing

1. General

The thrust bearing is installed at the driving end of the engine. The thrust bearing flange 15 transmits the force from the propeller through the thrust pads 6, 12 into the bedplate 5 (see Fig. 'A' and Fig. 'B').

The arbor supports 4 prevent axial movement of the thrust pads 6, 12.

The thrust pads absorb the axial force from the crankshaft/propeller.

Engines that have a fixed pitch propeller (FPP):

- For clockwise and counterclockwise rotation, seven thrust pads are installed on each side of the thrust bearing flange. The thrust pads are related and adapted to the clockwise or counterclockwise rotation.

Engines that have a controllable pitch propeller (CPP):

- Thrust pads at the driving end: Each variant, i.e. three thrust pads for clockwise rotation and four pieces for counterclockwise rotation are installed. If there is a malfunction of the CPP, the engine must continue to be manoeuvrable and reversed to ASTERN direction.
- Thrust pads at the free end: There are seven thrust pads installed, related and adapted to the clockwise or counterclockwise rotation.

For the location of the different thrust pad versions, refer to the Maintenance Manual 1224-1.

The gear wheel (on crankshaft) 13 is installed on the thrust bearing flange 15. The gear wheel moves the intermediate wheel (supply unit) 8.

2. Lubrication

During operation, bearing oil flows through the oil pipe 2 to the two nozzles 3. The oil flows out of the two nozzles as a spray, which becomes an oil layer between the thrust bearing flange 15 and the thrust pads 6, 12.

Thrust Bearing

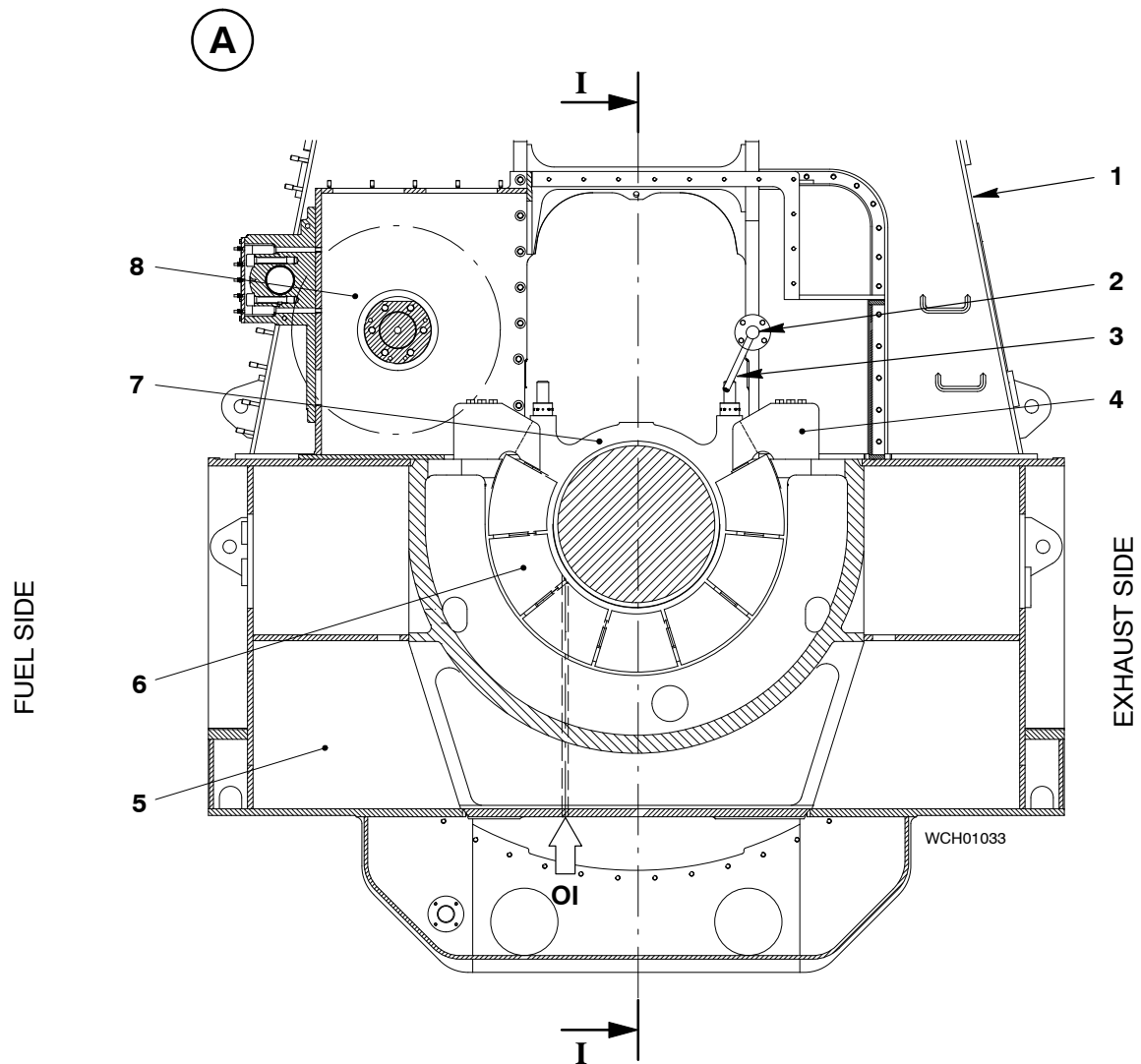
**Key to Illustrations: 'A' Cross section (5 to 7 cylinders)**

- | | |
|-----------------|------------------------------------|
| 1 Column | 6 Thrust pad (free end) |
| 2 Oil pipe | 7 Bearing cover |
| 3 Nozzle | 8 Intermediate wheel (supply unit) |
| 4 Arbor support | OI Bearing oil inlet |
| 5 Bedplate | |

Thrust Bearing

B

I-I

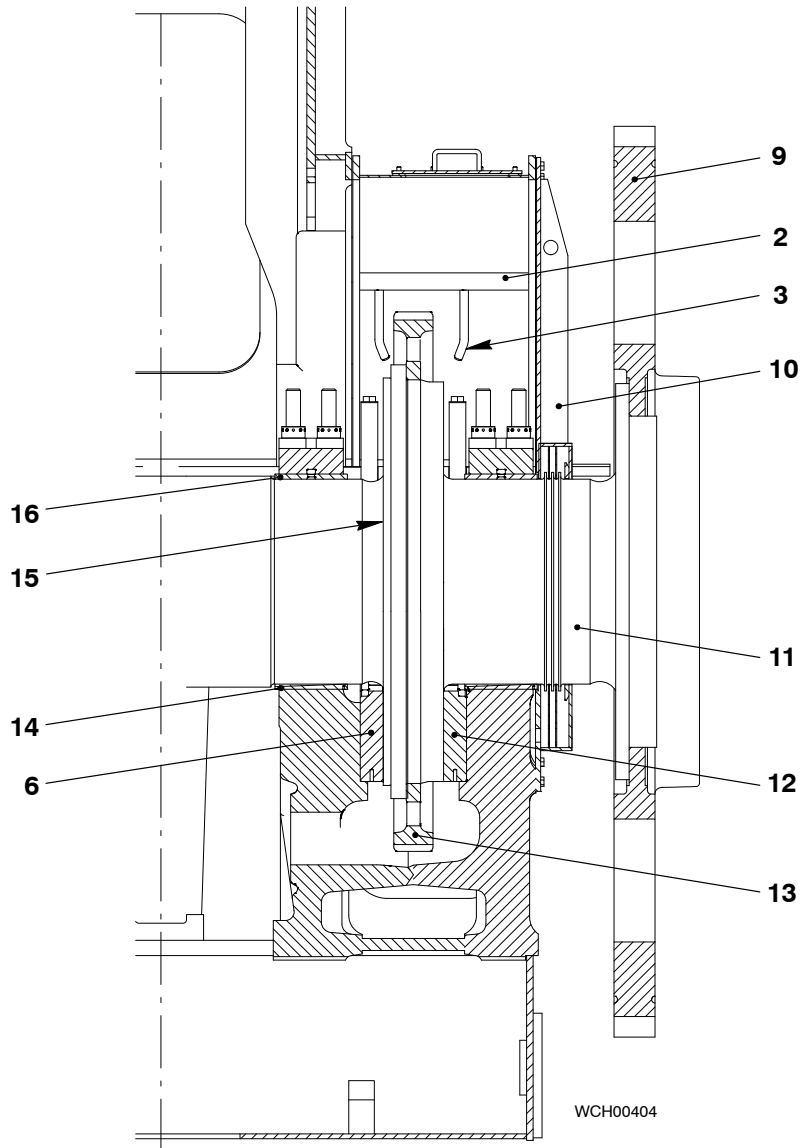

Key to Illustrations: 'B' Longitudinal section (5 to 7 cylinders)

- | | |
|--------------------------|---------------------------------------|
| 2 Oil pipe | 12 Thrust pads (driving end) |
| 3 Nozzle | 13 Gear wheel (on crankshaft) |
| 6 Thrust pads (free end) | 14 Oil pipe |
| 9 Flywheel | 15 Thrust bearing flange (crankshaft) |
| 10 2-part oil baffle | 16 Top main bearing shell |
| 11 Crankshaft | |

Intentionally blank

Tie Rod

1. General

The tie rods 1 keep the cylinder block 2, column 3 and bedplate 4 together at four locations around the cylinders.

A

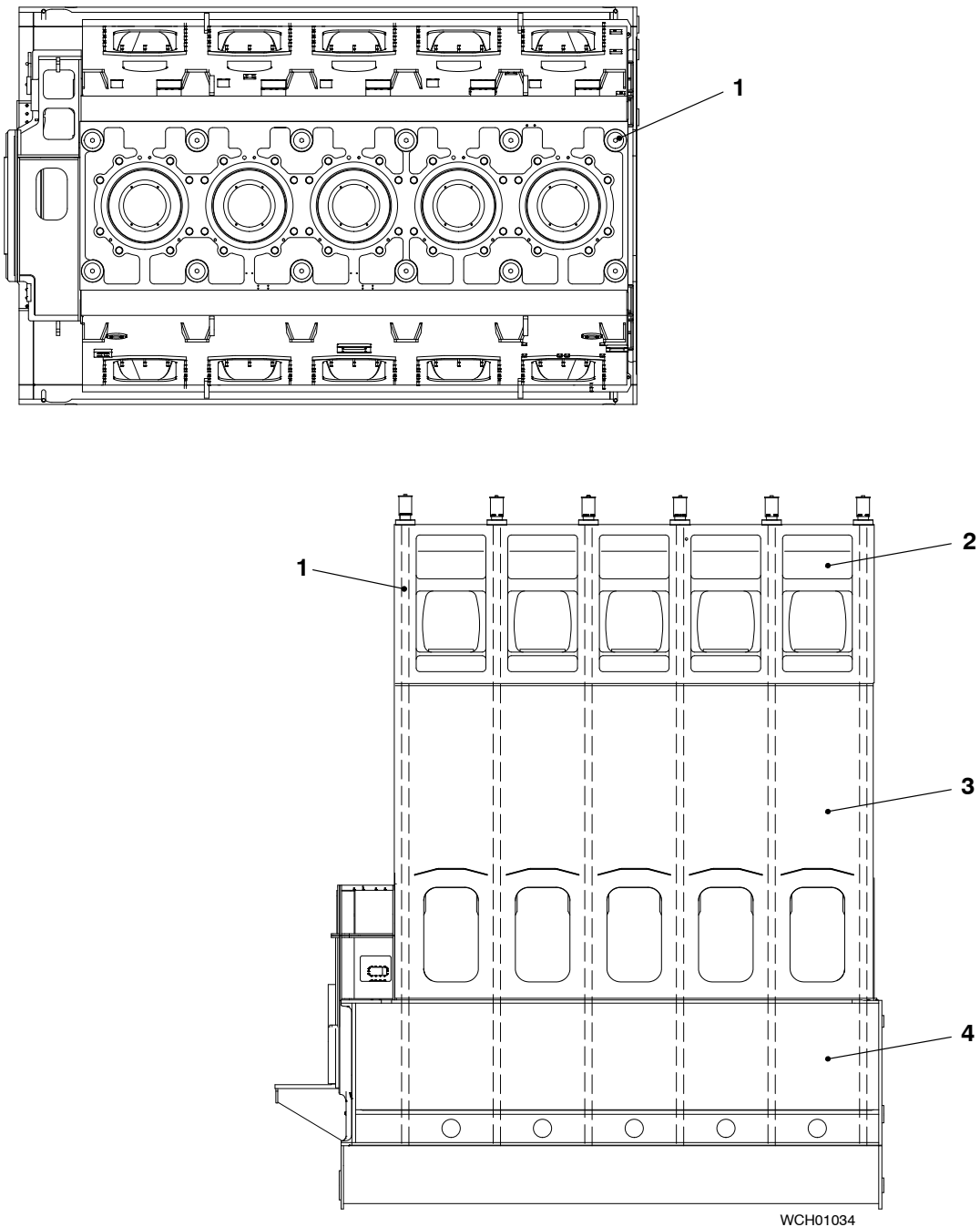

WCH01034

Key to Illustration: 'A' Tie rods and tie rod locations (5-cylinder engine)

- 1 Tie rod
- 2 Cylinder block
- 3 Column
- 4 Bedplate

Tie Rod

A two-part bush 3 is welded on the tie rod 4 as shown in view I. At the bottom of the cylinder block, two clamp screws 1 tightly attach the two-part bush and prevent vibration of the tie rods. The space around the bottom part of the tie rod up to the middle of the column is filled with oil, which also prevents vibration. The oil enters through a bore from the crosshead guide plate.

The bottom of the intermediate ring 7 has a drain groove 'DG' through which some of the oil can drain. Possible condensation can also drain through 'DG' (if the engine has stopped).

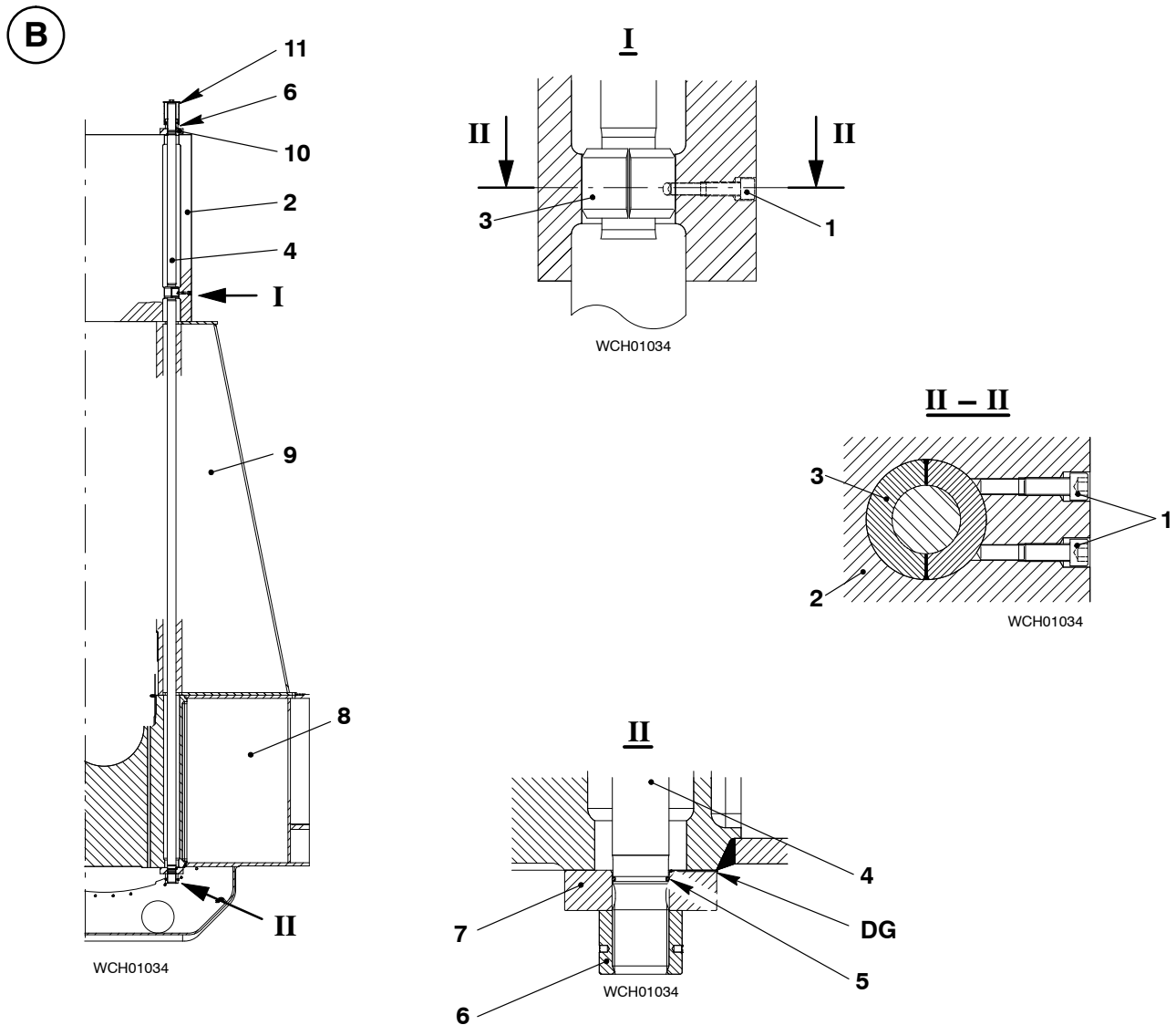

Key to Illustration: 'B' Tie rod assembly

- | | | | |
|---|----------------|----|--------------------------------------------|
| 1 | Clamp screw | 7 | Intermediate ring (bottom) |
| 2 | Cylinder block | 8 | Bedplate |
| 3 | Two-part bush | 9 | Column |
| 4 | Tie rod | 10 | Intermediate ring (top) |
| 5 | O-ring | 11 | Protection cover |
| 6 | Round nut | DG | Drain groove (in bottom intermediate ring) |

Cylinder Liner and Cylinder Cover

Group 2

Cylinder Liner	2124-1/A3
Lubricating Quills on Cylinder Liner	2138-1/A2
Piston Rod Gland Box	2303-1/A1
Injection Valve	2722-1/A1
Starting Air Valve	2728-1/A1
Exhaust Valve	2751-1/A3

Intentionally blank

Cylinder Liner

1. General

The screws and holder 8 attach the cylinder liner 9 to the cylinder block 7. The nuts of the elastic studs connect the cylinder cover 14 and the cylinder liner to the cylinder block. The area between the cylinder cover and the cylinder liner is sealed with a gasket 3. The surface 'MS' is sealed with a non-hardening sealing compound (see Fig. A).

The upper water guide jacket 1 is attached to the cylinder cover 14 with cap screws. The lower water guide jacket 12 is attached to the cylinder liner 9 with bolts.

An insulation bandage 11 is attached to the cylinder liner to keep the wall temperature of the mid-stroke area in the best range for operation.

An antipolishing ring is installed in the top part of the cylinder liner. The antipolishing ring 4 removes coke contamination at the piston crown during operation.

2. Cooling

The cooling water flows through the cooling water inlet 'CI' into the water space 'WS', around the cylinder liner 9 and into the lower water guide jacket 12. The cooling water flows into the annular space 'AS' through the connection pieces 5 and transition tubes 2. Then the water cools the cylinder cover 14, exhaust valve seat 15 and valve cage 16.



Remark: Automatic cooling water temperature control:

To prevent unwanted tensions in the top part of the cylinder liner 9 keep the temperature of the cooling water in the permitted range. The maximum permitted temperature ranges are:

- $\pm 2^{\circ}\text{C}$ at constant load
- $\pm 4^{\circ}\text{C}$ during load changes (short time period)

O-rings 10, 13 seal the water space 'WS' and the annular space 'AS'. If water leaks, replace the O-rings.

3. Lubrication

Cylinder lubricating oil flows to the running surface of the cylinder liner 9 through six lubricating quills 6. Lubricating grooves 'LG' are milled around the circumference of the cylinder liner and make sure that the lubricating oil is equally supplied (see Lubricating Quill [2138-1](#)).

For data about the pulse lubrication, see [7218-1](#).

Cylinder Liner

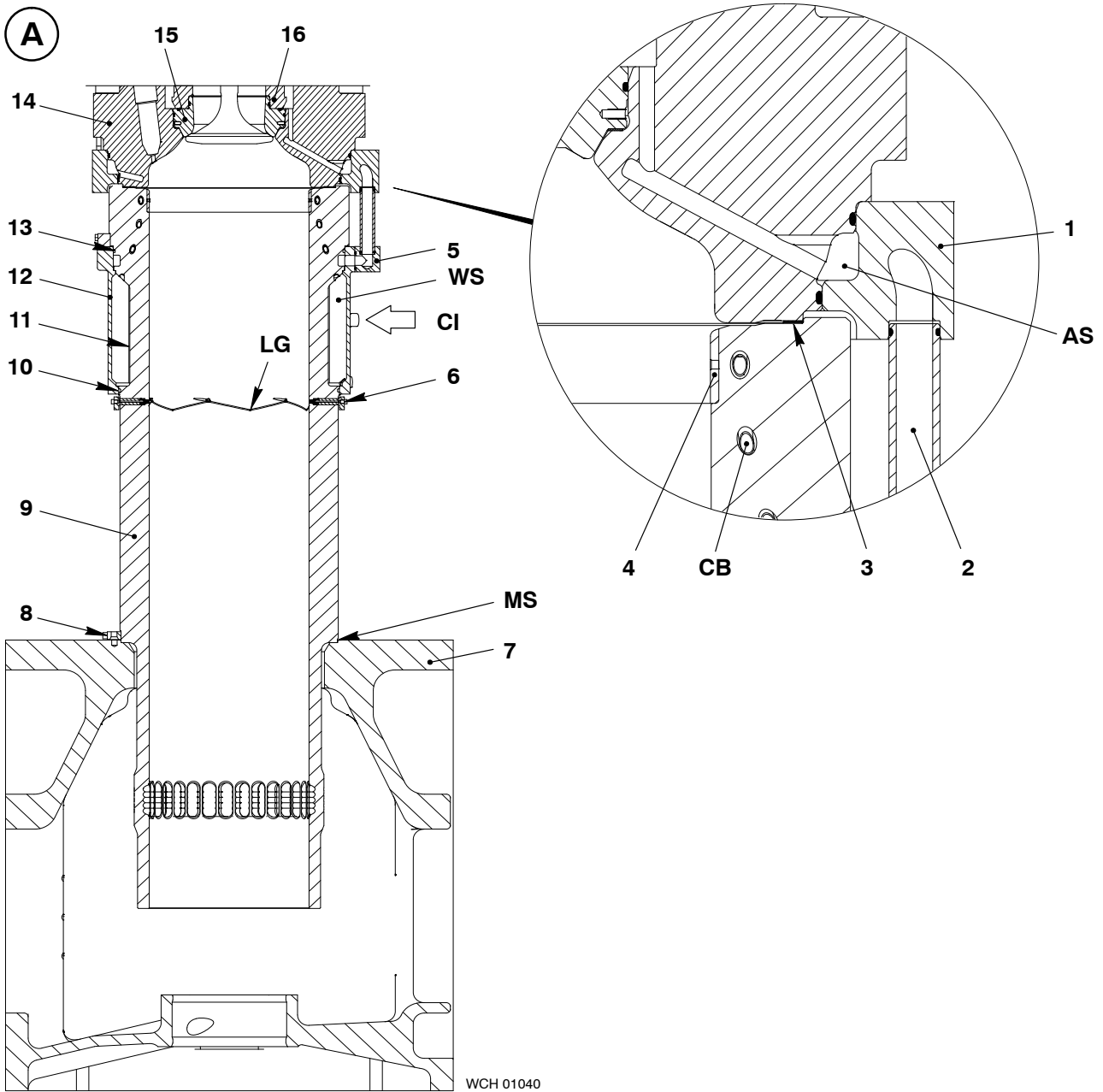

Key to Illustrations: 'A' Cylinder Liner

- | | |
|-----------------------------|------------------------|
| 1 Upper water guide jacket | 13 O-ring |
| 2 Transition tube | 14 Cylinder cover |
| 3 Gasket | 15 Valve seat |
| 4 Antipolishing ring | 16 Valve cage |
| 5 Connection piece | |
| 6 Lubricating quill | AS Annular space |
| 7 Cylinder block | CB Cooling bores |
| 8 Holder | WS Water space |
| 9 Cylinder liner | CI Cooling water inlet |
| 10 O-ring | MS Metallic seal |
| 11 Insulation bandage | LG Lubricating grooves |
| 12 Lower water guide jacket | |

Lubricating Quills on Cylinder Liner

1. General

Six lubricating quills 1 are installed around the circumference of the cylinder liner 2. The lubricating pump 3 supplies lubricating oil through pipes to each lubricating quill (see Fig. 'A').

The nozzle tip 7 with non-return valve 6 and holder 9 are attached as a unit to the cylinder liner 2 with cap screws (see Fig. 'B').

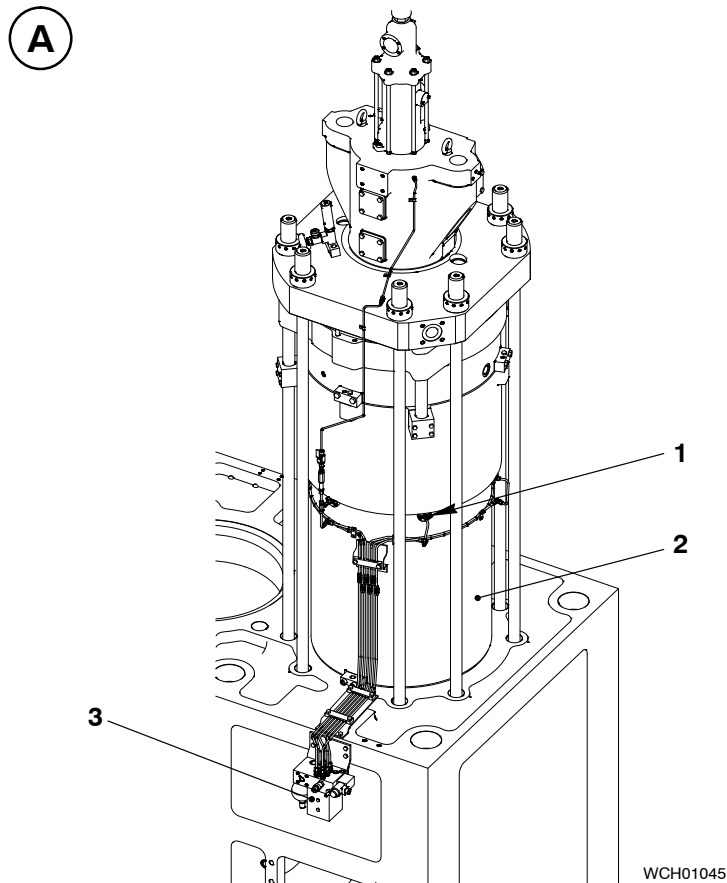

Key to Illustration: 'A' Location of lubricating quills

- 1 Lubricating quill
- 2 Cylinder liner
- 3 Lubricating pump

2. Function

The lubricating pump 3 supplies a set feed rate of lubricating oil at high pressure through the connection 'OI' into the lubricating quills 1. The non-return valve 6 opens and the lubricating oil flows through the lubricating point 'LP' into the lubricating grooves. The lubricating oil flows equally on to the cylinder liner wall. (see also Cylinder Liner [2124-1](#) and Cylinder Lubrication [7218-1](#)).

After a lubrication pulse, the oil pressure decreases and the force of the pressure spring closes the non-return valve.

Lubricating Quills on Cylinder Liner

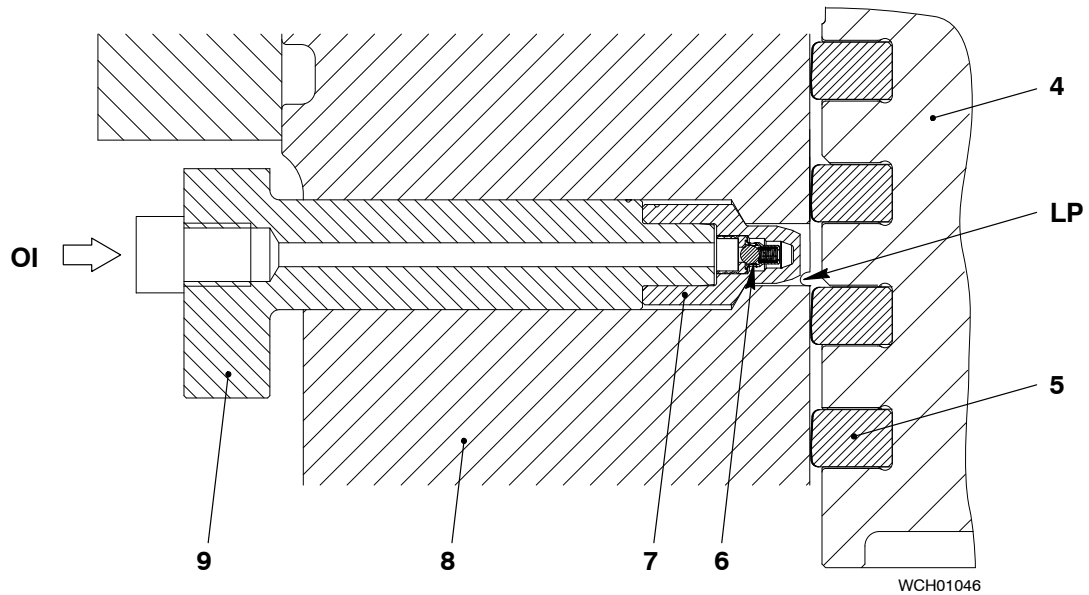
B**Key to Illustration: 'B' Lubricating quill**

- | | | | |
|---|------------------|----|-------------------------------------|
| 4 | Piston | LP | Lubricating point in cylinder liner |
| 5 | Piston ring | OI | Oil inlet |
| 6 | Non-return valve | | |
| 7 | Nozzle tip | | |
| 8 | Cylinder liner | | |
| 9 | Holder | | |

Piston Rod Gland Box

1. General

The piston rod gland box 1 keeps the dirty oil in the scavenge space 'SS' and prevents contamination of the bearing oil (see Fig. 'A'). Also, the piston rod gland box seals the scavenge air from the crankcase 2.

The screws and ring 7 attach the casing 5 to the cylinder block 4 (see Fig. 'B'). The extension springs 6 keep the scraper rings 13 and joint rings 11, 12 tightly on the piston rod. The scraper rings 10 are attached to the ring supports 9. The extension springs 8 keep the scraper rings 10.

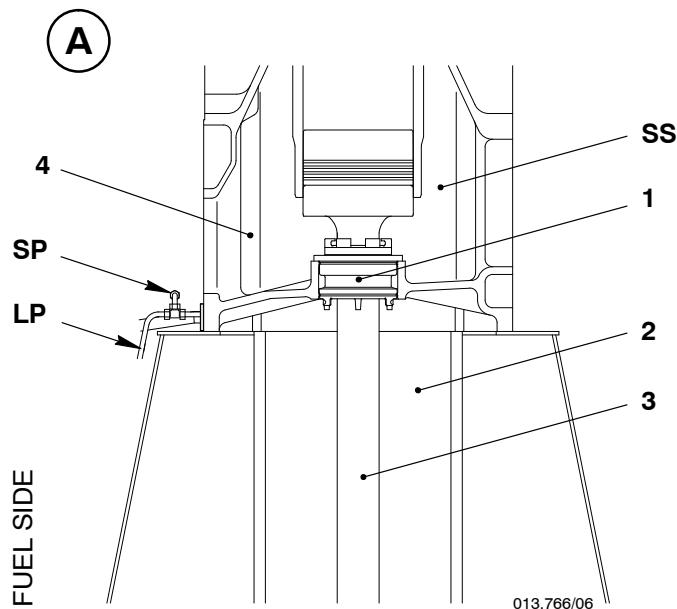

Key to Illustration: 'A' Configuration of piston rod gland box

1	Piston rod gland box	SS	Scavenge space
2	Crankcase	LP	Leakage oil pipe
3	Piston rod	SP	Sample port
4	Cylinder block		

2. Function

During operation, three scraper rings 13 remove dirty oil from the piston rod 3 (see Fig. 'A' and Fig. 'B'). The dirty oil flows through the oil bores 'OB' and collects in the bottom of the scavenge space 'SS'. The dirty oil goes out through the oil drain on fuel side.



Attention! Oil at the bottom of the scavenge space 'SS' increases the risk of fire. Examine the drain hole and the pipe for blockage (see 0450-1). If necessary, clean the drain hole and the pipe (see 0240-1).

Piston Rod Gland Box

The joint rings 11, 12 keep the scavenge air from the crankcase 2. Because of the gap losses of the joint rings, the low air pressure is released through the crankcase venting pipe to the plant.

The oil that flows through the relief passage 'RP' collects in the neutral space 'NS'. Then, the oil flows through the leakage oil drain 'LD' and the leakage oil pipe 'LP' (see Fig. 'A' and Fig. 'B').



Remark: Damaged joint rings increase the quantity of oil in the drain. Get an oil sample from the sample port 'SP' (see Fig. 'A'). Measure the quantity or send the oil sample to the laboratory for analysis of the contamination. If necessary, replace the joint rings.

The scraper rings 10 remove the bearing oil from the piston rod 3. The bearing oil flows through the bearing oil drain 'BD' back to the crankcase 2 (see Fig. 'B').

Piston Rod Gland Box

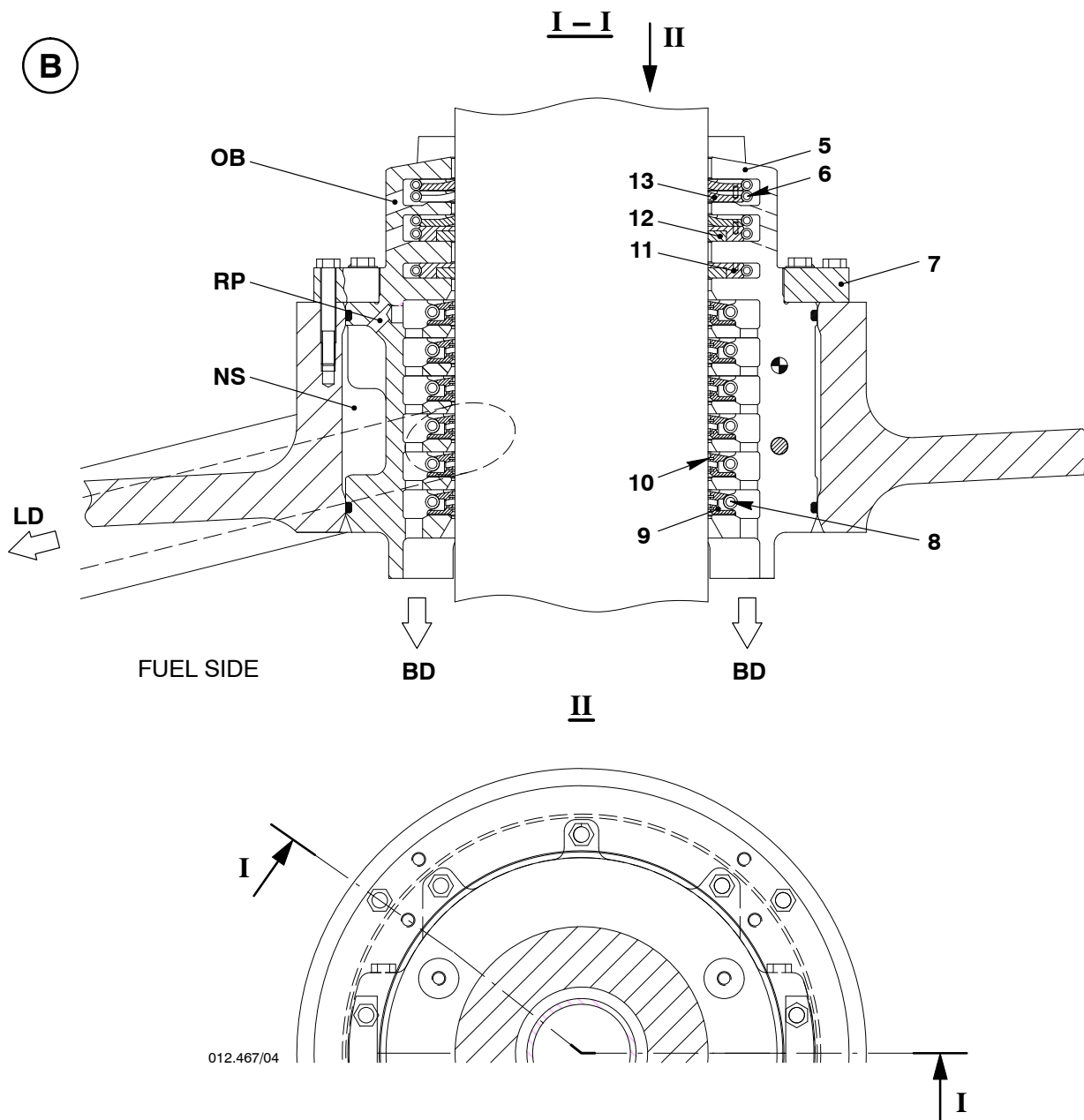

Key to Illustration: 'B' Piston rod gland box

- | | |
|--------------------|----------------------|
| 5 Casing | BD Bearing oil drain |
| 6 Extension spring | LD Leakage oil drain |
| 7 Ring (2-part) | NS Neutral space |
| 8 Extension spring | RP Relief passage |
| 9 Ring support | OB Oil bore |
| 10 Scraper ring | |
| 11 Joint ring | |
| 12 Joint ring | |
| 13 Scraper ring | |

Intentionally blank

Injection Valve

1. General

Three injection valves 2 are attached to each cylinder cover 1 (see Fig. 'A').

Because of the clearance between the needle 1 and the nozzle body 3, some fuel can go out of the injection valve (see Fig. 'B'). This fuel goes through connection 'LD' and drains through the leakage fuel pipe 7 into the collecting piece 6 (see Fig. 'A' and Fuel Oil System 8019-1).

Fuel oil which possibly leaks between the nozzle body 3 and the nozzle holder 4 rises and appears at the top edge of the cylinder cover at 'LO'.



Remark: If fuel does appear at 'LO', overhaul the applicable parts. If exhaust gas goes out of the injection valve at the leakage fuel outlet 'LO', the sealing face 'SF' is damaged. Do an overhaul of the sealing face (see 2708-3 in the Maintenance Manual).

To do tests, disassembly, assembly and setting of injection valves, see 2722-1 in the Maintenance Manual.



Attention! Fuel is at high pressure in the fuel leakage pipes 7. Before you remove the fuel leakage pipes, make sure that the pressure is released.

2. Function

Fuel flows at high pressure from the injection control unit 4 to the three injection valves 2 (see Fig. 'A'). The necessary quantity of fuel goes through the connection 'FF' and the bore 'FB' into the nozzle body 3 (see Fig. 'A'). The pressure increases and pushes the needle 1 up. The fuel goes through the nozzle tip 2 into the combustion chamber, where ignition occurs.

After injection, the pressure decreases and the force of the compression spring 5 pushes the needle down. The injection valve closes.

Injection Valve

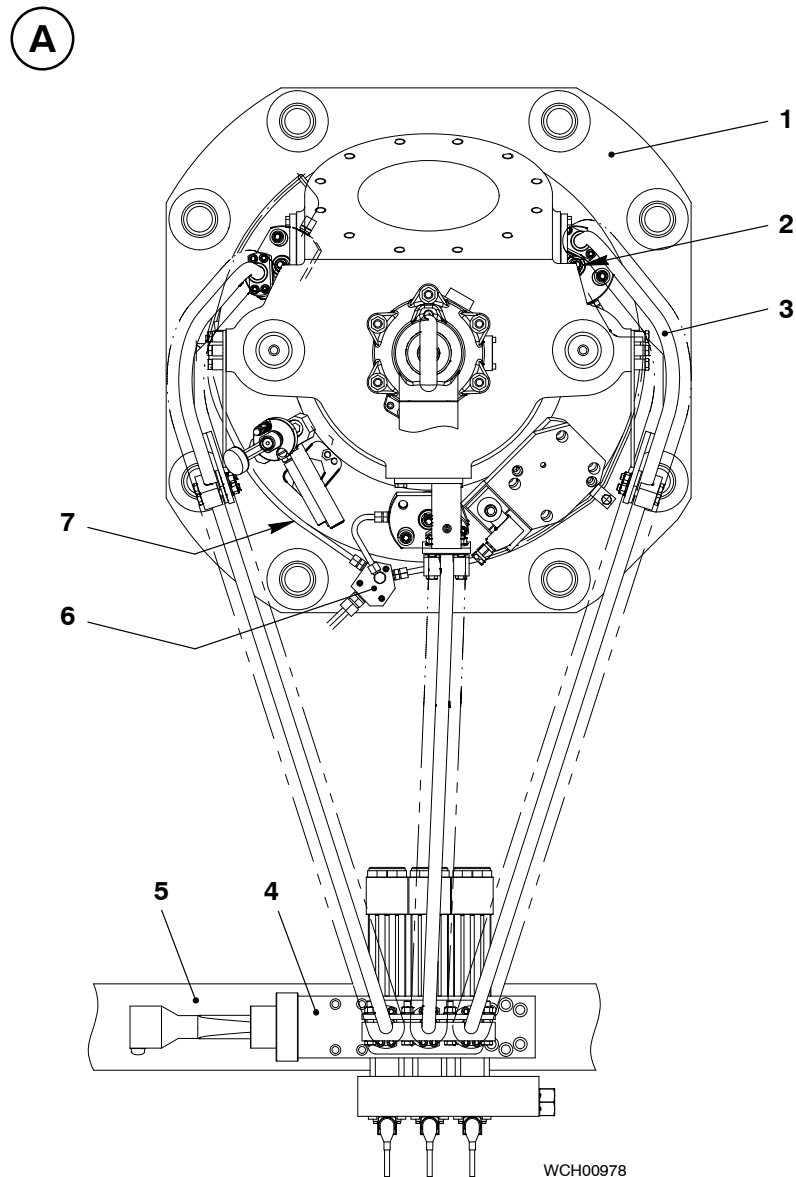
**Key to Illustration: 'A' Location of parts**

- | | |
|--------------------------|---------------------|
| 1 Cylinder cover | 5 Fuel rail |
| 2 Injection valve | 6 Collecting piece |
| 3 Injection pipe | 7 Leakage fuel pipe |
| 4 Injection control unit | |

Injection Valve

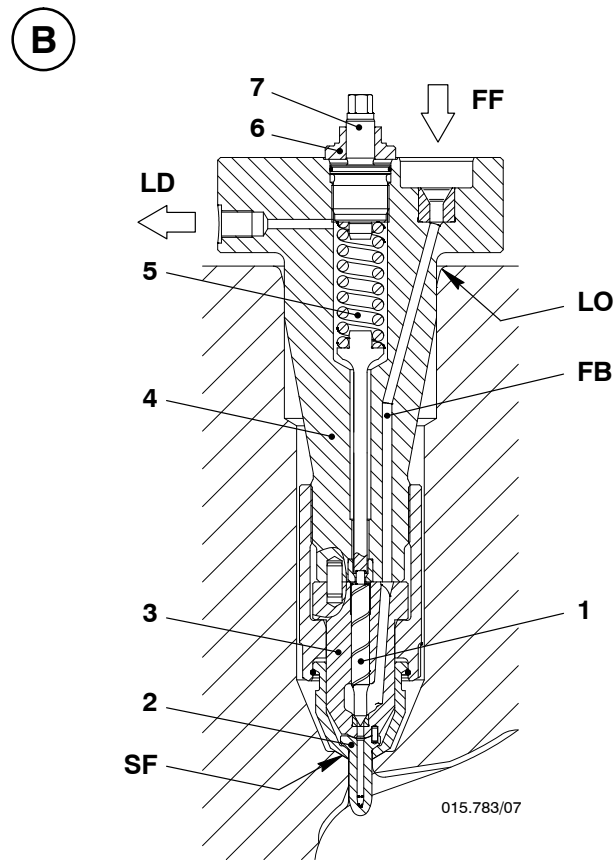

Key to Illustration: 'B' Injection valve

- | | |
|----------------------|------------------------|
| 1 Needle | FF Fuel feed |
| 2 Nozzle tip | LO Leakage fuel outlet |
| 3 Nozzle body | FB Fuel bore |
| 4 Nozzle holder | SF Sealing face |
| 5 Compression spring | LD Leakage fuel drain |
| 6 Collar nut | |
| 7 Spring tensioner | |

Intentionally blank

Starting Air Valve

1. General

A starting air valve is installed in each cylinder cover 8 (see Fig. A). The starting air valves start the engine or decrease the engine speed for reversing.

The Wärtsilä Engine Control System (WECS-9520) monitors and controls the starting air valve operation (see 4002-1, paragraph 4.4). FCM-20 modules open the starting air valves electronically at the correct crank angle to release starting air into the combustion chamber.

The parameter settings of the starting air valves are adjustable. The remote control of the WECS-9520 gives access to the parameter settings (see 4618-1, paragraph 2.2).

For data about starting air manifold venting, read the instructions in 0320-1, paragraph 1.2.

For more data, see the schematic diagram in 4003-2.

2. Function

Initial conditions:

The space 'SA' is pressurized with starting air. The air flows through the bores 'CB' to pressurize the space 'S₃' (see Fig. A). The compression spring 6 and the starting air push the piston 4 up and keep the starting air valve closed.

Connection 'CA' is pressurized with control air from the starting air pipe. The 5/2-way solenoid valve 1 is deactivated. Thus, the control air from connection 'CA' cannot go into the space 'S₁'.

Space 'S₂' is pressurized with control air from connection 'CA'. The air flows into the space 'S₂' through the 5/2-way solenoid valve and the connecting pipe.

Engine start:

The FCM-20 module activates the 5/2-way solenoid valve 1. The control air from connection 'CA' goes into the space 'S₁' and the pressure in space 'S₂' is released.

The pressure in space 'S₁' moves the piston 4 and valve spindle 7 down and the starting air flows into the combustion chamber. Thus, the piston moves down the cylinder liner and starts to turn the engine.

When combustion starts, the higher pressure (firing pressure) in the combustion chamber keeps the starting air valve closed.

Slow down the engine speed to reverse:

If the combustion and thus the propulsion stops, the movement of the ship continues. The flow of the water turns the propeller and 'drags' the engine in the initial direction of rotation. To start the engine in the opposite direction, it is necessary to slow down the engine speed below the set limit. Related to the engine speed and the propeller configuration, this can take some time, even minutes.

At the specified engine speed the WECS-9520 opens the starting air valve at approximately 100° before TDC. The starting air flows into the combustion chamber. The piston moves up, compresses the air and the engine speed decreases and stops.

The engine is then started in the opposite direction of rotation. For more data about reversing, see 0260-1, paragraph 2.2.

Starting Air Valve

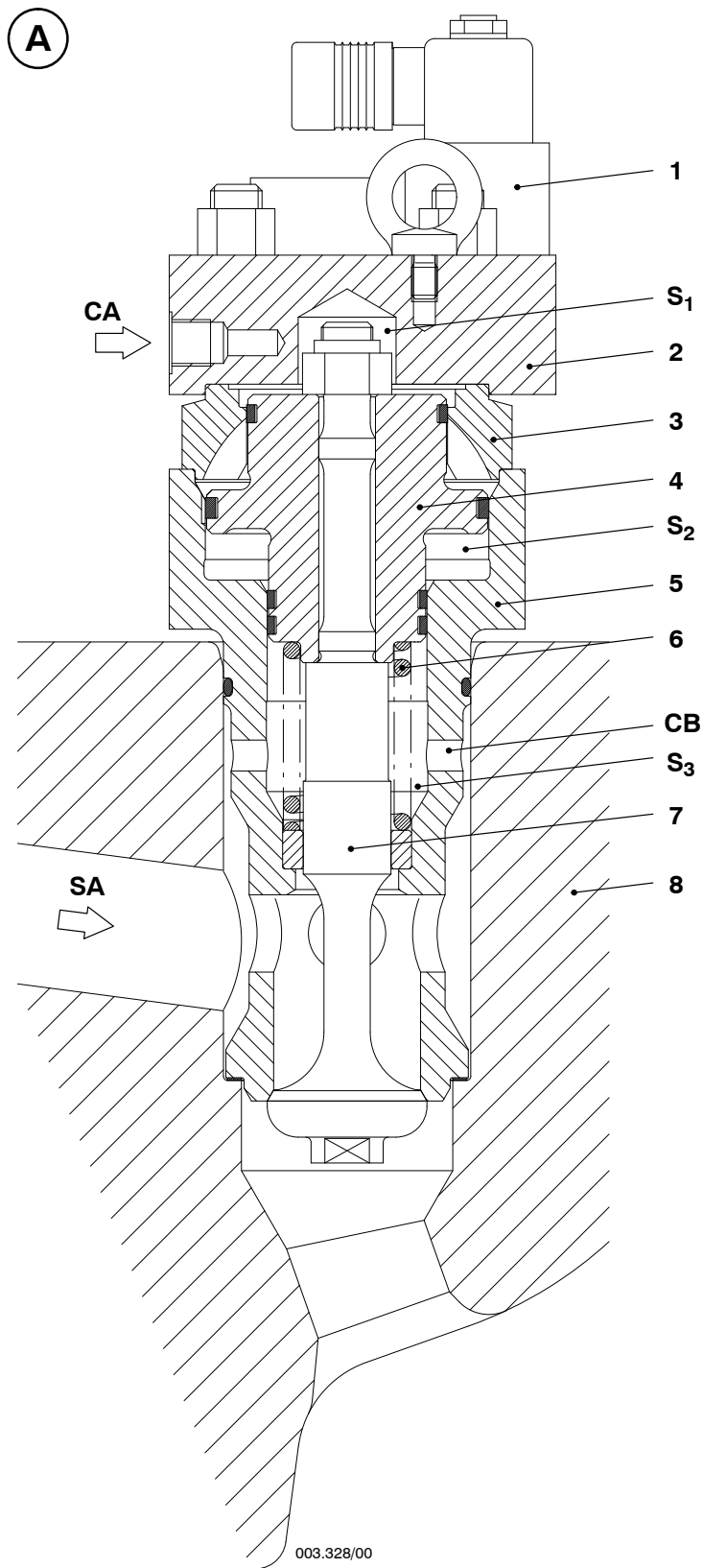

Key to Illustration: 'A'

- 1 5/2-way solenoid valve
- 2 Cover
- 3 Ring
- 4 Piston
- 5 Housing
- 6 Compression spring
- 7 Valve spindle
- 8 Cylinder cover

- SA Starting air
- CB Connecting bore
- S₁-S₃ Air spaces
- CA Control air

Exhaust Valve

1. General

The exhaust valve is attached to the center of cylinder cover 10 and has the parts that follow:

- Upper housing 2
- Housing 6
- Valve cage 9
- Valve spindle 13
- Valve seat 11
- Air spring 'AS'.

The valve stroke sensor 17 monitors and transmits the open and closed positions of the exhaust valve to the WECS-9520 engine control system (see Fig. 'B').

If there is a large pressure difference between when the exhaust valve opens and the pressure in the air spring 'AS', damage can occur to the exhaust valve. Thus, for safety, cup springs 7 are installed to absorb vibration and shock.

The thrust piece 15 prevents damage to the inside piston 5 and the top of the valve spindle 13 when the exhaust valve operates.



Remark: Before the lubricating oil pump and servo oil service pump are set to on, the air spring must have pressure and the exhaust valves must be closed. The engine cannot be started if the exhaust valves are not fully closed.

2. Function

Open:

When the piston in the exhaust valve control unit operates, hydraulic oil 'HO' flows through the connection 14 into the upper housing 2. The outside piston 4 and the inside piston 5 move down. The air spring piston 18, which is attached to the valve spindle 13, moves down against the pressure in the air spring 'AS' and the exhaust valve opens. The force of the exhaust gas on the rotation wing 17 turns the valve spindle.

Close:

When the hydraulic oil pressure from the exhaust valve control unit decreases (i.e. when the control rod in the exhaust valve control unit opens the related relief bores) the pressure in the air spring 'AS' pushes the air spring piston 18 up. The valve spindle 13 then pushes the inside piston 5 and the outside piston 4 up and the exhaust valve closes. The hydraulic oil in the upper housing 2 flows back to the exhaust valve control unit.

2.1 Hydraulic system (see Fig. 'B' and Fig. 'C')

Hydraulic oil and air in the system flow continuously from the upper housing 2 and the outside and inside pistons 4, 5 into the leakage oil collection space 'LS'. This leakage oil / air then drains through the leakage oil drain 'LD'. The hydraulic oil that flows through the valve control unit continuously makes up the oil loss to the hydraulic system.

2.2 Air supply to air spring (see Fig. 'C')

Compressed air enters the inlet connection 'AI' and flows through the non-return valve 19, then through the inlet bore 'IB' and into the air spring 'AS'. When the exhaust valve opens, the air spring piston 18 moves down and compresses the air in the air spring. Some of the compressed air flows back through the inlet bore 'IB'. After the exhaust valve closes, compressed air flows into the air spring again.

Exhaust Valve

3. Lubrication

Leak oil from the outside and inside pistons 4, 5 lubricates the air spring piston 18 (see Fig. C). Oil in the leakage oil collection space 'LS' drains to the leakage oil drain 'LD'. While the exhaust valve closes, oil flows through the air spring piston 18 and goes into the air spring 'AS'. The air from the air inlet 'AI' changes the oil that collects at the bottom of the air spring (inlet bore 'IB') to an oil mist. This oil mist lubricates the top part of the valve spindle 13. When the exhaust valve opens, unwanted oil flows out of the air spring 'AS', through the air spring pipe to an accumulator. The oil in the accumulator automatically drains through the leakage oil pipe at the driving end and into the crankcase.

Oil from the oil bath 'OB' lubricates the valve spindle 13 (see Fig. 'C').



Remark: The oil supply 'OS' from the cylinder lubrication flows to the guide bush 8. This gives more lubrication to the valve spindle 13 during the initial hours of engine operation, or after an exhaust valve overhaul. For more data about the initial hours of engine operation / after an exhaust valve overhaul, see [7218-1](#) 'Additional lubrication of exhaust valve spindle'.

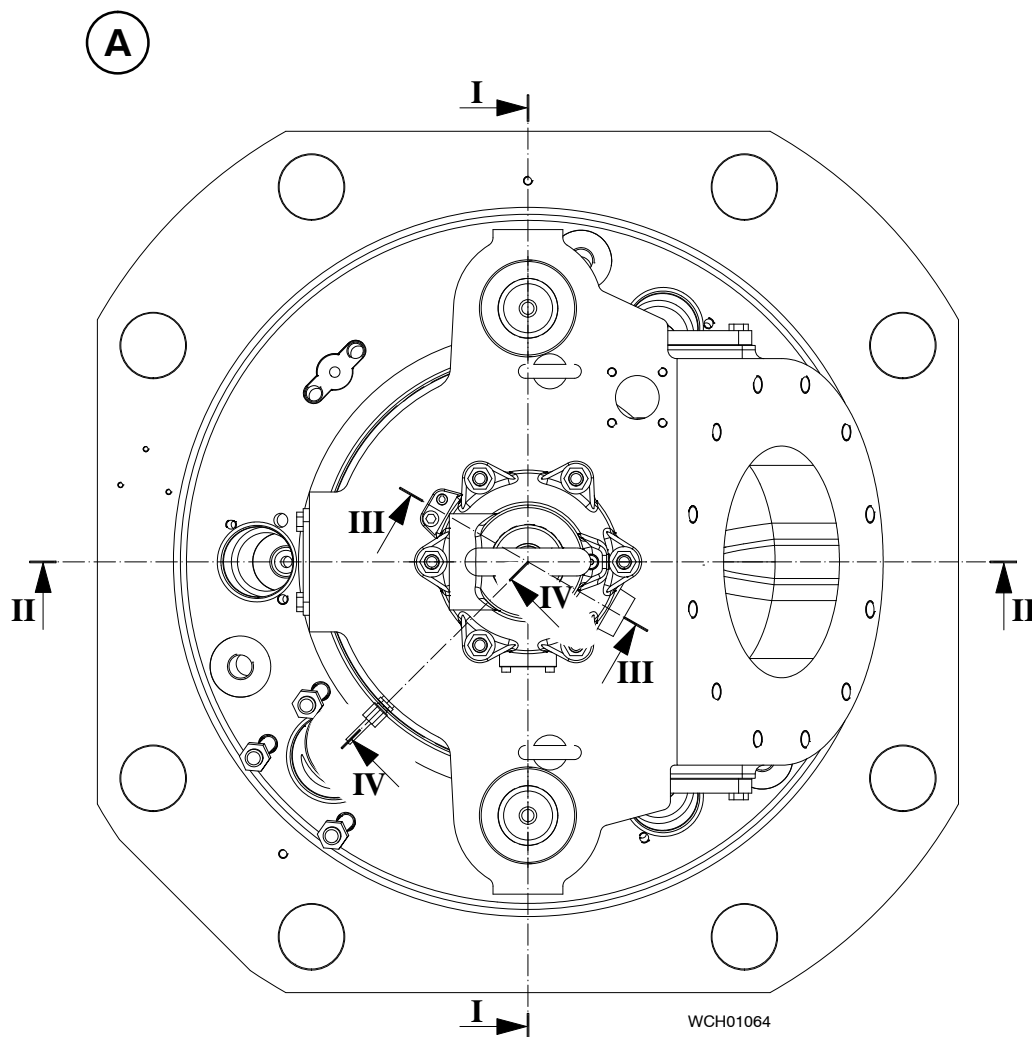

WCH01064

Exhaust Valve

B

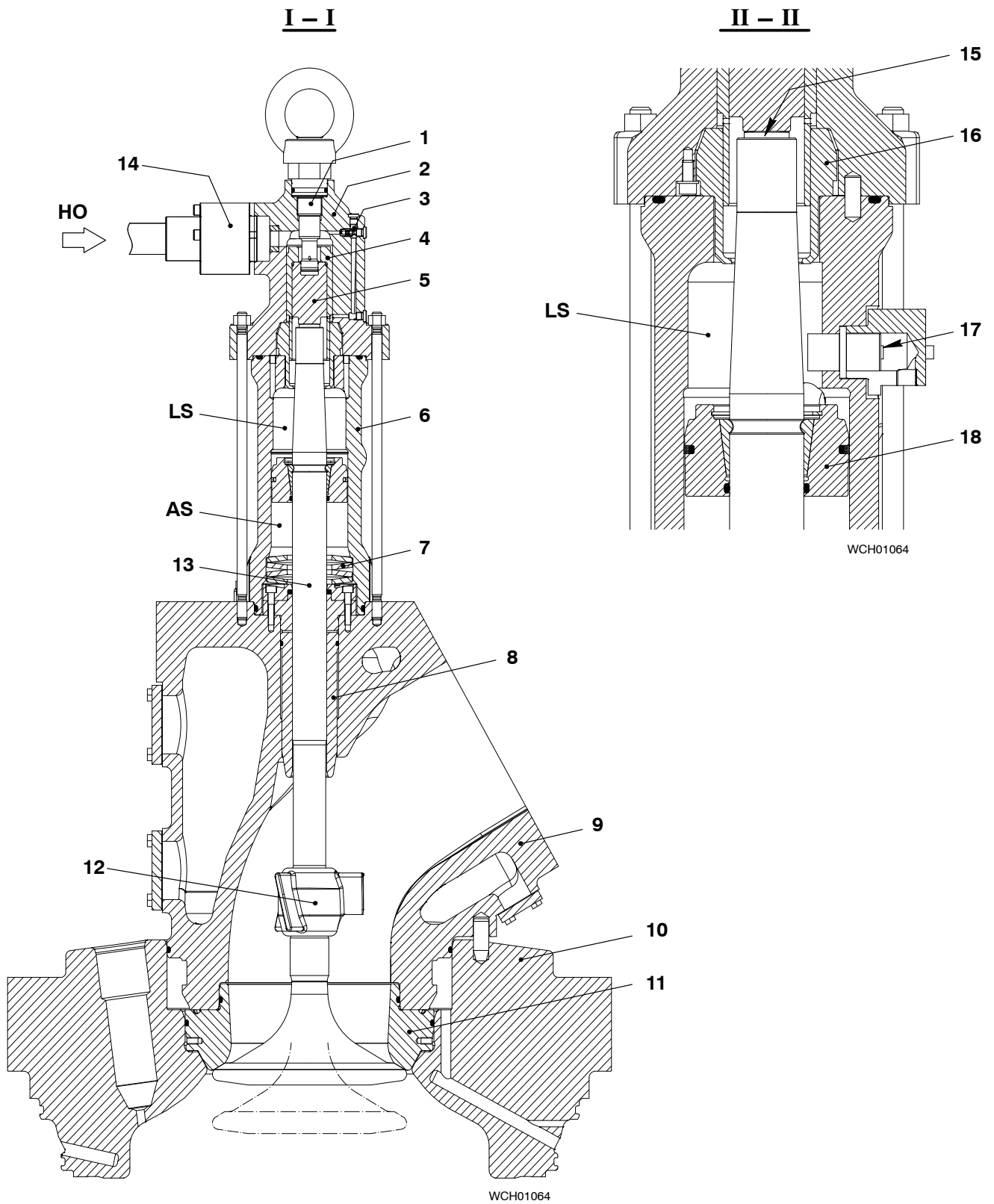

Exhaust Valve

C

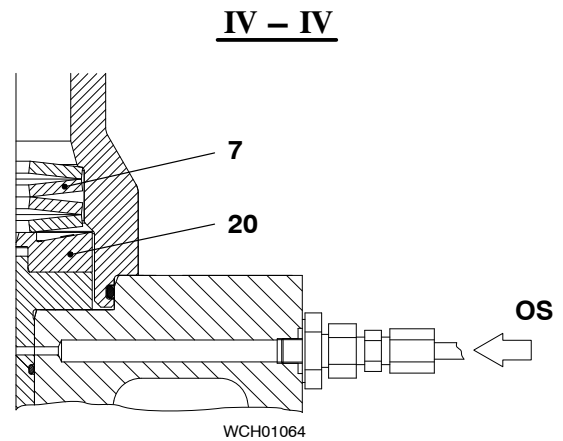
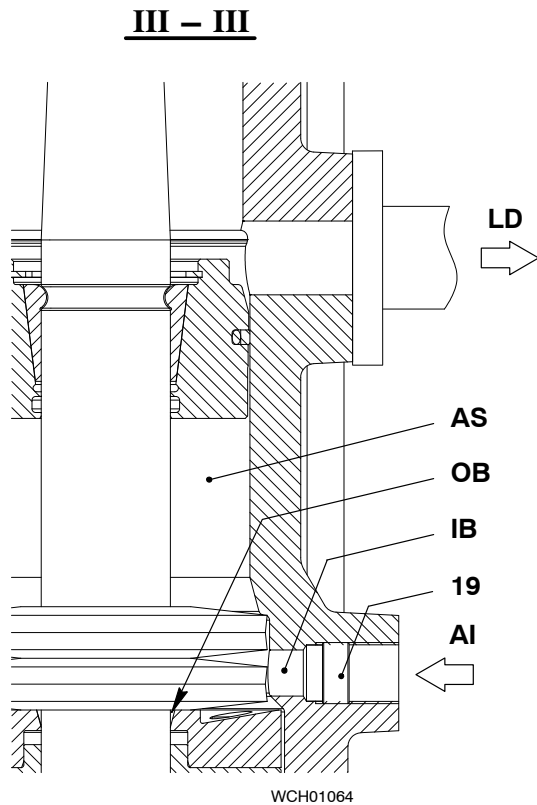

Key to Illustrations:

'A' Location of parts
'B' Exhaust valve
'C' Details exhaust valve

- | | |
|-----------------------------|----------------------------------|
| 1 Damper | 16 Piston guide |
| 2 Upper housing | 17 Valve stroke sensor |
| 3 Orifice | 18 Air spring piston |
| 4 Outside piston | 19 Non-return valve |
| 5 Inside piston | 20 Distance ring |
| 6 Housing | |
| 7 Cup spring | AS Air spring |
| 8 Guide bush | LS Leakage oil collection space |
| 9 Valve cage | HO Hydraulic oil (high pressure) |
| 10 Cylinder cover | LD Leakage oil drain |
| 11 Valve seat | OB Oil bath |
| 12 Rotation wing | IB Inlet bore to air spring |
| 13 Valve spindle | AI Air inlet to air spring |
| 14 Hydraulic oil connection | OS Oil supply to valve guide |
| 15 Thrust piece | |

Crankshaft, Connecting Rod and Piston

Group 3

Axial Damper	3140-1/A1
Connecting Rod and Connecting Rod Bearing	3303-1/A1
Crosshead and Guide Shoe	3326-1/A1

▽ Piston

- with Four Piston Rings	3403-1/A1
- with Three Piston Rings	3403-1/A2
Crosshead Lubrication and Piston Cooling	3603-1/A1

Intentionally blank

Axial Damper

1. General

The engine has a built-in axial damper. The function of the axial damper is to decrease axial vibrations.

The axial damper includes an upper cylinder part 1, and a bottom cylinder part 2 attached with bolts to the last bearing girder. The flange 13 is a part of the crankshaft 9.

2. Function

Bearing oil flows from the oil inlet 'OI' through the orifice 7 into the spaces 'OS' to each side of flange 13. When the crankshaft turns, most of the bearing oil flows between the oil spaces 'OS' through the housing 3. The remaining oil drains through the radial and axial clearances of the gaskets 5 and 6.



Do not operate the engine if there is no oil supply to the axial damper.

3. Monitoring system

The engine has an axial damper monitoring system installed above the end casing at the free end. This system monitors the oil pressure in the oil spaces 'OS' of the axial damper. If the oil pressure decreases below a set value, an alarm is activated (for more data about the setting values, see Alarms and Safeguards [0250-2](#)).

The reason for this alarm must be found and repaired:

- Orifices in the pressure gauge pipes clogged
- Shut-off valves closed in the pressure gauge pipes
- Low oil pressure and / or high oil temperature in the bearing oil system
- Too much wear of the sealing rings, e.g. dirt particles (clearance too large).

Axial Damper

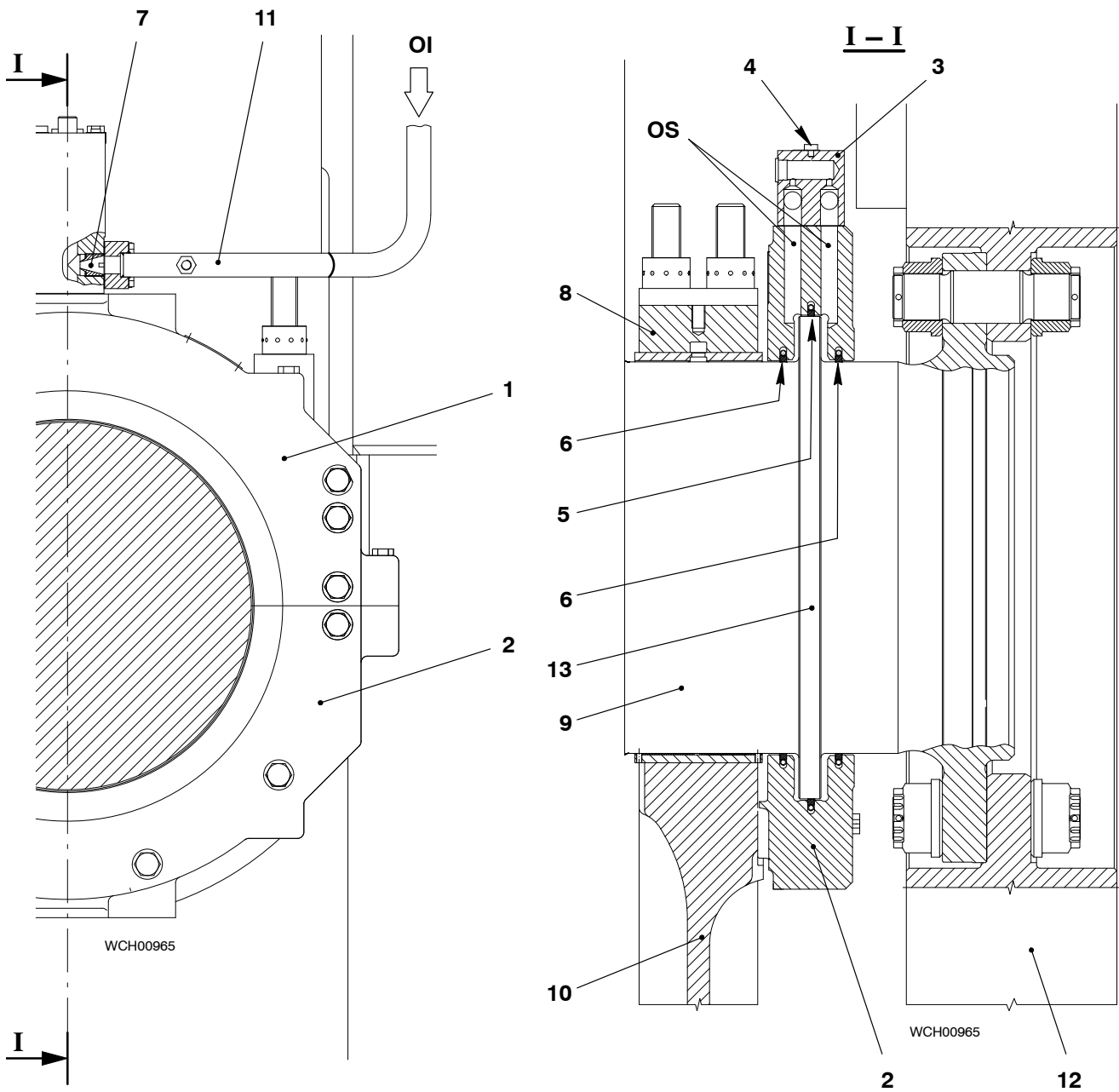
**Key:**

- | | |
|-------------------------|--------------------------------------|
| 1 Upper cylinder part | 10 Bearing girder (part of bedplate) |
| 2 Bottom cylinder part | 11 Oil pipe |
| 3 Housing | 12 Damper (part of crankshaft) |
| 4 Vent screw | 13 Flange |
| 5 Gasket (and spring) | |
| 6 Gaskets (and springs) | |
| 7 Orifice | |
| 8 Bearing cover | |
| 9 Crankshaft | |
| | OI Oil inlet |
| | OS Oil spaces |

Connecting Rod and Connecting Rod Bearing

1. General

The connecting rod connects the crosshead with the crankshaft and converts the linear stroke movement of the piston into a turning movement. Bearing shells (that can be replaced) are installed on the connecting rod 1 for the bottom end bearing (5 and 6) and for the top end bearing (4). The bearing cover for the top end bearing (item 3) is lined with white metal. The locking segments 9 prevent incorrect installation of the crosshead pin.

2. Lubrication

Crosshead lubricating oil flows through the connection 'CO' to the top end bearing, and drillings in the crosshead pin let lubricating oil flow to the guide shoes. Crosshead lubricating oil flows through the oil bore 'OB' in the connecting rod 1 to the bottom end bearing.

Bearing oil flows through the connection 'PC' for piston cooling through related bores in the crosshead pin and piston rod.

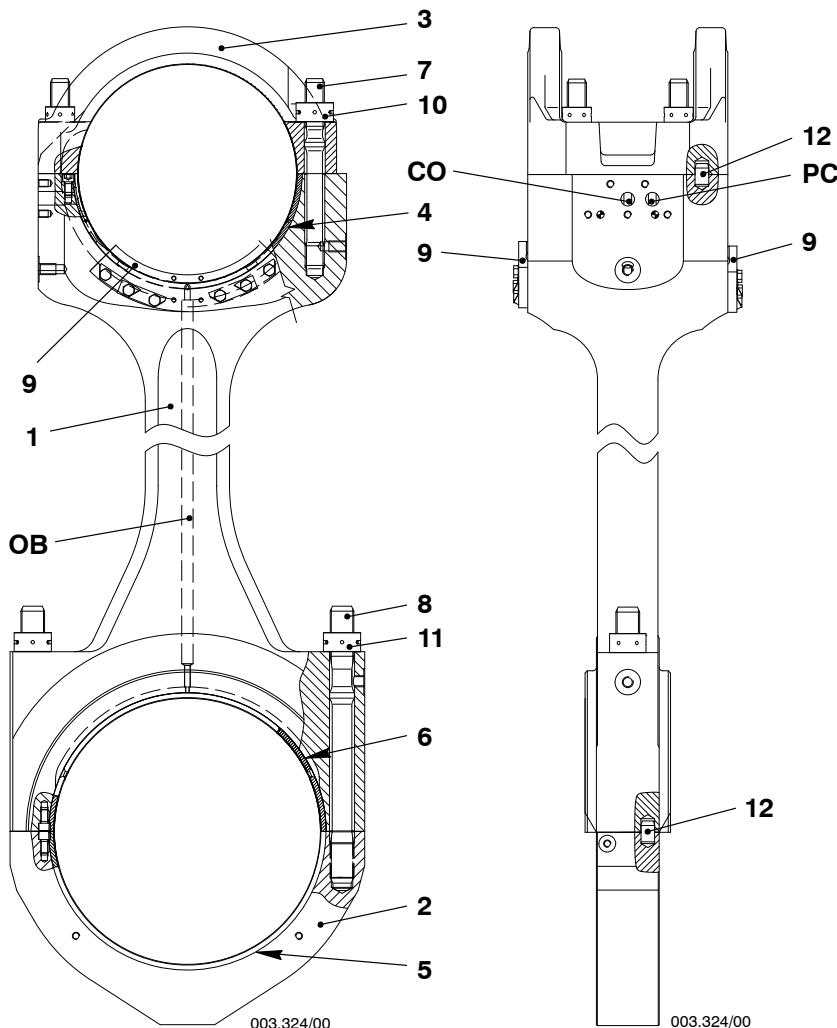

Key:

- 1 Connecting rod
 - 2 Lower bearing cover
 - 3 Upper bearing cover
 - 4 Bearing shell (top end bearing – crosshead)
 - 5 Lower bearing shell (bottom end bearing)
 - 6 Upper bearing shell (bottom end bearing)
 - 7 Studs to top end bearing
 - 8 Studs to bottom end bearing
 - 9 Locking segment
 - 10 Round nut
 - 11 Round nut
 - 12 Cylindrical pin
- CO Crosshead lube oil inlet
 PC Piston cooling oil inlet
 OB Oil bore in connecting rod

Intentionally blank

Crosshead and Guide Shoe

1. General

The crosshead guides the piston rod 5 and absorbs the lateral forces that come from the connecting rod 7.

The piston rod 5 is attached to the crosshead pin 1 with screws. The bearing oil necessary to cool the piston flows through the groove 12 and the bore 'OB' to the piston. The oil 'OR' flows back to the crosshead pin through the oil pipe 10 and returns to the crankcase through the drain 'OD'.

The guide shoes 2 stay in position on the small diameters of the crosshead pin and move up and down in the guide rails 4, which are in the guide ways of the column 9.

The end covers 3 hold the middle parts 11 to the crosshead pin during removal and prevent too much movement.

(A)

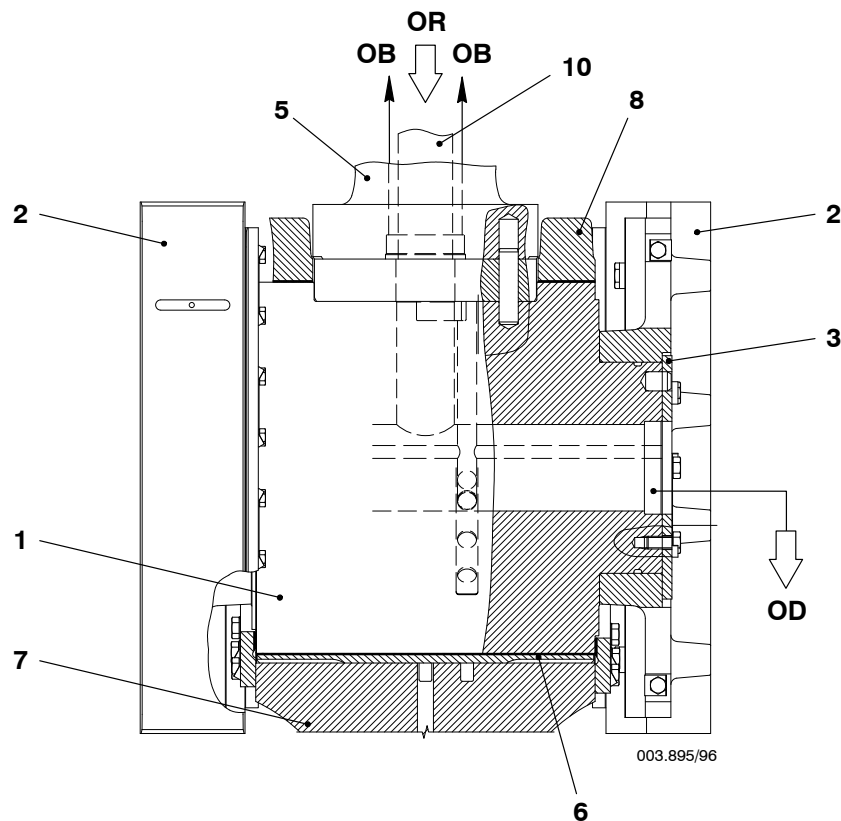

Crosshead and Guide Shoe

B

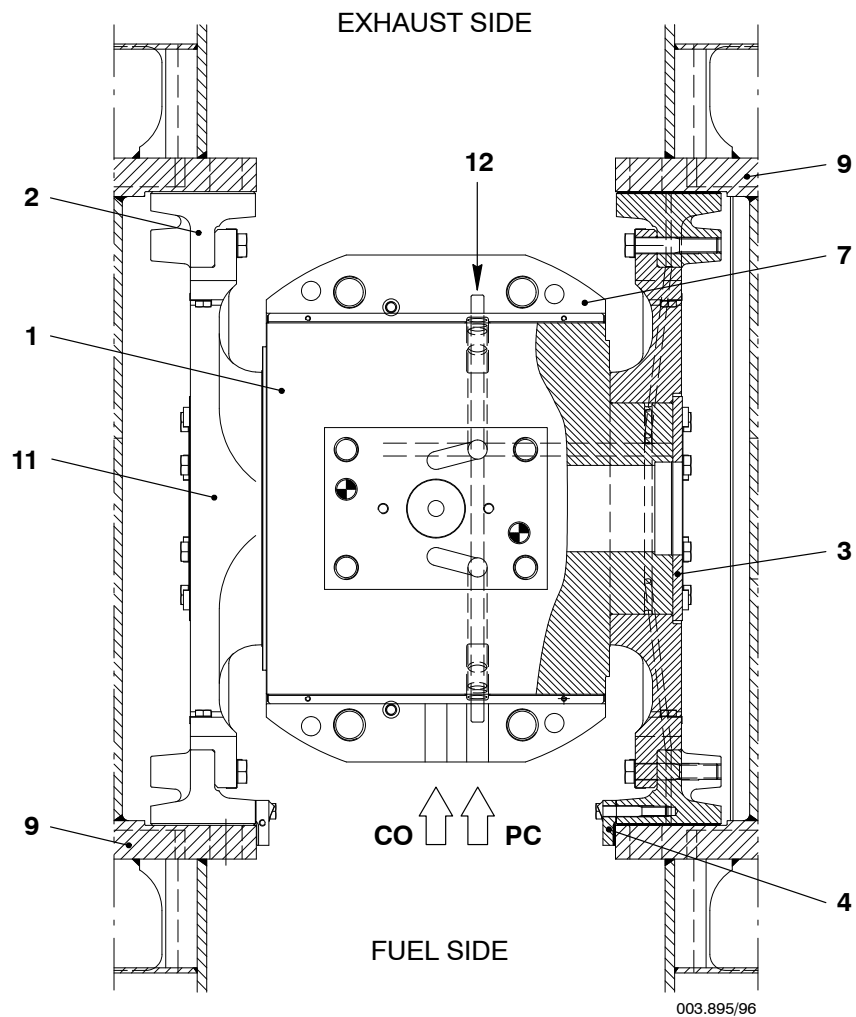
**Key to Illustrations:**

- | | |
|-------------------------------------------------|------------------------------------|
| 1 Crosshead pin | 10 Oil pipe to piston |
| 2 Guide shoe | 11 Middle part |
| 3 End cover | 12 Groove in connecting rod |
| 4 Guide rail | |
| 5 Piston rod | CO Crosshead lubricating oil inlet |
| 6 Bearing shell for top end bearing (crosshead) | PC Piston cooling oil inlet |
| 7 Connecting rod | OD Oil drain into crankcase |
| 8 Upper bearing half for top end bearing | OR Oil return from piston |
| 9 Column | OB Oil flow to piston |

Piston

with Four Piston Rings

1. General

The piston (see Fig 'A') has the parts that follow:

- Piston crown 1
- Piston skirt 3
- Piston rod 5
- The oil cooling components and piston rings 2.

Ten elastic bolts 9 attach the piston crown 1 and piston rod 5 together. The piston skirt 3 is directly attached to the piston rod 5 with screws.

The piston rod 5 is attached to the crosshead pin 8 in a specified position. The compression shim 7 is installed between the piston rod and crosshead pin. The thickness of the compression shim is related to the compression ratio.



Remark: The mark TOP on all piston rings must point up. For more data about the piston rings, see the Maintenance Manual 3425-1.

2. Piston cooling

Lubricating oil is used to cool the piston crown 1. This cooling oil flows from crosshead pin 8 into the two oil inlets 'OI'. The cooling oil then flows through the oil pipe 6 (in the piston rod 5) to the spray plate 4. The cooling oil comes out as a spray 'OS' from the nozzles in the spray plate 4 into the cooling bores of the piston crown. The oil then flows through the oil return 'OR' into the crosshead pin 8 and out through the oil bores to the crankcase.

A

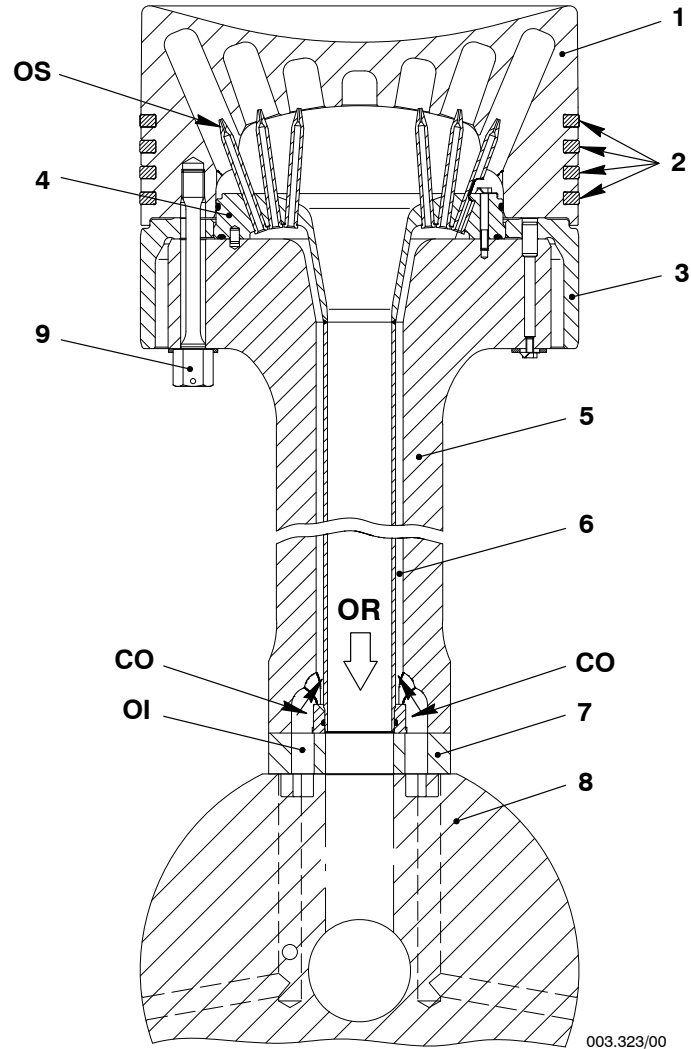

Key to Illustration:		'A' Piston	
1	Piston crown	8	Crosshead pin
2	Piston rings	9	Elastic bolt
3	Piston skirt		
4	Spray plate	OI	Oil inlet
5	Piston rod	OR	Oil return from piston
6	Oil pipe to spray plate	CO	Piston cooling oil
7	Compression shim	OS	Oil spray

Piston

with Three Piston Rings

1. General

The piston (see Fig. 'A') has the parts that follow:

- Piston crown 1
- Piston skirt 3
- Piston rod 5
- The oil cooling components and piston rings 2.

Ten elastic bolts 9 attach the piston crown 1 and piston rod 5 together. The piston skirt 3 is directly attached to the piston rod 5 with screws.

The piston rod 5 is attached to the crosshead pin 8 in a specified position. The compression shim 7 is installed between the piston rod and crosshead pin. The thickness of the compression shim is related to the compression ratio.



Remark: The mark TOP on all piston rings must point up. For more data about the piston rings, see the Maintenance Manual 3425-1.

2. Piston cooling

Lubricating oil is used to cool the piston crown 1. The cooling oil 'CO' flows from the crosshead pin 8 into the two oil inlets 'OI'. The cooling oil then flows through the oil pipe 6 (in the piston rod 5) to the spray plate 4. The cooling oil comes out as a spray 'OS' through the nozzles in the spray plate 4 into the cooling bores of the piston crown. The oil then flows through the oil return 'OR' into the crosshead pin 8 and out through the oil bores to the crankcase.

Piston

with Three Piston Rings

A

**Key to Illustration:****'A' Piston**

- | | | | |
|---|-------------------------|----|------------------------|
| 1 | Piston crown | 8 | Crosshead pin |
| 2 | Piston rings | 9 | Elastic bolt |
| 3 | Piston skirt | | |
| 4 | Spray plate | OI | Oil inlet |
| 5 | Piston rod | OR | Oil return from piston |
| 6 | Oil pipe to spray plate | CO | Piston cooling oil |
| 7 | Compression shim | OS | Oil spray |

Crosshead Lubrication and Piston Cooling

1. General

Lubricating oil keeps the pistons cool. High pressure bearing oil lubricates the crosshead. Each oil system operates independently. The oil from each system flows through a double articulated lever to the crosshead.

2. Crosshead lubrication

The crosshead lubricating oil flows from the oil inlet 17 through the support 4, the bottom lever 6 and the top lever 7 to the connecting piece 8. The connecting piece 8 is attached to the connecting rod 10. The oil enters the ring space 'RS' through the bore 12. The crosshead pin is lubricated through bores in the top end bearing shell 9 (see Fig. 'A'). The oil flows through the bore 'OB' through the connecting rod 10 to the bottom end bearing.

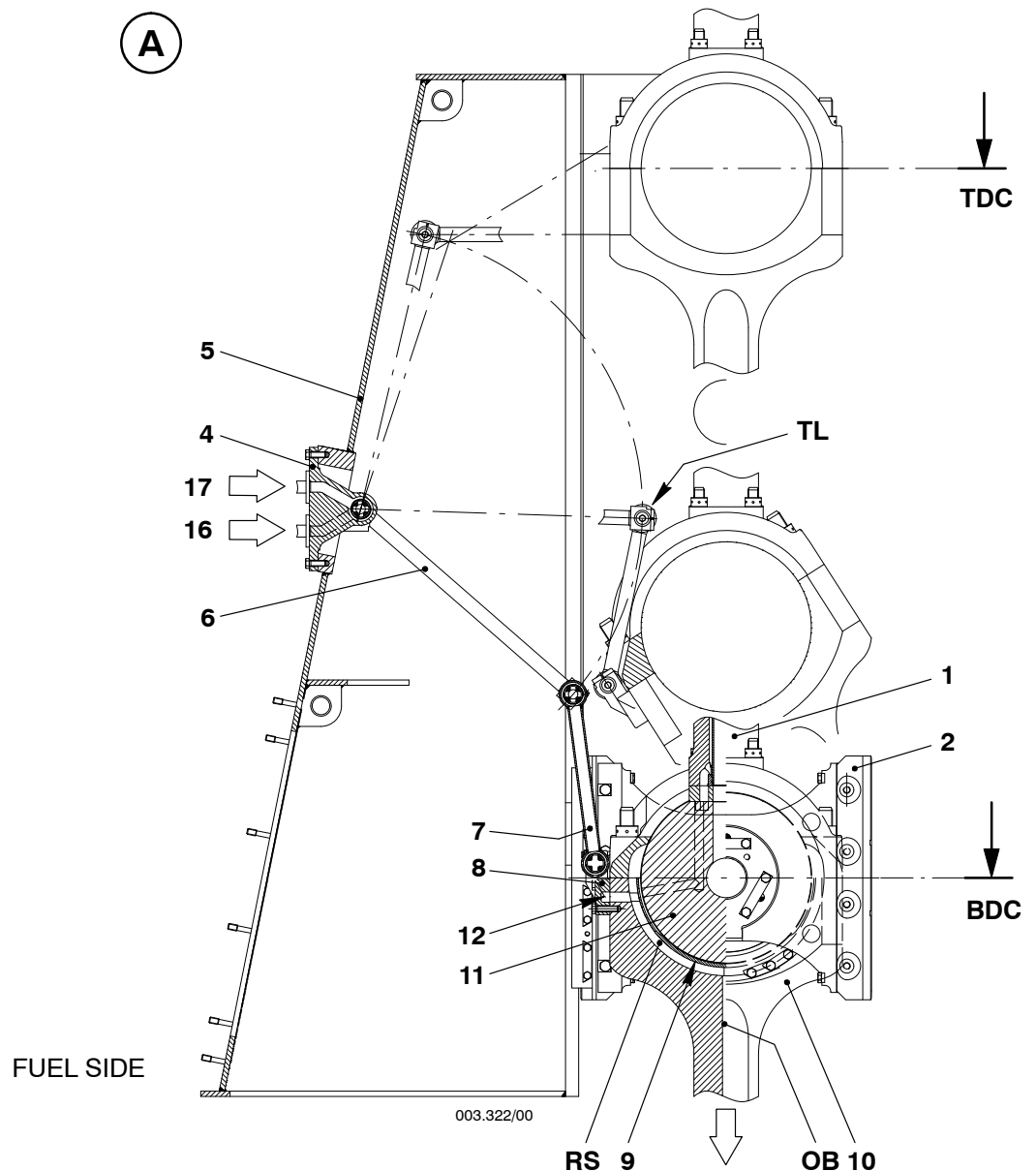

Crosshead Lubrication and Piston Cooling

3. Piston cooling

Bearing oil flows from the oil inlet 16 through the support 4, the bottom lever 6 and the top lever 7 to the connecting piece 8. The oil flows through the bore 13 into the space 15 in the crosshead pin 11, through bores in the top end bearing shell 9 and the bores 14. The oil flows outside the oil pipe 3 through the piston rod 1 to the piston.

The oil then flows inside the oil pipe 3 through the oil return 'OR' to the center bore in the crosshead pin 11 to the crankcase. Some of the piston cooling oil is used to lubricate the guide shoes 2 and the guide shoe pins as shown in Fig. 'B' (for more data, see 3326-1).

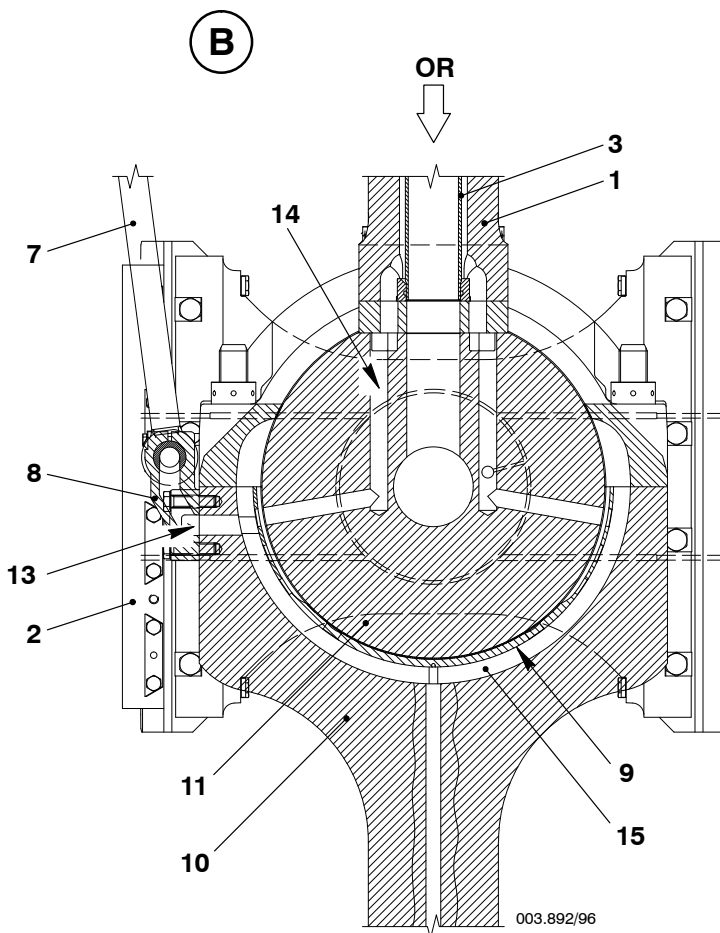

Key to Illustrations:

- 'A' Articulated lever arrangement
'B' Cross section through crosshead

- 1 Piston rod
- 2 Guide shoe
- 3 Oil pipe
- 4 Support
- 5 Column
- 6 Bottom lever
- 7 Top lever
- 8 Connecting piece
- 9 Top end bearing shell
- 10 Connecting rod
- 11 Crosshead pin
- 12 Bore (crosshead lubricating oil)
- 13 Bore (piston cooling oil)
- 14 Bore in crosshead pin
- 15 Ring space (piston cooling oil)
- 16 Oil inlet (piston cooling)
- 17 Oil inlet (crosshead lubrication)

- OR Oil return (piston cooling)
- OB Oil bore (crosshead lubricating oil to bottom end bearing)
- TL Toggle lever
- RS Ring space (crosshead lubricating oil)

▽ Engine Control

- Engine Control System WECS-9520 4002-1/A2
- User Parameters and Maintenance Settings 4002-3/A2
- Regular Checks and Recommended Procedures for WECS-9520 4002-4/A2
- Engine Control 4003-1/A2

▽ Control Diagram

- Designations (Description to 4003-1, 4003-2 and 4003-3) 4003-2/A0
- Control Diagram 4003-2/A3

▽ Control and Auxiliary Systems

- Detailed Control Diagrams with Interfaces to the Plant 4003-3/A3

- Drive Supply Unit 4104-1/A1
- Shut-off Valve for Starting Air 4325-1/A1
- Control Air Supply 4605-1/A1
- Local Control Panel 4618-1/A1
- Pick-up for Speed Measurement 4628-1/A1

Intentionally blank

Engine Control System WECS-9520

Overview

1.	General	1/15
2.	Components	1/15
3.	Engine-related control functions	3/15
3.1	General	3/15
3.2	Fuel pressure control	4/15
3.3	Servo oil pressure setpoint	5/15
3.4	Cylinder lubricating system control	7/15
4.	Cylinder-related control functions	8/15
4.1	General	8/15
4.2	Injection control	9/15
4.3	Exhaust valve control	10/15
4.4	Starting valve control	11/15
4.5	Crank angle sensor	11/15
5.	Communication between WECS-9520 and external systems	12/15

1. General

The Wärtsilä Engine Control System (WECS-9520) is specially designed for two-stroke engines with Wärtsilä Common Rail technology, which includes all engine-related control functions (paragraph 3) and cylinder-related control functions (paragraph 4).

The engine-related control functions are as follows:

- Fuel pressure control
- Servo oil pressure
- Cylinder lubricating system.

The cylinder-related control functions are as follows:

- Volumetric injection control, which includes Variable Injection Timing (VIT)
- Exhaust valve control, which includes Variable Exhaust valve Opening (VEO) and Variable Exhaust valve Closing (VEC)
- Starting valve control
- Crank angle sensor.

Data buses transmit signals between the external systems, the Propulsion Control System (PCS) and the Alarm and Monitoring System (AMS) (paragraph 5). These data buses are the interface between the operator and engine control.

2. Components

Fig. 'A' shows the related components and their connections.

The primary components of the WECS-9520 are as follows:

- The Shipyard Interface Box (SIB) E90 has communication to the external systems. The SIB also contains an FCM-20 module as an online spare.
- Each cylinder has a control box E95.xx, which contains an FCM-20 module for engine and cylinder-related control functions.

The system bus connects all modules.

All control boxes (E90, E95.01 to E95.xx) are installed on the rail unit. The power supply box (E85) is installed near the engine.

Engine Control System WECS-9520

A

DRAWN FOR 6 CYLINDERS

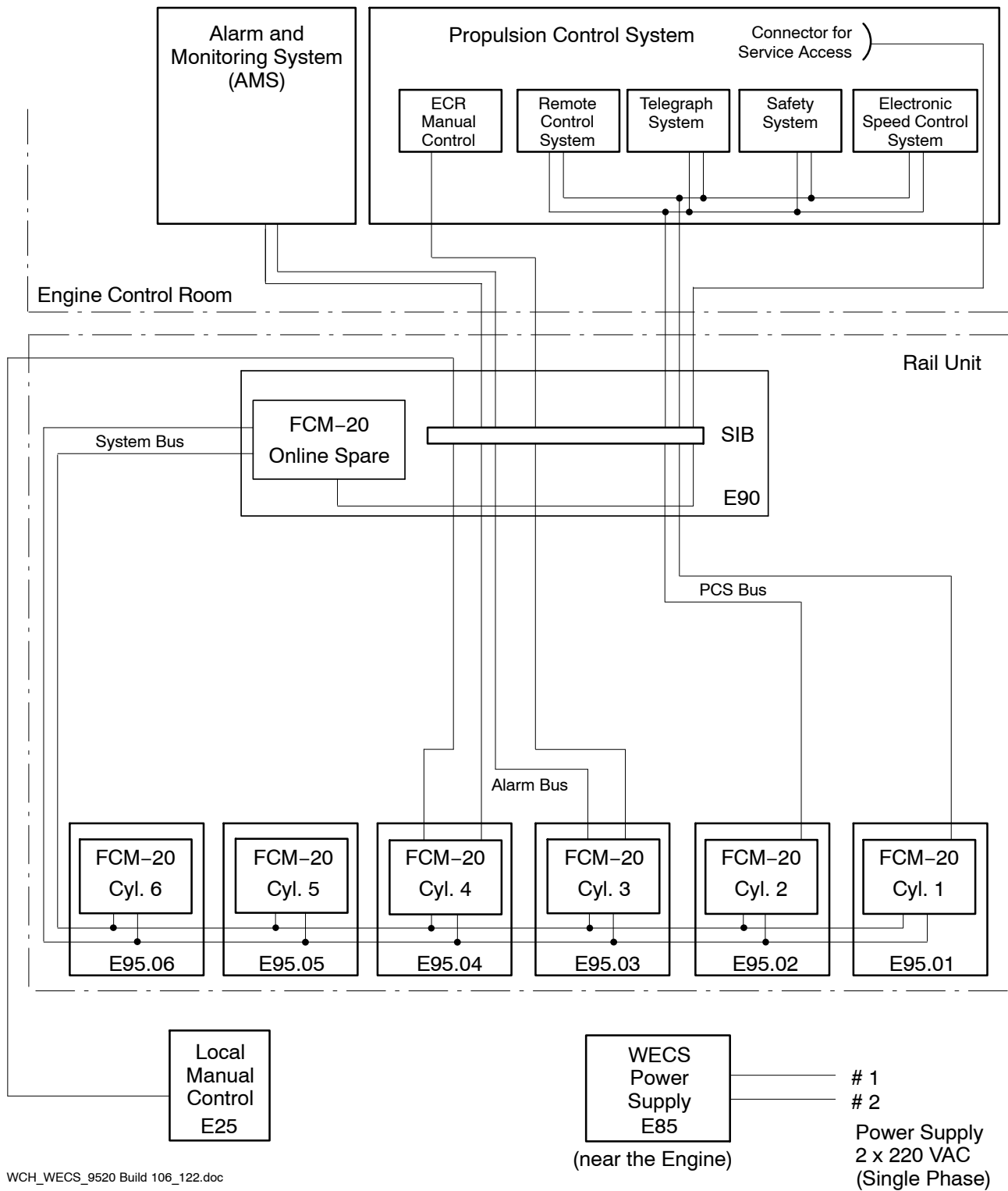

WCH_WECS_9520 Build 106_122.doc

Engine Control System WECS-9520

3. Engine-related control functions

3.1 General

All engine-related control functions are divided within five FCM-20 modules (cylinders 1 to 5) for 5 to 7 cylinder engines. The last and last but one FCM-20 modules are for the control functions of the cylinder lubricating system.

For safety, all important input and output signals of the modules have redundancy. If an FCM-20 module becomes defective, the engine will continue to operate. The power supply also has redundancy (see Fig. 'B').

A defective FCM-20 module must only be replaced with the online spare module.

If the online spare is installed, a new FCM-20 module must be installed in the control box E90. This module will receive an application data download and will then become the new online spare.

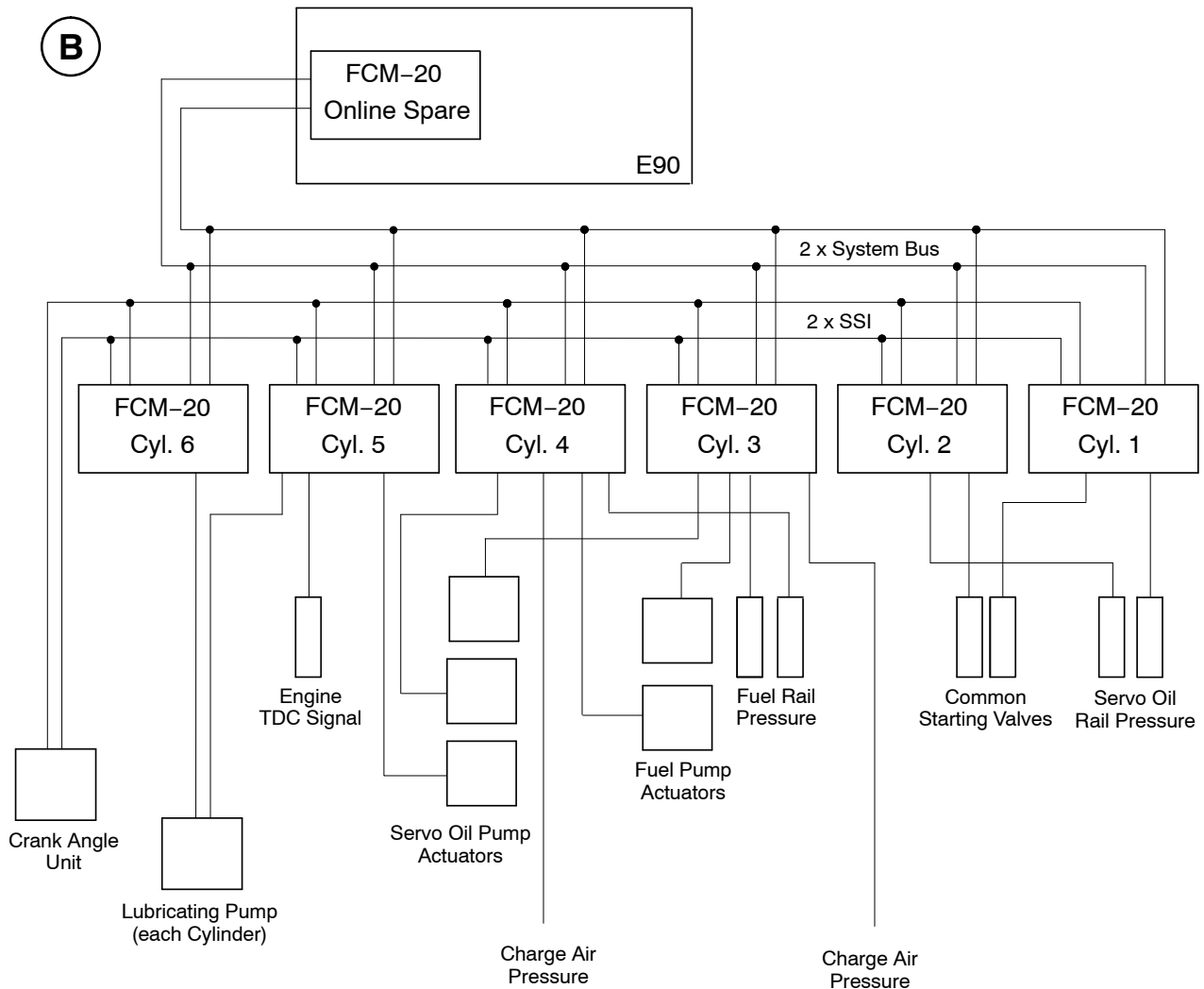

DRAWN FOR 6 CYLINDERS

Engine Control System WECS-9520

3.2 Fuel pressure control (Fig. 'C')

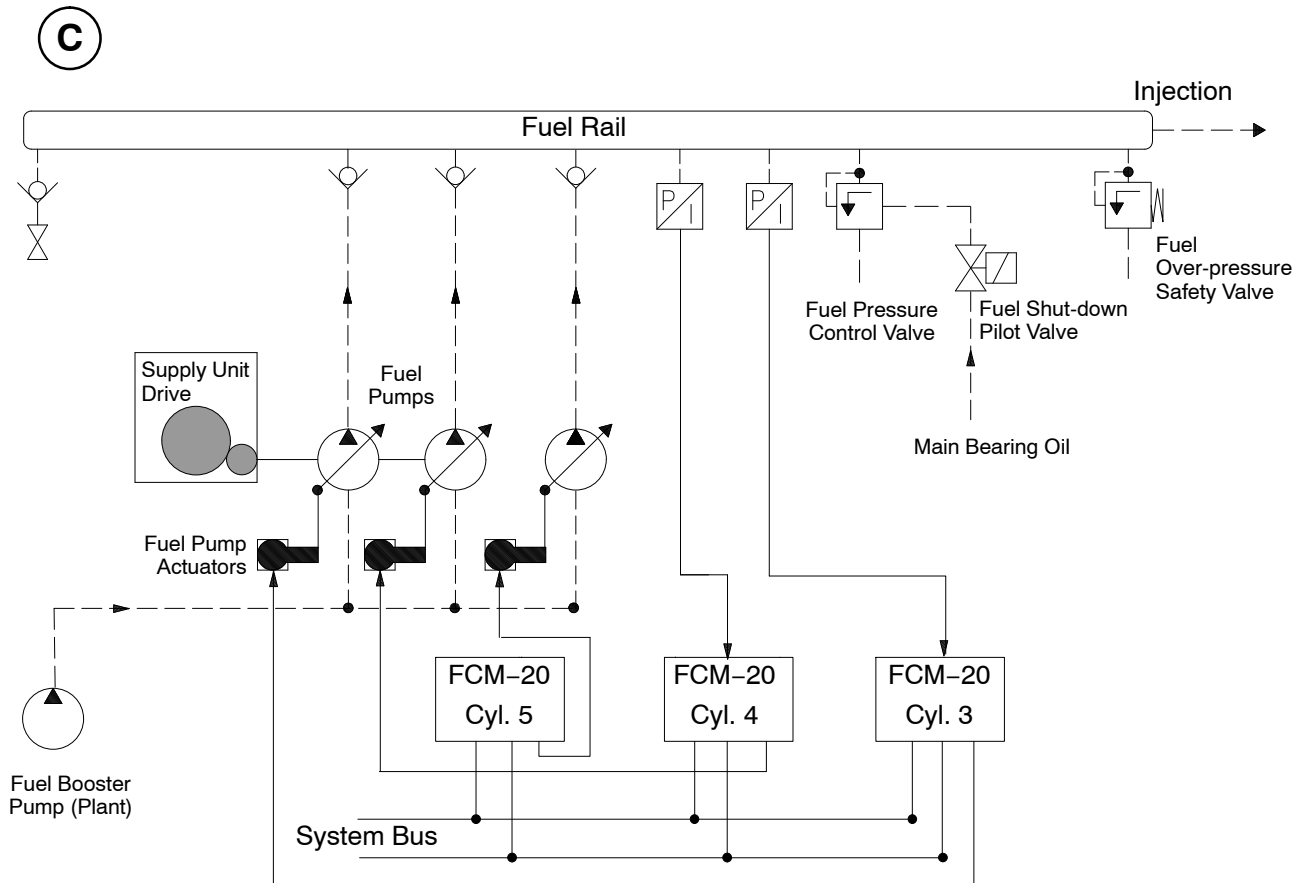

WCH_WECS_9520 Build 106_137.doc

Engine start:

At engine start, the fuel pump actuators are set to the start position.

Engine operation:

The fuel pressure is related to the engine load.

The control loop for the fuel rail pressure is given as follows:

- The WECS-9520 generates a control signal, which is related to the engine speed and the fuel command.
- The signals from the FCM-20 modules control the three fuel pump actuators. Each actuator controls the related fuel pump through the toothed rack.
- Two pressure transmitters measure the fuel pressure. This fuel pressure is feedback to the FCM-20 modules of cylinders 3 and 4.

Shut-down:

At shut-down, the fuel pump actuators are set to position zero and the the safety system activates the fuel shut-down pilot valve.

Engine Control System WECS-9520

3.2.1 Emergency mode

One actuator defective:

If one of the fuel pump actuators is defective its toothed rack stays in position, or a spring moves the toothed rack to the maximum position.

The other actuators will continue to control the fuel pressure. At less than the medium load, the fuel pressure control valve releases unwanted fuel.

3.2.2 Monitored items

Pressure:

The fuel pressure is monitored. If the fuel pressure is out of tolerance, a failure is shown.

Sensors:

The sensors are monitored. If the sensors are out of range or more than the difference, a failure is shown. Also, the LEDs on the FCM-20 modules of cylinders 3 and 4 will flash (see 0850-1 'Failures and Defects of WECS Components').

3.3 Servo oil pressure setpoint (Fig. 'D')

D

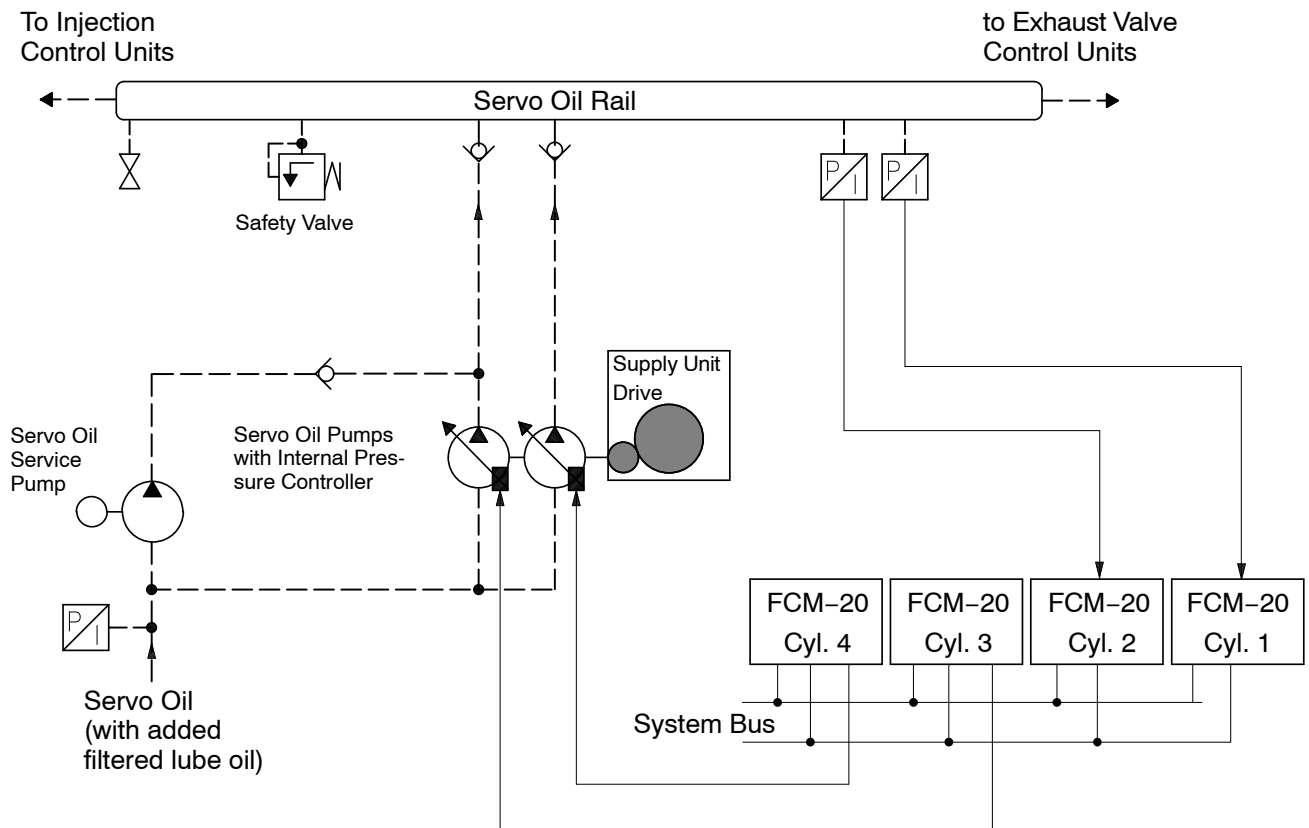

WCH_WECS_9520 Build 106_136.doc

Engine Control System WECS-9520

3.3.1 Pressure setpoint

Each servo oil pump has an internal mechanical pressure controller with an electrical setpoint. A pulse width modulation (PWM) signal gives this setpoint.

The FCM-20 module supplies the setpoint. The setpoint is related to the engine load.

A closed loop control adjusts the pressure decrease in the pipes between the servo oil pumps and the servo oil rail.

Each pressure controller of the two servo oil pumps is connected to an FCM-20 module (cylinders 3 and 4).

3.3.2 Emergency mode

If one servo oil pump becomes defective, the system will continue to operate. The other servo oil pump will continue to supply the necessary pressure to the servo oil rail.

3.3.3 Monitored items

Pressure:

The pressure is monitored. If the pressure out of tolerance, a failure indication shows.

Sensors:

The sensors are monitored. If the sensors are out of range, a failure indication shows and the related LEDs will flash on the FCM-20 modules of cylinders 1 and 2 (see [0850-1](#) 'Failures and Defects of WECS Components').

Engine Control System WECS-9520

3.4 Cylinder lubricating system (Fig. 'E')

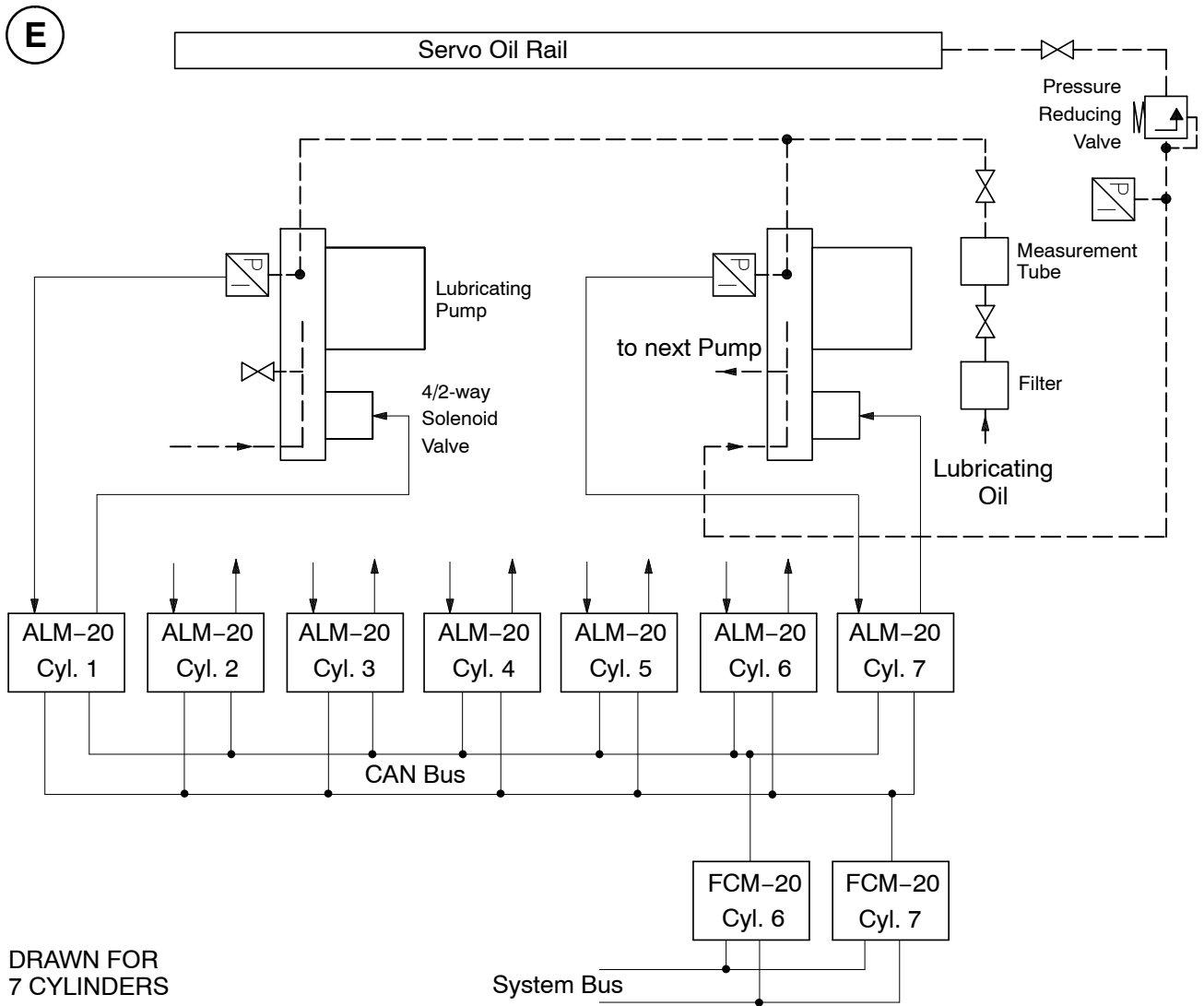

DRAWN FOR
7 CYLINDERS

3.4.1 General

The last and last but one FCM-20 modules control the functions of the cylinder lubricating system. When a control signal is received from an FCM-20 module, each ALM-20 (control unit) operates its related lubricating pump. The dual circuits of the system bus, CAN bus and power supply make sure of redundancy.

3.4.2 Emergency mode

If an FCM-20 module or bus becomes defective, the other FCM-20 module or bus makes sure that control of the cylinder lubricating system continues. A passive failure indication is shown in the WECS-9520 (see also 0850-1).

Engine Control System WECS-9520

4. Cylinder-related control functions

4.1 General (Fig. 'F')

Each cylinder has an FCM-20 module. A redundant system bus gives communication between the FCM-20 modules.

The last and last but one FCM-20 modules receive the crank angle signal from a redundant SSI bus.

If an FCM-20 module becomes defective, the related cylinder is cut out. The other FCM-20 modules continue to operate.

Functions:

- Volumetric injection control (with VIT)
- Exhaust valve control (with VEO/VEC)
- Starting valve control

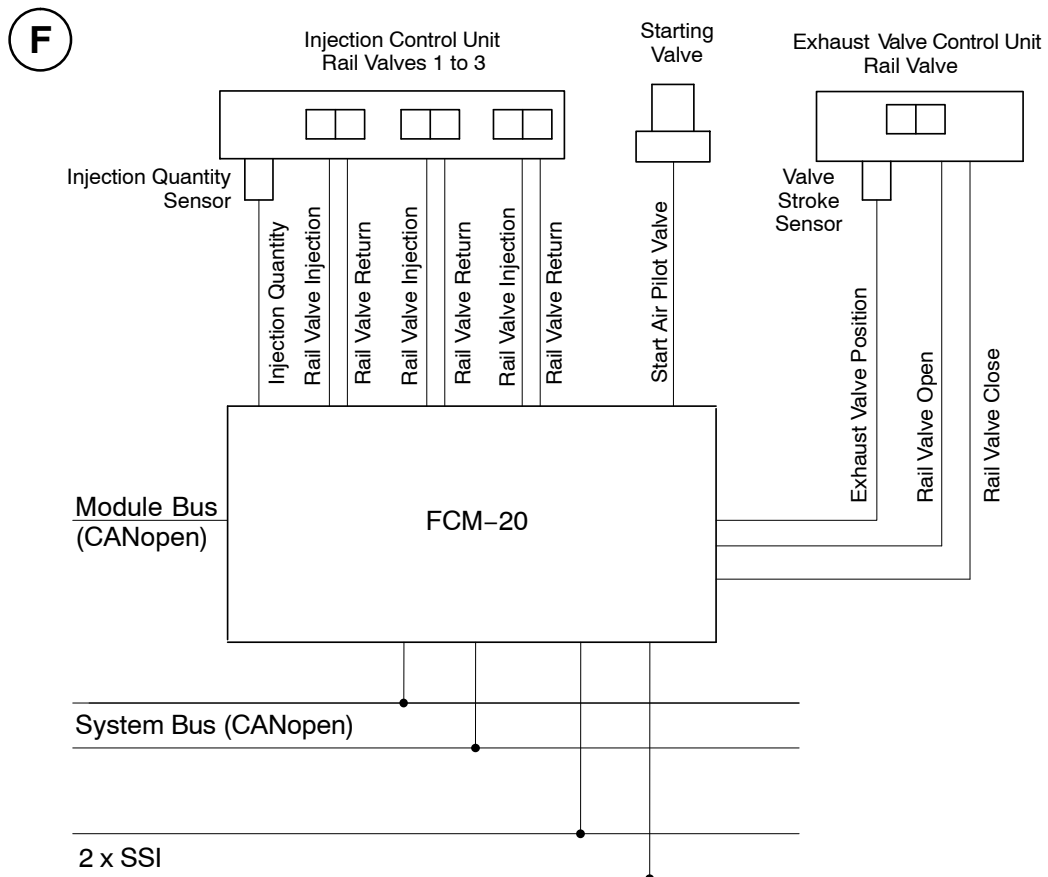

Engine Control System WECS-9520

4.2 Injection control

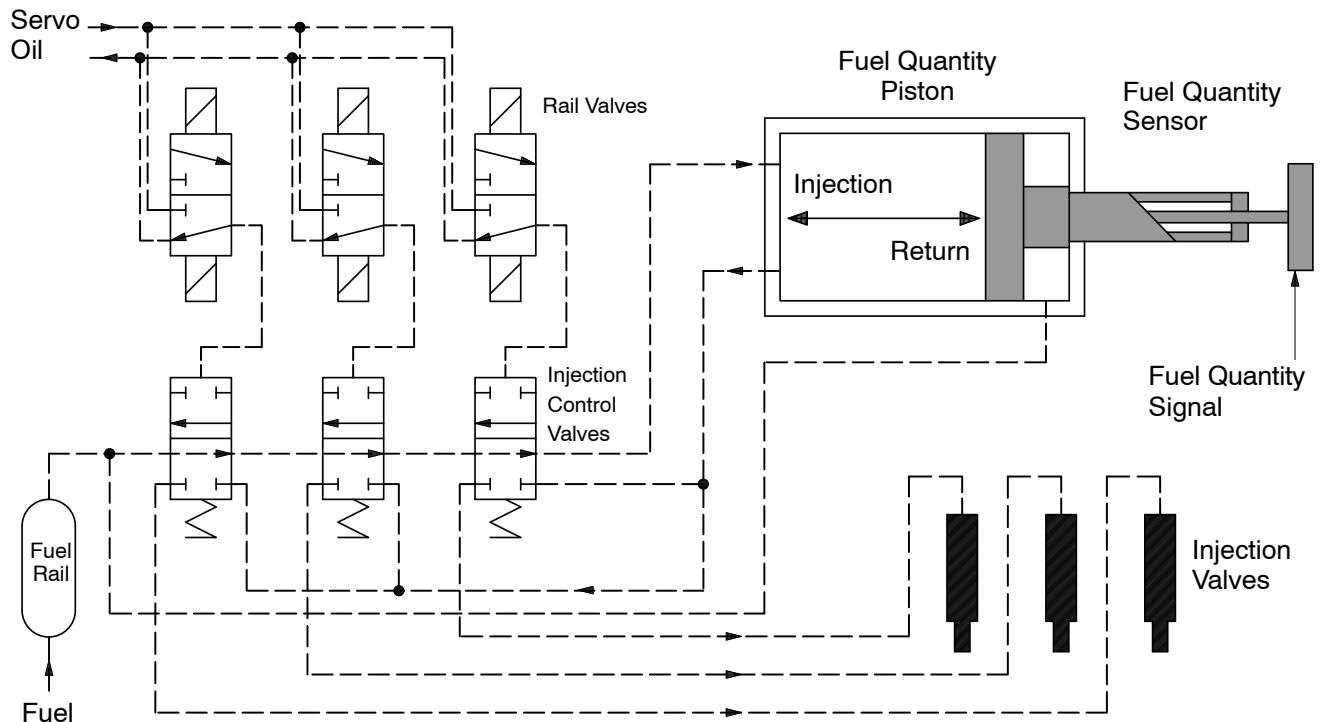

WCH_WECS_9520 Build 106_147.doc

All components are shown in the No Injection position

Injection valve control function:

All injection valves related to the rail valves of a cylinder are controlled independently, but with one common feedback signal for the injected fuel quantity.

Usually, all injection valves are activated at the same time. Special operation modes enable the injection with only one or two injection valves, or with spray intervals (multi-shot patterns) (see also 0280-1 WECS-9520 Injection control).

To improve the fuel spray at low load, one or two injection valves are cut out automatically.

The FCM-20 module is used to amplify control outputs up to the necessary signal strength for the rail valves.

Rail valve ON-time measurement:

The supply of the rail valve is cut off as soon as the valve piston has moved. This is the measured ON-time and is shown in the remote control.

The measured ON-time gives some data about the rail valve condition.

Initial set-pulse:

Because the rail valves are bistable, their initial position is not specified. Thus, at engine standstill, set-pulses are sent to the rail valves at intervals to get a specified position.

Engine Control System WECS-9520

Injection control:

Fuel injection is controlled as follows:

- Data from the crank angle and VIT are used to calculate the injection start
- The rail valves are activated to release the injection.
- The time difference between the injection start signal and the injection start is known as the injection deadtime. The injection start is sensed when the fuel quantity piston moves.
- The stroke of the fuel quantity piston gives the injection quantity. The injection is stopped when the fuel quantity piston is at the calculated stroke.
- The governor calculates the injection quantity. The injection quantity is related to the control signal.
- On the subsequent injection cycle, the calculation of the correct injection time includes the measured injection deadtime.
- The operation of the injection system is monitored at each cycle.

Reversing:

For operation of the the engine in ASTERN, the crank angle is mirrored.

Emergency mode:

If the fuel quantity sensor is defective, the control system changes the fuel command signal from the related FCM-20 module into a time period. The related cylinder is then controlled with timed injection.

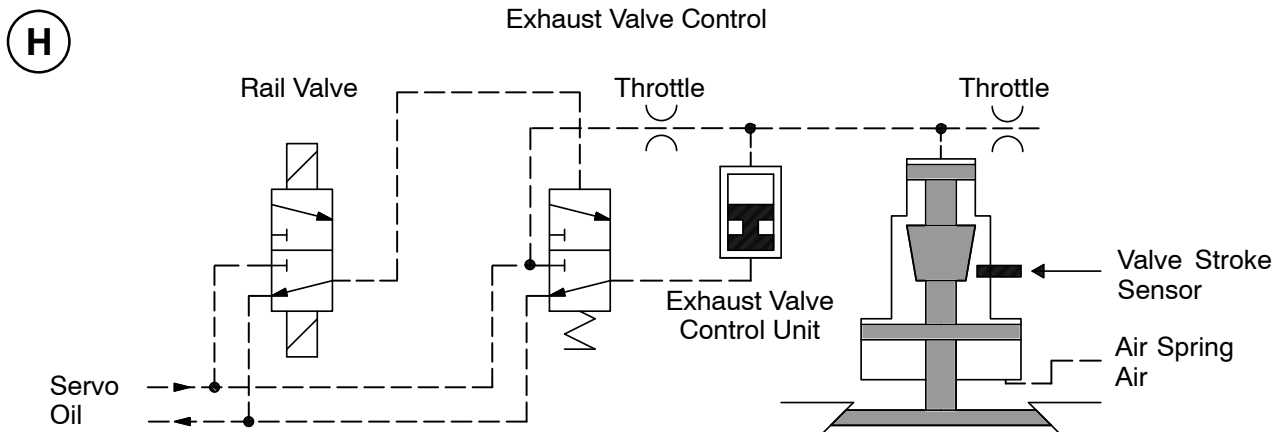
4.3 Exhaust valve control (Fig. 'H')

All components are shown in the Closed position

WCH_WECS_9520 Build 106_146.doc

Exhaust valve function:

The exhaust valve opens and closes once each full turn of the crankshaft. The valve stroke sensor measures the exhaust valve movement.

The FCM-20 amplifies the control outputs up to the necessary signals for the rail valves.

Engine Control System WECS-9520

Rail valve ON-time measurement:

The time between the start signal and the valve piston movement is measured, then shown in the remote control.

Initial set-pulse:

Because the rail valves are bistable, their initial position is not specified. Thus, when the engine has stopped, set-pulses are sent to the rail valves at intervals to get a specified position.

Exhaust valve control:

The exhaust valve movement is controlled as follows:

- The open command of the exhaust valve is calculated in relation to the crank angle and VEO.
- Operation of the rail valve to the open position.
- Measurement of the open deadtime: Displacement time from 0% to 15% of the valve stroke.
- The close command of the exhaust valve is calculated in relation to the crank angle and VEC.
- Operation of the rail valve to the closed position.
- Measurement of the close deadtime: Displacement time from 100% to 15% of the valve stroke.
- After the crankshaft has completed one full turn, the timing for the subsequent cycle is compared to the deadtime of the cycle before and corrected.

Reversing:

For operation of the engine in ASTERN, the crank angle is mirrored.

Emergency mode:

If the valve stroke sensor becomes defective, the exhaust valve control continues with time control for the related cylinder.

4.4 Starting valve control

The FCM-20 module directly opens and closes the starting valve once each full turn of the crankshaft at a specified crank angle until the engine operates.

Reversing:

For starting the engine in ASTERN, the crank angle is mirrored.

4.5 Crank angle sensor

Two crank angle sensors are installed at the free end. The crankshaft operates these crank angle sensors through a coupling. The crank angle sensors give an absolute angle signal (not in increments).

Each of the two signals are transmitted to each cylinder related FCM-20. The signals are not transmitted to the online spare.

After maintenance on the crank angle sensors or their related drives, the signals must be compared to the indication on the flywheel. If there is a difference, this must be adjusted on the remote control.

Crank angle signals:

Each of the two crank angle signals and the TDC signal are compared with each other.

An alarm, slow-down signal or shut-down signal is shown if the three signals do not agree within a specified tolerance.

5. Communication between WECS-9520 and external systems

WECS-9520 gives the data communications that follow to the:

- Propulsion control system
- Alarm and monitoring system (AMS)
- Control panel at the local maneuvering stand
- BACKUP control box in the control room.

The standard version of WECS-9520 has the external communications that follow:

- Two redundant data cables to the remote control
- Two redundant data cables to the AMS
- One data cable to the local control panel
- One data cable to the BACKUP control box in the control room
- One data cable to a connector at the BACKUP control box of the remote control for connection to a notebook for the service personnel.

For the schematic diagrams, see Fig. 'I' and Fig. 'A'.



Remark: The communications between the systems can be different and is related to the approved system manufacturers (see the related documentation).

5.1 Propulsion control system

The propulsion control system is divided into the subsystems that follow:

- The remote control system (RCS)
- The electronic speed control system
- The safety system
- The telegraph system.



Remark: The safety system and telegraph system operate independently and are fully operational if remote control functions become defective.

5.2 Remote control system

The primary functions are as follows:

- Start, stop, reverse
- Automatic slow turning
- Auxiliary blower control
- Transfer control
- Speed setting
- Automatic speed setting program.

Data about the WECS-9520 status is available in the remote control.

This includes measured values of sensors, alarm indications, parameter settings and trend lines (see the documentation of remote control manufacturer).

Engine Control System WECS-9520

The operator can adjust the user parameters e.g. maximum fuel limit, running-in mode and fuel quality setting (FQS).

The operator selects the necessary command on the RCS (e.g. AHEAD or ASTERN). The RCS sends the commands to operate the engine.

The related FCM-20 sends a load signal to the RCS from the average measured fuel quantity signals.

Two charge (scavenge) air signals are transmitted to the RCS through the WECS-9520, thus the signal has redundancy.

If there is a malfunction the WECS-9520 sends an alarm signal to the AMS, or a slow-down/shut-down signal to the safety system.

Parameter setting:

The parameters are divided into two groups:

- User parameters, access without password
- Expert parameters, access with password only.

The operator can adjust the user parameters e.g. maximum fuel limit, running-in mode and fuel quality setting (FQS).

Expert parameters are changed only by service personnel, usually during commissioning. A typical expert parameter is the firing order of the engine, which is set only once. There is a connector for service access in the engine control room.

5.3 BACKUP control box

The BACKUP control box is part of the propulsion control system and installed in the ECR console. The same control functions can be carried out as at the local control panel (see also [4618-1](#)).

5.4 Electronic speed control system

The speed control system is an electronic device that is not part of the WECS-9520.

The electronic speed control system:

- Keeps the engine speed at the necessary value (from the remote control)
- Transfers the fuel command to the WECS-9520.

The fuel quantity limit is related to the charge (scavenge) air pressure and engine protection.

The WECS-9520 receives a fuel command signal from the governor.

This signal is transmitted to all the FCM-20 modules. This is the setpoint for the fuel quantity to be injected.

If the speed control system becomes defective, the engine can operate in:

- LOCAL mode – manual adjustment of the fuel quantity at the local control panel, or
- ECR BACKUP mode from BACKUP control box in control room.



Attention! In BACKUP mode an engine with a controllable pitch propeller (CPP) must be operated with the propeller pitch locked to avoid overspeed.

Engine Control System WECS-9520

5.5 Safety system

The safety system has the primary functions that follow:

- Emergency stop
- Overspeed protection
- Automatic shut-down
- Automatic slow-down.

The WECS-9520 will transmit a signal to the safety system for each malfunction.

For more data, see [0850-1](#) 'Failures and Defects of WECS Components'.

5.6 Telegraph system

The telegraph system is used to transmit maneuvering signals from the bridge to the control room and the local control panel.

Engine Control System WECS-9520

I

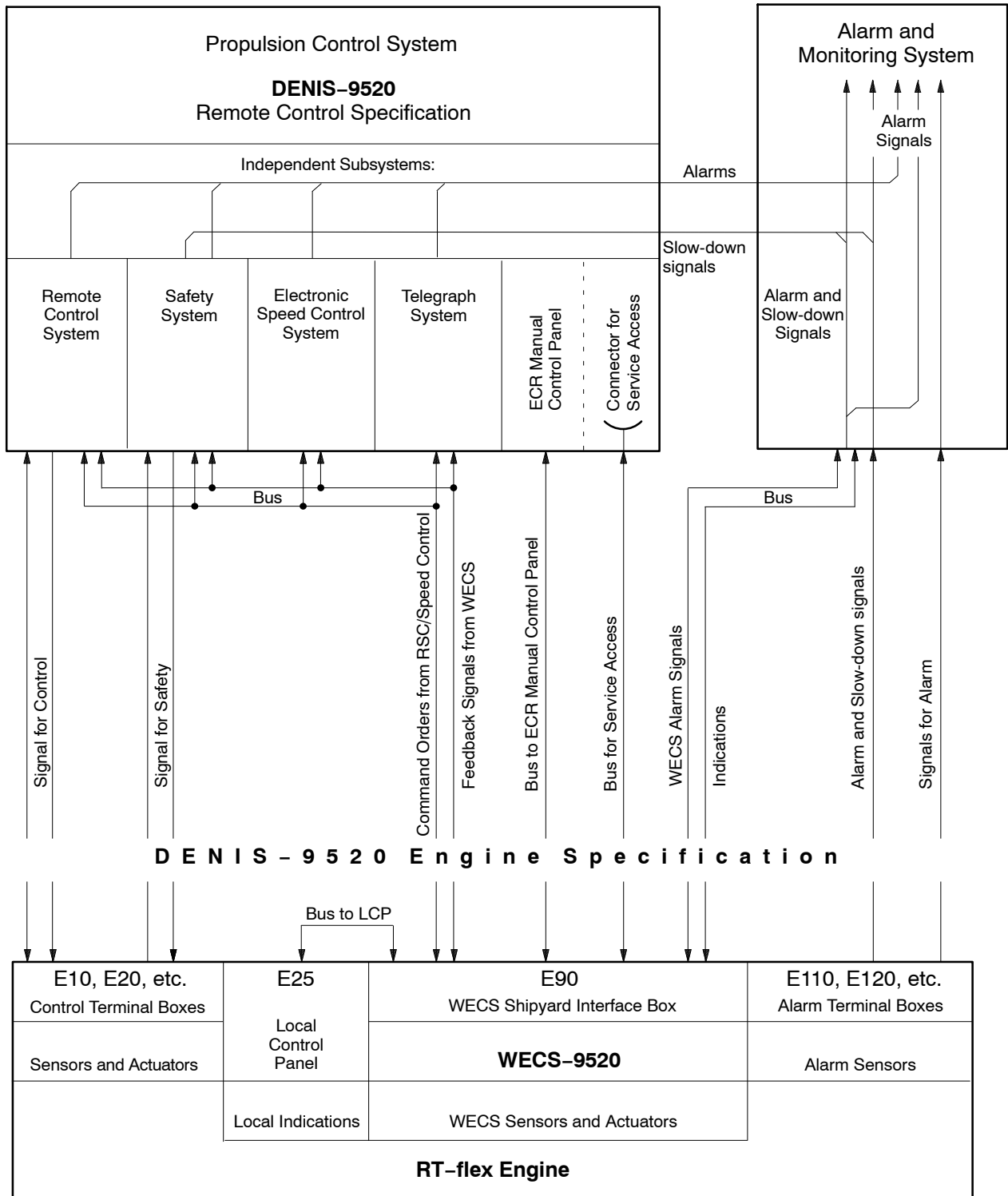

Intentionally blank

User Parameters and Maintenance Settings

1. General

The operator can get access to the user parameter settings without a password.

The operator can get access to the maintenance settings only with a password or a key.

You use the Operator Interface of the remote control to change or set the parameters in the WECS-9520 as follows:

- User parameters in USER
- Maintenance settings in ADJUST.

For data about how to get these areas to change the related values, see the documentation of the remote control manufacturer.

1.1 User parameters

Parameter	Function
FQS (Fuel quality setting)	The FQS can be set to adjust the maximum firing pressure to the nominal value. A negative correction angle will advance the injection start and increase the maximum pressure. A positive correction angle will retard the injection start and decrease the maximum pressure.
VIT on/off	VIT is usually set to on (shown as ON). VIT can be set to off (shown as OFF) for running-in. OFF means injection starts at the nominal angle and is not related to the engine power.
Inj. cut off (Injection cut off)	Can be used to stop fuel injection to a cylinder if necessary (e.g. for liner/piston ring problems or damaged injection system). The exhaust valve stays in usual operation.
Inj. venting (Injection venting)	Injection units of one cylinder, or all cylinders can be vented. The rail valves will be activated at intervals for a specified time. The servo oil service pump must be set to on. This must be done before each engine start after a stop of some hours.
Exv. A/M Cmd (Exhaust valve auto/manual command)	Can be used to manually open and close an exhaust valve when the engine has stopped. Can also be used for tests and venting e.g. after maintenance. Conditions: The servo oil service pump must be set to on, to get pressure in servo oil rail. The air spring pressure must be available.
Start Valves Checking (Common start valves 1/2, enable/disable)	To do checks of the control valves on the shut-off valve for starting air. Set a valve to off to do a check of the other valve.
Heavy Sea Mode	Can be set to on in heavy sea. This function sets the fuel rail pressure to a constant value and is not related to the engine power. Pressure control becomes more stable. Set to off when weather conditions become light and before manoeuvring.
Lubrication (Feed rate)	Adjusts the necessary feed rate in steps of 0.1 g/kWh.

User Parameters and Maintenance Settings

1.2 Maintenance settings

Parameter	Function
Crank Angle (PARA3) Crank angle offset, engine TDC offset	For crank angle settings and checks after maintenance, or when the crank angle sensor unit is replaced. For the input of crank angle differences (mean values) and to do checks of the measured values.
Exv. closing offset (Exhaust valve closing offset)	Cylinder pressure fine tuning in service: Adjustment of compression pressure.
Inj. begin offset (Injection begin offset)	Cylinder pressure fine tuning in service: Permits adjusting of maximum firing pressure.
Inj. correction factor (Injection correction factor)	The injected fuel quantity for each cylinder can be independently decreased to 80%.
Servo oil pump, Pr. setp. tun. (Servo oil pump, pressure setpoint tuning)	Must be done during the initial adjustment of the engine at shop trial. After a servo oil pump replacement, it could be necessary to adjust the pressure set point if one pump gives a No Flow indication at low load. If this occurs, increase the pressure until you get the correct value.

Regular Checks and Recommended Procedures for WECS-9520

1. General

For safety, you must do a check of the redundant control systems and the components in standby mode at regular intervals.

2. Monthly checks

2.1 LOCAL MANUAL CONTROL (Local Control)

⇒ Do an engine start in LOCAL MANUAL CONTROL mode.

3. Quarterly checks

3.1 Level switch

See [8016-1](#) 'Servo oil leakage system' and [8019-1](#) 'Fuel leakage system'.

- ⇒ Do a check of the electrical cable junctions.
- ⇒ Remove the terminal cover from the sensor.
- ⇒ Change the selector switch from MAX to MIN.



Remark: An alarm will be activated and the LED display on the sensor shows red.

- ⇒ Set the selector switch back to the original position.
- ⇒ Install the terminal cover to the sensor.

3.2 Power supply to FCM-20 and ALM-20 modules and fuel pump actuators

⇒ In the power supply box E85, make sure that all related circuit breakers are set to on (see also Location of flex Electronic Components [9362-1](#) and the block diagram in box E85).



Remark: Do the check below only when the engine is stopped, e.g. during the engine start procedure.

- ⇒ Do a check of the main supply switch-over functions as follows:
 - At the main switchboard (plant side), set to off then set to on the AC #1. The WECS-9520 must stay in full operation.

3.3 Pressure switch PS5017C on the shut-off valve



Remark: If the pressure switch PS5017C on the shut-off valve is defective, you cannot start the engine in LOCAL MANUAL CONTROL mode.



Remark: Do the step below when the engine is stopped.

- ⇒ On the WECS-9520 manual control panel, push the LOCAL MANUAL CONTROL button (see [4618-1](#)).
- ⇒ Do the checks of the indications of the turning gear:
 - Engaged = switch open
 - Disengaged = switch closed.

Regular Checks and Recommended Procedures for WECS-9520

3.4 Starting air control valves

- ⇒ In the remote control, set to off one of the starting air control valves activated by FCM-20 of cylinder 1 or 2 (user parameter, function Start Valves Checking).
- ⇒ Do an engine start with starting air (AIR RUN) only, or slow turning.
- ⇒ Do the test procedure again with the other starting air control valve.



Remark: After each start, the WECS-9520 automatically activates the two starting air control valves.

4. Recommended procedure to replace FCM-20 modules



Remark: If possible, do this procedure when the engine has stopped.

- ⇒ Disconnect the power supply to the control box E90.
- ⇒ In the control box E90, disconnect the power supply to the FCM-20 module on the related cylinder.
- ⇒ Remove the on line spare FCM-20 module from the control box E90.
- ⇒ On the related cylinder, replace the unserviceable FCM-20 module with the on line spare.
- ⇒ Install a new FCM-20 module to the control box E90 in the on line spare position. This new FCM-20 module becomes the on line spare.
- ⇒ Connect the power supply to the control box E90 and the related FCM-20 module.
- ⇒ The new on line spare in the control box E90 will receive a download of all application data.

5. Recommended procedure to replace ALM-20 modules



Remark: You can do this procedure during engine operation, or when the engine has stopped.

- ⇒ Replace the defective ALM-20 module.
- ⇒ Do a check of the function of the new ALM-20 module (outer LEDs), see [7218-1 ALM-20 module paragraph 5](#).

Engine Control

Overview

1.	General	1/11
2.	Control functions	2/11
3.	Engine local control	2/11
4.	Engine control system checks	3/11
4.1	Prepare as follows	3/11
4.2	Control air supply unit A	3/11
4.3	Starting up of WECS-9520 control system	4/11
4.4	Safety and alarm system	4/11
4.5	Automatic filter	5/11
4.6	Auxiliary blowers	6/11
4.7	Servo oil system	7/11
4.8	Exhaust valve drive	8/11
4.9	Cylinder lubrication	8/11
4.10	Toothed racks of fuel pumps	9/11
4.11	Fuel system	9/11
4.12	Starting system and start interlock	9/11
4.13	Overspeed system and start procedure	11/11
4.14	Start on fuel	11/11

1. General

The DENIS-9520 (**D**iesel **E**ngine **C**ontrol and **O**ptimizing **S**pecification) and the WECS-9520 (Wärtsilä Engine Control System) are designed so that different remote controls can be used. All nodes are fully specified. Terminal boxes are installed on the engine, to which the cable ends from the control room or from the bridge (related to the remote control) can be connected.

The engine control includes all parts that are necessary for engine safety and to operate and monitor the engine.

Engine control diagram (4003-2):

The engine control diagram is a schematic diagram of all control components and their connections.

All code numbers and designations used in the description that follows are found in the control diagram and 4003-2, Part Code Numbers paragraph 1.

Control and auxiliary systems (4003-3):

On these pages the section diagrams of the engine control are shown in detail. The data give a general view of:

- Connections of the different systems
- Interfaces from the engine to the plant, or to the remote control
- Code designations for the identification of external connections.

Engine Control

2. Control Functions

The engine control lets you do the functions that follow:

- Engine start, running, reversing, maneuvering and stop
- Engine speed adjustment and control
- Partial safeguarding and monitoring the engine.

You do the function checks before you put the engine into operation (see paragraph 4 Engine control system checks).

Interlocks give protection against incorrect maneuvering.

The control media pressures are given in the table below.

Control media	Pressures
Control air from board system	7 bar to 9 bar (see 1)
Control air from starting air system	Maximum 30 bar
Starting air from starting air bottle	Maximum 30 bar (see 2)
Main bearing and piston cooling oil	3.6 bar to 5.0 bar
Crosshead bearing oil	10 bar to 12 bar
Servo oil	100 bar to 200 bar

- 1) The pressure reducing valve 23HA is used to decrease the source pressure (7 bar to 9 bar) to 6.5 bar.
- 2) The pressure reducing valve 19HA is used to decrease the source pressure (30 bar) to 6 bar.

3. Engine local control

The engine can be operated at the local control panel (see also [4618-1](#)).

This mode of operation can be chosen e.g. if there are failures in electronic speed control system or remote control.



Remark: The operator must not leave the local maneuvering stand. The operator must regularly monitor the engine speed so that the fuel supply can be immediately adjusted when necessary.

Prepare as follows:

- ⇒ At the WECS-9520 manual control panel (see [4618-1](#)), push the button LOCAL MANUAL CONTROL (Local Control) for mode transfer to local manual control.

Engine start:

- ⇒ Push the button AUX. BLOWER PRESEL.
- ⇒ Push the button FUEL CONTROL MODE.
- ⇒ Turn the rotary knob to approximately 15% start fuel charge (see display).
- ⇒ Push the button START AHEAD or START ASTERN until the engine operates.
- ⇒ Slowly adjust the rotary knob until the engine operates at the necessary speed. You can see the related value on the display and speed indicator.

Engine Control

Reverse:

- ⇒ Turn the rotary knob to 15% fuel injection quantity (see display).
- ⇒ Push the button START AHEAD or START ASTERN until the engine runs in the applicable direction.



Remark: On ships under way, this procedure can be some minutes, because the propeller is dragged in the opposite sense of rotation.

Engine stop:

- ⇒ Use the rotary knob to decrease the engine speed / load.
- ⇒ Push the STOP button.



Remark: You can also use the ECR manual control panel for the procedure above. The buttons and rotary knob only operate when the related WECS-9520 control panel is selected to be in control (see 4618-1 'WECS-9520 manual control panel').

4. Engine control system checks

If parts of the pneumatic control system were disassembled, removed or replaced during an overhaul, a general operational check must be made before commissioning. The paragraphs that follow give instructions about the procedures.

The item numbers of the valves and the designations that follow relate to those in the engine control diagram 4003-2 and control and auxiliary systems 4003-3.



Attention! Leaks that are found must be repaired during the control system checks.

4.1 Prepare as follows

- ⇒ Open the indicator valves.
- ⇒ Close the shut-off valves on the starting air bottles. Use the handwheel 2.10 to close the shut-off valve for starting air 2.03.
- ⇒ Use the venting valve 2.21 to remove air from the starting air supply pipe.
- ⇒ Use the venting valve 2.27 to remove air from the starting air main distributor.
- ⇒ Release the air in the control air bottle 287HA.
- ⇒ Do a check of the oil quantity and gear lubrication, then engage the turning gear.
- ⇒ Make sure that the servo oil service pump 4.88 is set to off (main switch).
- ⇒ Make sure that the cooling water is chemically treated (see 0760-1 Operating Media, Cooling Water, Treatment).

Engine Control

4.2 Control air supply unit

- ⇒ At connection A2, use the shut-off cock 36HC to open a 30 bar supply to the control air supply.
- ⇒ Make sure that the shut-off cock 36HA is open.
- ⇒ Use the valve 19HA to adjust the air pressure for the air spring air to 6 bar. Do a check of the pressure gages PI4341M and PI4412M.
- ⇒ At connection A1, use the shut-off cock 36HB to open an 8 bar supply from the board supply to the control air supply unit.
- ⇒ Use the valve 23HA to adjust the air spring air and control air pressure to 6.5 bar. Do a check of the pressure gages PI4341M and PI4412M.
- ⇒ Do a check of the air pipes for leaks.
- ⇒ Make sure that air flows to the automatic filter 4.20 and the blocking valve 2.13 on the turning gear, oil mist detector and exhaust waste gate (optional).
- ⇒ Use the pressure reducing valve to adjust the air pressure to the oil mist detector system (if applicable).

4.3 WECS-9520 control system start

- ⇒ In the power supply box E85, set all the circuit breakers to on.
- ⇒ Each time you set a circuit breaker to on, make sure that on all FCM-20 modules, the green LEDs come on.
- ⇒ Make sure that no red LEDs come on.



Remark: The FCM-20 modules are in operation when the SW LED is constantly green.

4.4 Safety and alarm system

- ⇒ Make sure that the WECS-9520, RCS, safety system, alarm and monitoring system are set to on.
- ⇒ On the control room console, push the EMERGENCY STOP button. Make sure that the fuel pressure control valve 3.06 and the fuel shut-down pilot valve 3.08 operate.
- ⇒ Do the procedure above from the local control and the bridge.
- ⇒ Connect the pressure calibration hand-pump to the pipe that has the pressure sensor PS1101S.
- ⇒ Use the pressure calibration hand-pump to increase the pressure to more than the reference pressure given in the table below (e.g. to 10 bar).

Medium	Code No.	Pressure	Action	Time delay
Cylinder cooling water	PS1101S	2.5 bar	Stop	60 sec.
Main bearing oil	PS2002S	2.9 bar	Stop	60 sec.
Piston cooling oil	PS2541-xxS	0.4 bar	Stop	15 sec.
Air spring	PS4341S	4.5 bar	Stop	0 sec.



Remark: The setpoints shown above are for reference only. For the applicable settings, see the Operating Data Sheet [0250-2](#).

- ⇒ Make sure that the pressure switch opens.
- ⇒ Decrease the pressure in the pipe to set the pressure switch to the correct pressure (e.g. 1.5 bar). Make sure that the pressure switch stays open.
- ⇒ Disconnect the pressure calibration hand-pump from the pipe.
- ⇒ Do the steps above for the pressure switches PS2002S, PS2541-xxS and PS4341S.

Engine Control

Passive failures:

- ⇒ To monitor the passive failures, put a resistor in the plug between the connections 2 and 3 of the pressure switches that follow:
 - PS1101S
 - PS2002S
 - PS4341S.
- ⇒ To monitor the passive failures, put a resistor in the plug between the connections 1 and 3 of the pressure switches PS2541S–PS25xxS.

The values of resistors that are related to the the different remote controls are given in the table below:

Supplier	Resistor [kOhm]	Power [W]
KONGSBERG Maritime	10	0.6
SAM / Lyngsø	8.2	0.6
NABTESCO	5.6	0.6

- ⇒ To activate an alarm in the oil mist detection system, do the procedure given in the Oil Mist Detector manual.

Speed pick-ups and TDC:

- ⇒ Do a check of the pick-ups for speed measurement as follows:
 - Use the turning gear to turn the crankshaft.
 - Make sure that the LEDs on the speed pick-ups come on and go off when the TDC mark and a tooth (of the flywheel) move across the proximity sensor face.

Level switches:

- ⇒ Do a check of the level switch in the condensate collectors as follows:
 - Manually operate the float switch to activate a high-level alarm.
- ⇒ Do a check of the level switch in the leakage oil return as follows:
 - Manually operate the float switch to activate a high-level alarm.

4.5 Automatic filter

- ⇒ Make sure that control air is available at the automatic filter.
- ⇒ In the oil pipe upstream of the automatic filter, make sure that ball valve is open.
- ⇒ In the pressure compensating pipe near the oil outlet, make sure that the stop valve is closed.
- ⇒ Make sure that there is a power supply at the control box E92. Set the main switch to on.

Engine Control

⇒ To adjust the settings to those given in the table below (and for other parameter settings), refer to the instructions given in the documentation of the control box E92 (Boll & Kirch electronic controller Type 2200).

Function	Parameter	Adjustment
Flushing interval in hours	P2	1
Flushing interval in minutes	P3	0
Flushing interval in seconds	P4	8



Remark: See also the instructions of the automatic filter manufacturer.

- ⇒ On the control box E92, push the center button on the keypad to start a flush cycle of eight seconds.
- ⇒ Make sure that the motor of the rotation device turns in the correct direction (clockwise when seen from the top).

4.6 Auxiliary blowers



Attention! Before you do the test that follows, make sure that the turbocharger lubricating system is in operation.

- ⇒ Set to on the power supply for the two auxiliary blowers.
- ⇒ On the WECS-9520 manual control panel, push the button LOCAL MANUAL CONTROL (see 4618-1) to get control.
- ⇒ Push the button AUX. BLOWER PRESEL. No shutdown must be active.
 - Auxiliary blower #1 must start immediately.
 - Auxiliary blower #2 must start after two to three seconds.



Remark: This period can be set on the time relay in the auxiliary blower control box.

- ⇒ Do the test again from the ECR manual control panel.
- ⇒ Make sure that the auxiliary blowers turn in the correct direction.
- ⇒ In the terminal box E12, connect the calibration pump (tool) to the pressure transmitter PT4043C (0-6 bar TIER II).
- ⇒ Make sure that the transmitter output (4 mA to 20 mA) is related to the simulated pressure (0 bar to 6 bar TIER II). If necessary adjust or replace the transmitter.



Remark: You can see the value in the operator interface (flexView).

Engine Control

- ⇒ Remove the calibration pump.
- ⇒ In the terminal box E12, connect the calibration pump (tool) and a multimeter to the pressure transmitter PT4044C to simulate scavenge air pressure (0 to 6 bar TIER II).
- ⇒ Remove the calibration pump.

The auxiliary blower start/stop hysteresis (see the table below) is adjusted in the remote control.

IMO TIER II			
Best cost		Best efficiency	
Pressure A [barG]	Pressure B [barG]	Pressure A [barG]	Pressure B [barG]
< 0.45	> 0.65	< 0.80	> 1.00



Remark: In the table above, the term barG is equal to 1 bar at sea level.

4.7 Servo oil system

- ⇒ Start the main bearing oil pump. Make sure that the operation pressure is correctly adjusted.
- ⇒ Start the servo oil service pump 4.88.
- ⇒ The pressure in the servo oil rail 4.11 must be approximately 80 bar to 100 bar. You can see the related value on the WECS-9520 manual control panel display.
- ⇒ Make sure that the pressure in the pulse lubrication system is 50 bar. If necessary, use the pressure reducing valve 8.11-1 to adjust the pressure.
- ⇒ When the servo oil system is pressurized, set the servo oil service pump 4.88 to off.

Engine Control

4.8 Exhaust valve drive, position feedback

- ⇒ In the flexView, manually open the exhaust valve 4.01 on cylinder #1 (see [4002-3](#) paragraph 1.1 parameter Exv. A/M Cmd).
- ⇒ When the exhaust valve opens, record the value (mA) shown in the flexView EXV, of fields Open position sensor 1.
- ⇒ On cylinder #1, close the exhaust valve 4.01.
- ⇒ When the exhaust valve is closed, record the value (mA) shown in the remote control, EXV in the field Open position sensor 1.
- ⇒ Do the procedure given above for each exhaust valve.



Remark: The values shown must be almost the same for all cylinders ± 1.5 mA. If not, an exhaust valve is not fully open or the sensors are defective.

- ⇒ In the flexView, set the parameters of each exhaust valve drive to AUTO.

4.9 Cylinder lubrication

- ⇒ Make sure that all ALM-20 modules are electrically connected. The green power LED comes on when the power supply is set to on and the lubricating system software operates correctly (no red LEDs).
- ⇒ Make sure that the stop valve 4.30-5 is open.
- ⇒ Make sure that the servo oil pressure is 50 bar. If necessary, use the pressure reducing valve 8.11-1 to adjust the pressure. The value is shown on the pressure gage PI2041L.
- ⇒ Make sure that there is a supply of lubricating oil and the duplex filter 8.17 is clean.
- ⇒ Make sure that the ball valve is open in the oil pipe downstream of the measurement tube 8.19.
- ⇒ In the lubricating pumps, fully move the shut-off valve to the operation position.
- ⇒ Bleed the duplex filter 8.17, measurement tube 8.19 and all lubricating pumps 8.06 (see [7218-1](#), Cylinder Lubrication, paragraphs 4.3 and 4.4).
- ⇒ In the field MANUAL LUBRICATION ON CYL., select the related cylinder number (in the operator interface), or activate MANUAL EMERGENCY on the 4/2-way solenoid valve.
- ⇒ Look through the scavenge ports to make sure that lubricating oil flows down the cylinder liner from the lubricating quills.



Remark: The number of lube pulses can be changed to those necessary for operation conditions (e.g. 20 lube pulses to do a feed check, or to bleed the system). In the flexView, see the field LUBRICATION – MANUAL LUB. NR. OF CYCLES.

Engine Control

4.10 Toothed racks of fuel pumps

- ⇒ Make sure that the toothed racks are installed correctly, see the Maintenance Manual 5801-1, Adjusting the regulating linkage.
- ⇒ Make sure that the toothed racks move freely over the full range of travel.



Do not set to on actuators that are disconnected from the toothed racks, or disconnect a toothed rack from actuators that have power. Damage to the actuators can occur.

4.11 Fuel system

- ⇒ Start the fuel booster pump 3.15.
- ⇒ Make sure that the pressure retaining valve 3.53 is set to get a pressure difference of 3 bar to 5 bar. The pressures upstream and downstream of the pressure retaining valve are shown on the pressure gages PI3421L and PI3431L. For the setting values, see 0250-1 Operating Data Sheet.
- ⇒ The fuel shut-down pilot valve 3.08 must be closed (i.e. not energized).
- ⇒ On the fuel pressure control valve 3.06, make sure that the knurled screw is fully tightened to its bottom stop.
- ⇒ Remove the plug 3.39 and the plug on the stop valve 3.40 (between servo oil rail and fuel rail).
- ⇒ Connect the pipe (tool 94583) between the plug 3.39 and the stop valve 3.40.
- ⇒ Start the main bearing oil pump and the servo oil service pump 4.88.
- ⇒ Open the stop valve 3.40. The fuel rail must now be pressurized with approximately 100 bar.
- ⇒ In the flexView, select Inj. venting to bleed the injection system (see 4002-3 paragraphs 1 and 1.1).
- ⇒ Push all EMERGENCY STOP buttons, to activate a shut-down.
 - The fuel pressure control valve 3.06 must open immediately, and the pressure in fuel rail 3.05 must decrease to 0 bar. You can see the pressure decrease on the WECS-9520 manual control panel display (see 4618-1 paragraph 2).
- ⇒ Close the stop valve 3.40.
- ⇒ Release the pressure in the fuel rail 3.05.
- ⇒ Remove the pipe (tool 94583) between the plug 3.39 and the stop valve 3.40.
- ⇒ Install the plug 3.39 and the plug on the stop valve 3.40.
- ⇒ Set the EMERGENCY STOP button so that the system can operate again.

4.12 Starting system and start interlock

Start interlock:

- The shut-off valve for starting air 2.03 is closed and air is released from the starting air supply pipe.
- The turning gear is engaged.
- ⇒ Loosen the pipe to valve unit **[E]** at the connection E6. No air must come out of the pipe.
- ⇒ Slowly disengage turning gear. Make sure that no air comes from the pipe when:
 - The turning gear pinion is engaged
 - The axial clearance between the flywheel teeth (crank angle mark) and the turning gear pinion is not more than 10 mm.



Remark: Do the check above each time you engage / disengage the turning gear.

- ⇒ Connect the pipe to connection E6.

Engine Control

Shut-off valve for starting air:

- ⇒ Remove the shuttle valve 115HA from valve unit **E**. Make sure that the three O-rings stay in position.
- ⇒ On the WECS-9520 manual control panel, select LOCAL MANUAL CONTROL (see 4618-1).
- ⇒ Push the button AIR RUN.
- ⇒ Make sure that the two solenoid valves ZV7013C and ZV7014C are energized (use a screwdriver or a magnet tester).
- ⇒ Make sure that control air comes out of each pipe from the solenoid valves ZV7013C and ZV7014C in valve unit **E** (see 4003-2 Control Diagram).
- ⇒ Make sure that:
 - The shut-off valve for starting air 2.03 is manually closed.
 - There are no active shut-down signals released.
 - The turning gear is disengaged.
 - The auxiliary blowers are set to off (AUX. BLOWER STOP button).
- ⇒ On the WECS-9520 manual control panel, select START AHEAD.
- ⇒ Make sure that the indications No Aux. Blower Running and Start Interlock are shown on the WECS-9520 manual control panel. No start command is released.
- ⇒ Select START ASTERN.
- ⇒ Make sure that the indications No Aux. Blower Running and Start Interlock are shown on the WECS-9520 manual control panel. No start command is released.
- ⇒ Select AUX. BLOWER PRESEL.
- ⇒ Do the tests for START AHEAD and START ASTERN as given above.
- The auxiliary blowers start and control air comes out of each pipe from the solenoid valves ZV7013C and ZV7014C in valve unit **E**.
- ⇒ Make sure that the O-rings are in position in the shuttle valve 115HA.
- ⇒ Install the shuttle valve 115HA to valve unit **E**.

Turning gear interlocks:

- ⇒ Engage the turning gear.
- ⇒ Make sure that the pressure switch PS5017C (set-point 2 bar) and the switch ZS5016C are not activated (open contact).
- ⇒ Make sure that the indication Turning Gear Engaged is shown on each WECS-9520 manual control panel (i.e. on the ECR console and the local maneuvering stand).



Attention! Make sure that the engine is ready for service, the shut-off valve for starting air 2.03 is closed and the starting air supply pipes have no pressure.

- ⇒ On the WECS-9520 manual control panel, push the button LOCAL MANUAL CONTROL (see 4618-1 paragraph 2).
- ⇒ Push the button START AHEAD.
- ⇒ Make sure that Start Interlock is shown on each WECS-9520 manual control panel. No start command is released.
- ⇒ Do the test from the ECR manual control panel and with the remote control.
- ⇒ Disengage the turning gear.
- ⇒ Make sure that Start Interlock disappears from each WECS-9520 manual control panel. The Start command is cancelled in the remote control.

Engine Control

4.13 Overspeed system and start procedure

- ⇒ Close venting valves 2.21 and 2.27. Put handwheel 2.10 of shut-off valve for starting air 2.03 in position AUTOMAT and open shut-off valves at the starting air bottles.
- ⇒ Make sure that the turning gear is disengaged.
- ⇒ Set the overspeed limit to approximately 30 rpm.
- ⇒ Make sure that the safety system checks are done and the fuel shut-down pilot valve 3.08 operates correctly.
- ⇒ Set to on the main bearing and crosshead oil pumps.
- ⇒ Set to on the cooling water pumps.
- ⇒ Set to off the servo oil service pump 4.88.
- ⇒ Push the button LOCAL MANUAL CONTROL at WECS-9520 manual control panel (see [4618-1](#)).
- ⇒ Push the AIR RUN button to start the engine with air only.
- ⇒ When the engine is at a speed of 30 rpm, the overspeed monitor will activate a shut-down.
- ⇒ Make sure that the fuel pressure control valve 3.06 opens and that the pressure in fuel rail 3.05 decreases immediately. You can see the pressure decrease on the WECS-9520 manual control panel.
- At the same time the fuel pump actuators move the regulating linkages to the position 0.
- ⇒ Set the overspeed monitor so that the system can operate again.
- ⇒ If these overspeed tests are satisfactorily completed, set the overspeed monitor in the safety system to the nominal speed +10%.

4.14 Start on fuel

- ⇒ Make sure that the engine is ready for operation (see [0110-1](#) 'Checks and preparations').
- ⇒ Push the button AIR RUN to turn the engine.
- ⇒ Push the button FUEL CONTROL MODE.
- ⇒ On the local control panel, use the rotary knob to set the fuel injection quantity to between 15% and 25%.
- ⇒ Push the button START AHEAD on WECS-9520 manual control panel to start the engine.
- ⇒ Use the rotary knob to adjust the fuel injection quantity, which controls the engine speed. Operate the engine until all cylinders fire regularly.
- ⇒ Push the button STOP to stop the engine.
- ⇒ On the WECS-9520 manual control panel, push the button REMOTE AUTO. CONTROL. The remote control now has control.
- ⇒ You can now use the remote control to start the engine.

Intentionally blank

Control Diagram

Designations (Description to 4003-1, 4003-2 and 4003-3)

1. Part code numbers

- A** Control air supply unit
- B** Fuel supply
- D** Servo oil supply
- E** Valve unit for start
- F** Exhaust valve drive
- H** Instrument panel
- I** Pressure switches and pressure transmitters
- K** Local control panel

1.	Speed setting system		
01	Crank angle sensor unit	21	Fuel pump actuator
04	Speed pick-up	22	Non-return valve
2.	Starting system	24	Fuel inlet pipe
03	Shut-off valve for starting air	28	Piping
04	Non-return valve	29	HP fuel pipe
05	Control valve	39	Plug
06	Drain and test valve	40	Stop valve
07	Starting air valve	41	Injection control valve
08	Flame arrester	42	Fuel quantity piston
09	Relief valve	43	Actuator piston
10	Handwheel for shut-off valve	46	Fuel leakage pipe
13	Blocking valve on turning gear	47	HP pipe to injection valve
21	Venting valve	48	Fuel leakage pipe, pressurized
27	Venting valve	49	Fuel leakage pipe
3.	Fuel system	52	Fuel overpressure safety valve
01	Injection valve	53	Pressure retaining valve
02	Injection control unit	55	Camshaft
03	Fuel quantity sensor	67	Non-return valve
05	Fuel rail	76	Rail valve
06	Fuel pressure control valve	77-1	Pressure transmitter
08	Fuel shut-down pilot valve	77-2	Pressure transmitter
10	Level switch	81-1	Non-return valve
14	Fuel pump	81-2	Non-return valve
15	Fuel booster pump (plant)	81-3	Non-return valve
17	Leakage inspection point		
19	Cut-out device (tool)		

Designations (Description to 4003-1, 4003-2 and 4003-3)

4.	Exhaust valve drive	68	Disc spring
01	Exhaust valve	69	Two-stage piston
02	Air spring	70-1	Stroke sensor
03	Valve drive	71	Stroke measuring device
06	Non-return valve with throttle	76	Rail valve
08	Air spring venting	77-1	Pressure transmitter
10	Exhaust valve control unit	77-2	Pressure transmitter
11	Servo oil rail	80	Stop valve
15	Servo oil pump	88	Servo oil service pump
16	Pressure control valve		
17	Leakage inspection point		
18	Level switch		
20	Automatic filter		
22	Crankcase	7.	Monitoring
23	Safety valve	18	Collector for leakage oil from air spring
24-1	Non-return valve		
24-2	Non-return valve	8.	Cylinder lubricating system
30-5	Stop valve	06	Cylinder lubricating pump
37	Stop valve	09	Lubricating quill with non-return valve
39	Gear wheel crankshaft	11-1	Pressure reducing valve
41	Intermediate wheel supply unit	17	Duplex filter
42	Gear wheel	19	Measurement tube
44	Gear wheel		
45	Pinion	9.	Engine room
50	Carrier with shearable overload protection	01	Starting air bottles
51	Supply pipe	02	Oil pump (low pressure)
53	Non-return valve	03	Oil pump (high pressure)
54	Flow sensor	04	Oil filter
55	HP servo oil pipe	05	Oil cooler
63	Servo oil return piping	06	Non-return valve (on engine)
66	Actuator pipe		

Designations (Description to 4003-1, 4003-2 and 4003-3)

	Sensors		Actuators
PS3121A	Cyl. lube oil filter diff. pressure	CV7231-33C CV7221-22C	Fuel pump actuator No. A1, B1, C1 Servo oil pump actuator No. 1-2
PT2041A	Cyl. lubr. servo oil free end	ZV7201-07A/B ZV7201-07C-H ZV7241-47C ZV7131-37C ZV7061S ZV7013C ZV7014C	Exhaust valve control unit Cyl. 1-7 Injection control unit Cyl. 1-7 Start air pilot valve Cyl. 1-7 Cylinder lubrication valve Cyl. 1-7 EM. STOP (Fuel Shd pilot valve) Common start valve 1 Common start valve 2
PT2046A	Cyl. lubr. servo oil leakage free end		
PT2071C	Servo oil rail pressure		
PT2072C	Servo oil rail pressure		
PT3131-37C	Cyl. lubricating oil		
PT3421A	Fuel upstream of supply unit		
PT3461C	Fuel rail pressure		
PT3462C	Fuel rail pressure		
PT3601-07C	Firing press. Cyl 1-7 optional ICC		
LS2055A	Servo oil supply unit, leak		
LS3426A	Fuel supply unit, leak		
LS3444A	Rail unit general leak		
LS3446A	Injection control unit or pipe for injection valve leak		
FS2061-62A	Servo oil pump 1-2 (flow)		
GT5126C	Crank angle sensor 1		
GT5127C	Crank angle sensor 2		
ZS5016C	Turning gear disengaged		
ZS5018C	Start air shutoff valve man. closed		
ZS5123C	Engine TDC signal		
ZT5421-27C	Exhaust valve 1-7, open and close positions (driving end)		
ZT5461-67C	Fuel injection quantity cylinder 1-7		
			Local indications
		PI2041L	Cylinder lubr. servo oil free end
		PI2051L	Servo oil unit (inlet pressure)
		PI2071M	Servo oil rail pressure
		PI3421L	Fuel pressure supply unit inlet
		PI3431L	Fuel pressure supply unit outlet
		PI3462M	Fuel rail pressure
		FI2076L	Exhaust valve hydraulic oil, HP pipe leakage indication on exhaust valve control unit
		SI5101M	Engine speed

Intentionally blank

Control Diagram

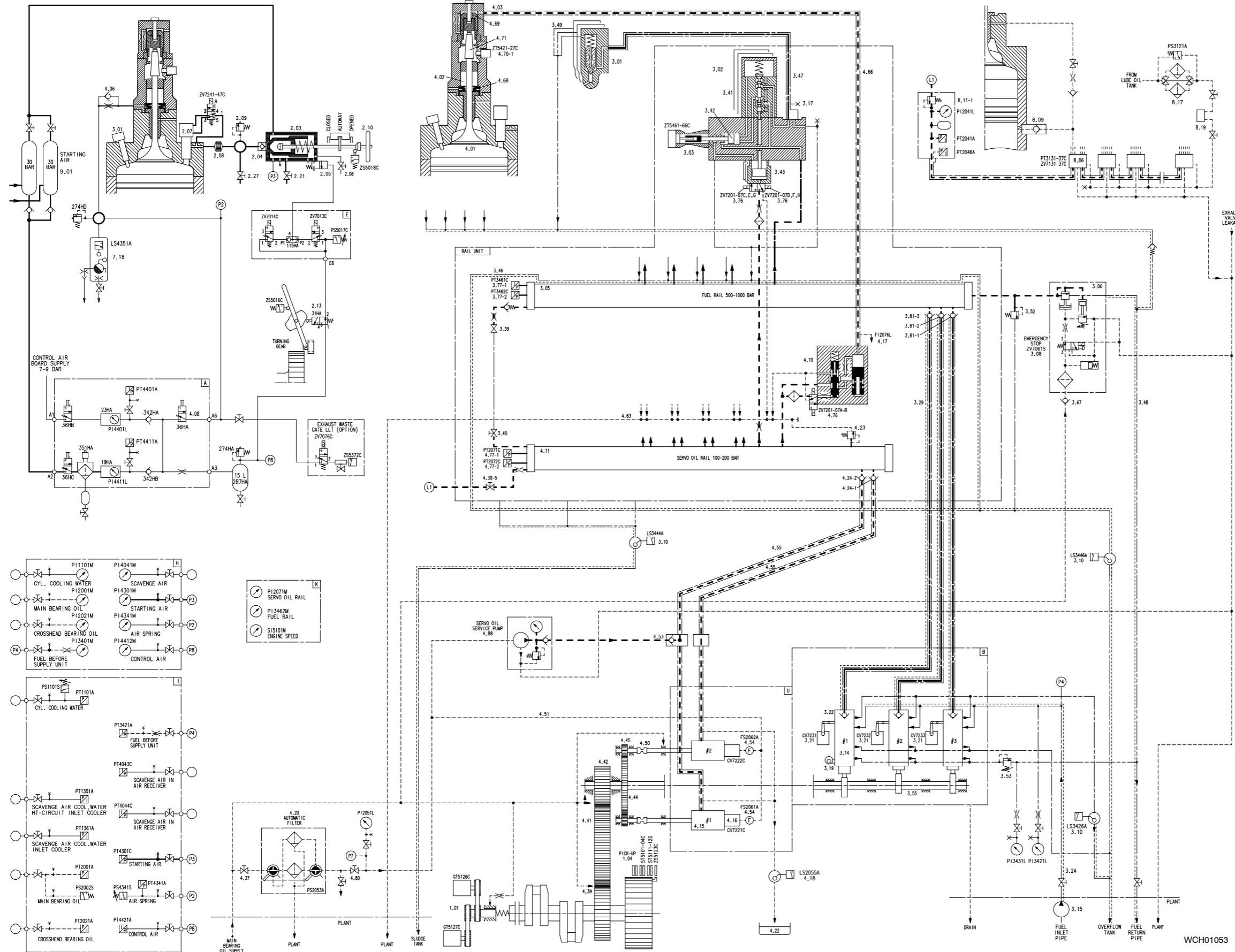

WCH01053

Remark: Systems are drawn for engine in the STOP position with unpressurized circuits.

- LOW PRESSURE OIL CIRCUITS
- HIGH PRESSURE OIL CIRCUITS
- ... LOW PRESSURE FUEL CIRCUITS
- · - · HIGH PRESSURE FUEL CIRCUITS
- HEATING
- CONTROL AIR CIRCUITS
- STARTING AIR CIRCUITS

Intentionally blank

Control and Auxiliary Systems

Detailed Control Diagrams with Interfaces to the Plant

On pages 3 to 15, the full engine control with the auxiliary systems, divided into their various functions, is shown. The data includes all interfaces to the plant and the remote control with clear identification of the internal and external connections.

Overview of the systems	Path No. range	Page
Air supply	30	3
Bearing and cooling oil supply	40	4
Servo oil supply	50	5
Fuel supply	60	6
Starting system	110	7
Speed control	150	8
Cylinder lubrication pulse feed	170	9
Exhaust gas / turbocharger type TPL, A100-L and MET / scavenge air / auxiliary blower (1-stage scavenge air cooler). See Note.	300	10
Exhaust gas / turbocharger type TPL, A100-L and MET / scavenge air / auxiliary blower (2-stage scavenge air cooler). See Note.	300	11
Exhaust valve drive, air spring (pulse lubrication)	310	12
Fuel injection	330	13
Cooling water (cylinder)	340	14
Main bearing & crosshead bearing lubrication, piston cooling, oil mist detector	350	15

Note – Design alternative

The data is continued on page 2.

Detailed Control Diagrams with Interfaces to the Plant

How to read the diagrams:

Each diagram has a Path No. range given to the system part. The Path No. range is divided into 10 sections on the right side of the page. These path numbers give the connections between related diagrams.

In the example below, the control air pipe that has the number 38 (page 3) goes to the target path No. 51 (found on page 5).

Where two path numbers that are the same are shown, letter indications are used. For example, on page 3, there are the numbers 38 and 38A. The number 38 is Control Air and the number 38A is Air Spring Air.

Example:

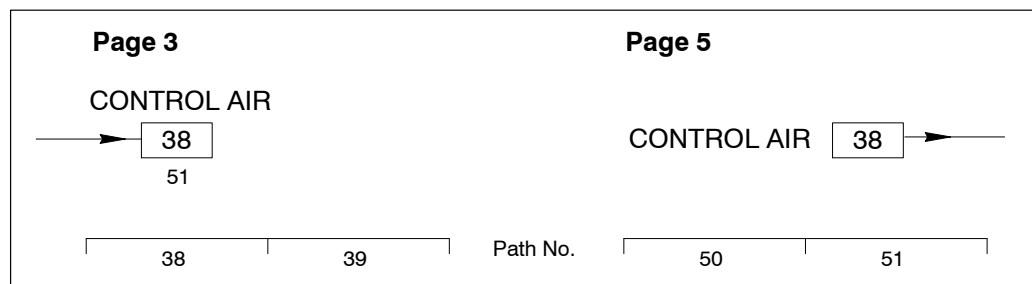

The interfaces to the remote control, local alarm and instruments have symbols (see the example below).

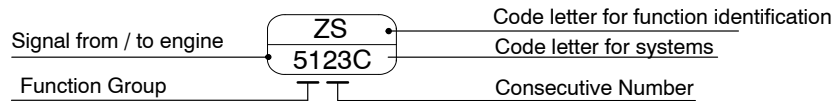

Remark: Systems are drawn for engine in the STOP position with unpressurized circuits.

- Low pressure oil circuits
- - - - - High pressure oil circuits
- Low pressure fuel circuits
- · - · - High pressure fuel circuits
- Heating
- Control air circuits
- Starting air circuits

Air Supply

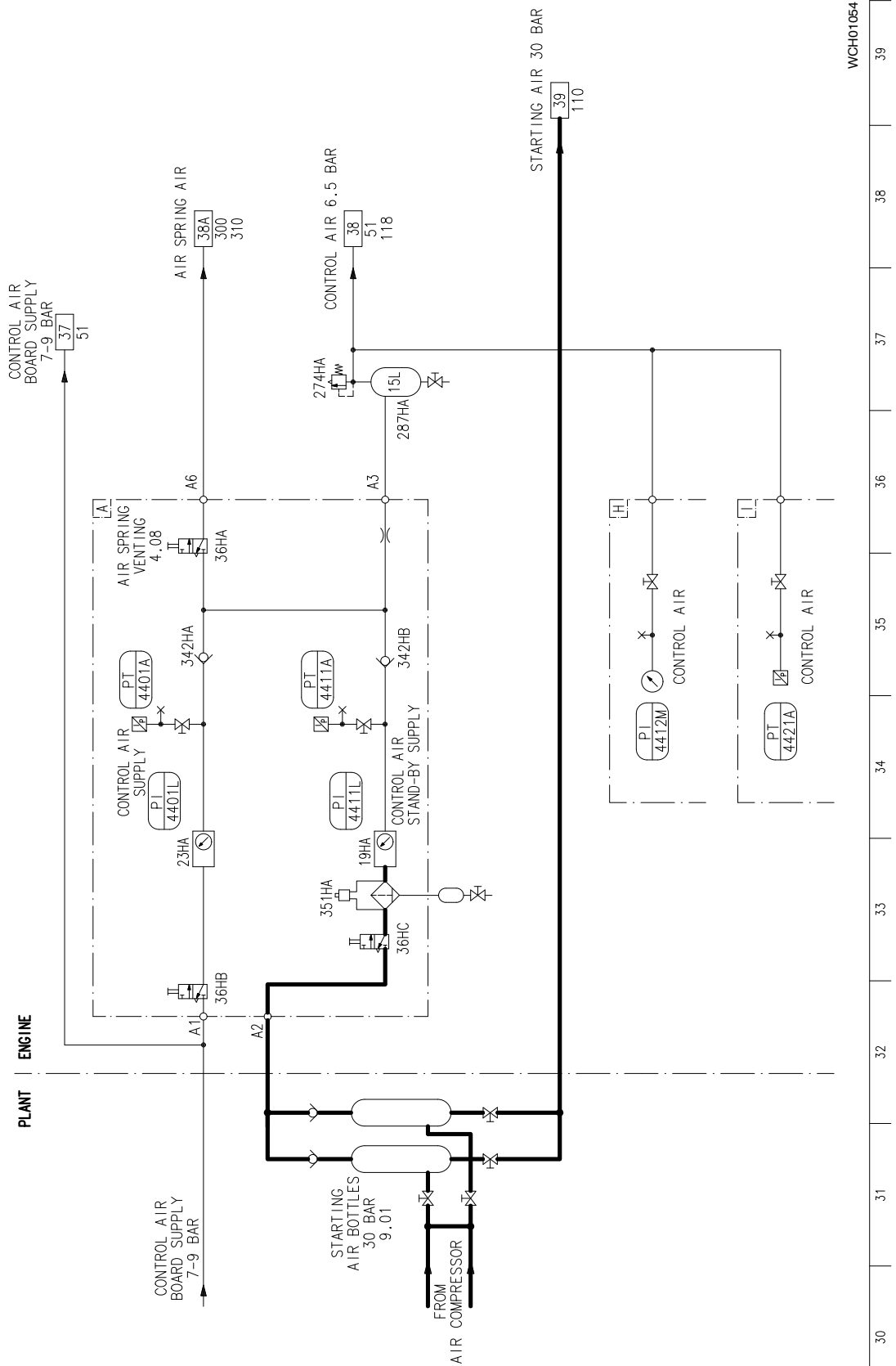

WCH01054



Bearing and Cooling Oil Supply

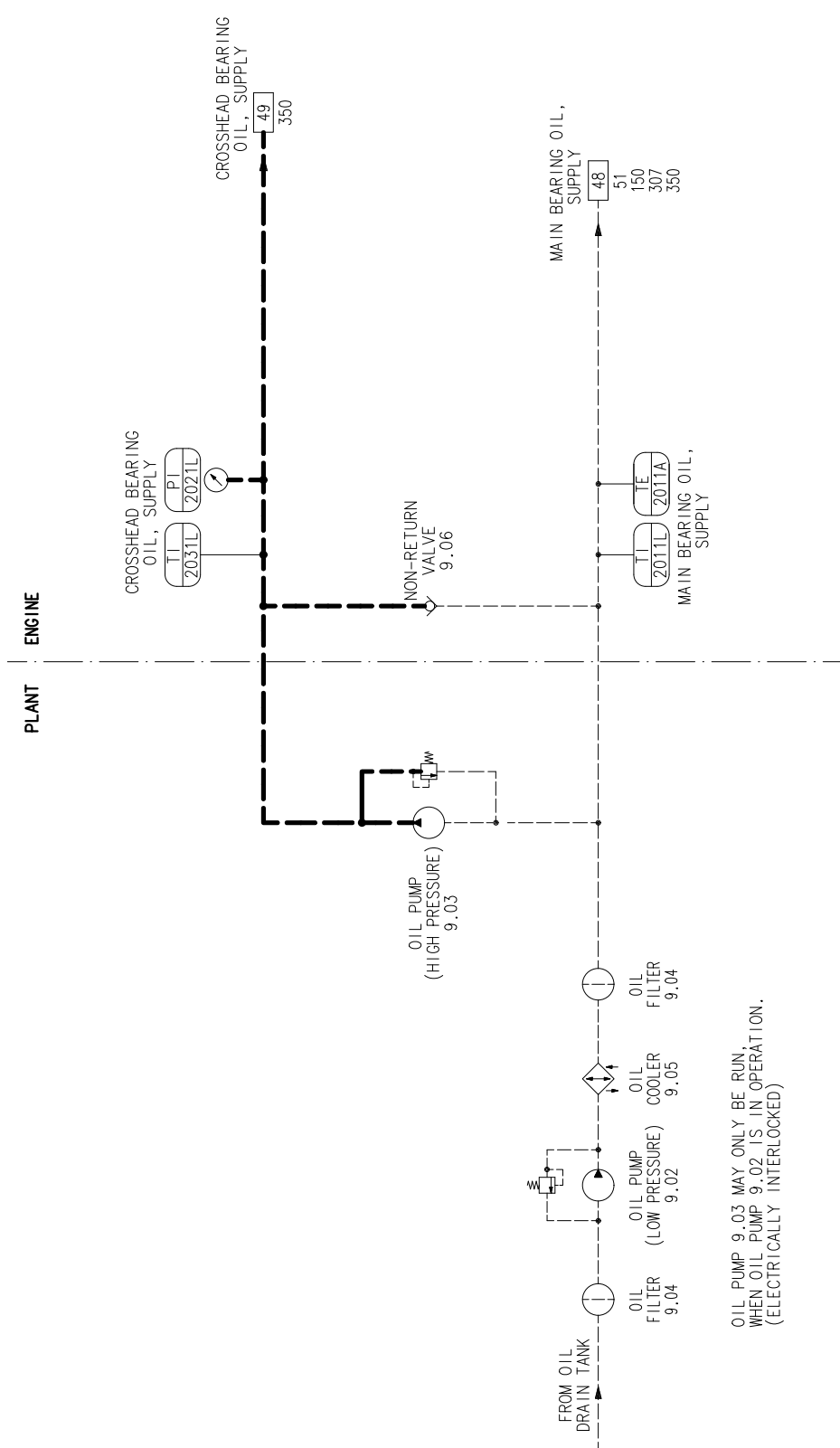

OIL PUMP 9.03 MAY ONLY BE RUN WHEN OIL PUMP 9.02 IS IN OPERATION. (ELECTRICALLY INTERLOCKED)

WCH01054

40	41	42	43	44	45	46	47	48	49
----	----	----	----	----	----	----	----	----	----

Servo Oil Supply

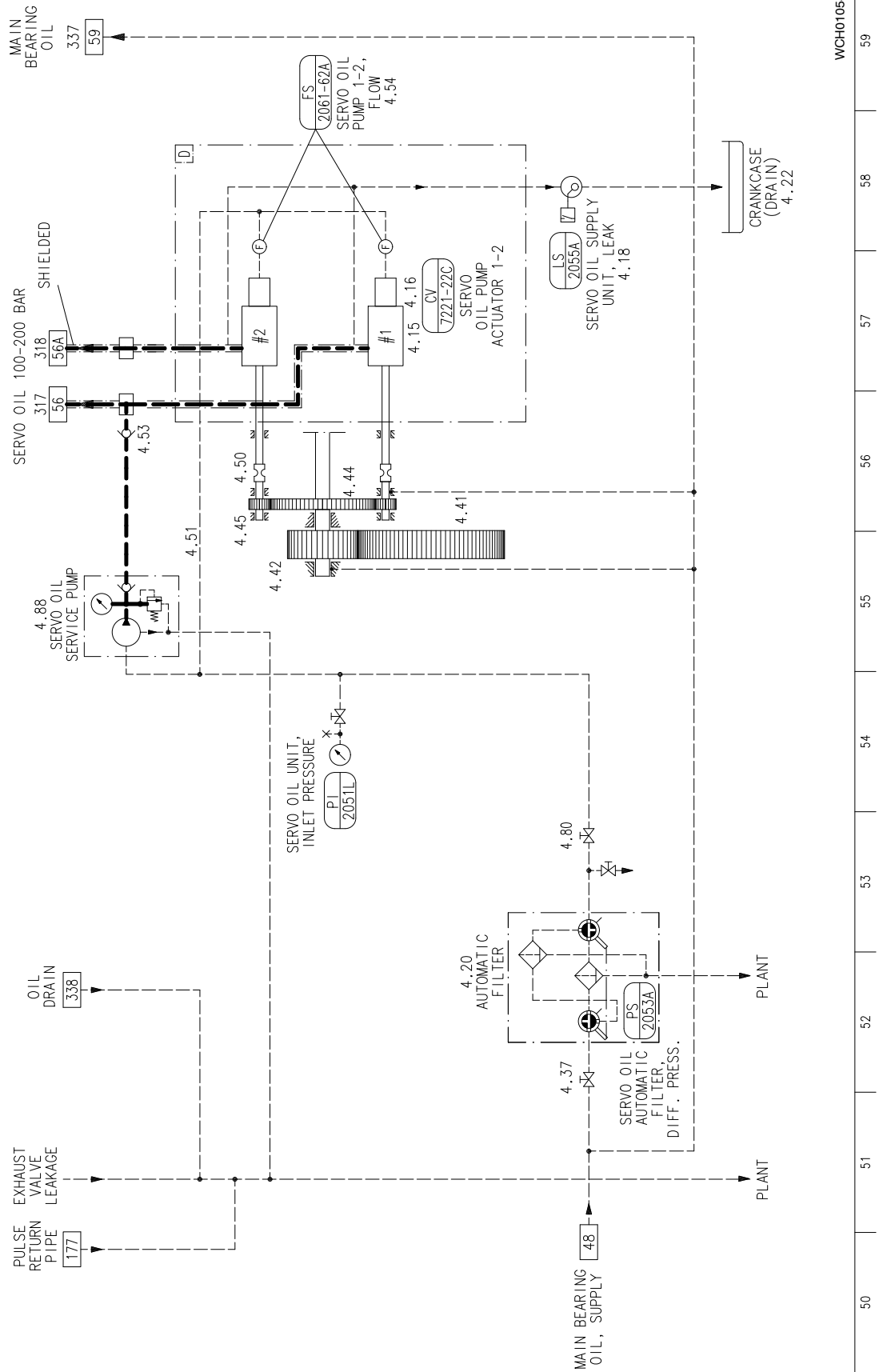

WCH01054

50 51 52 53 54 55 56 57 58 59

Fuel Supply

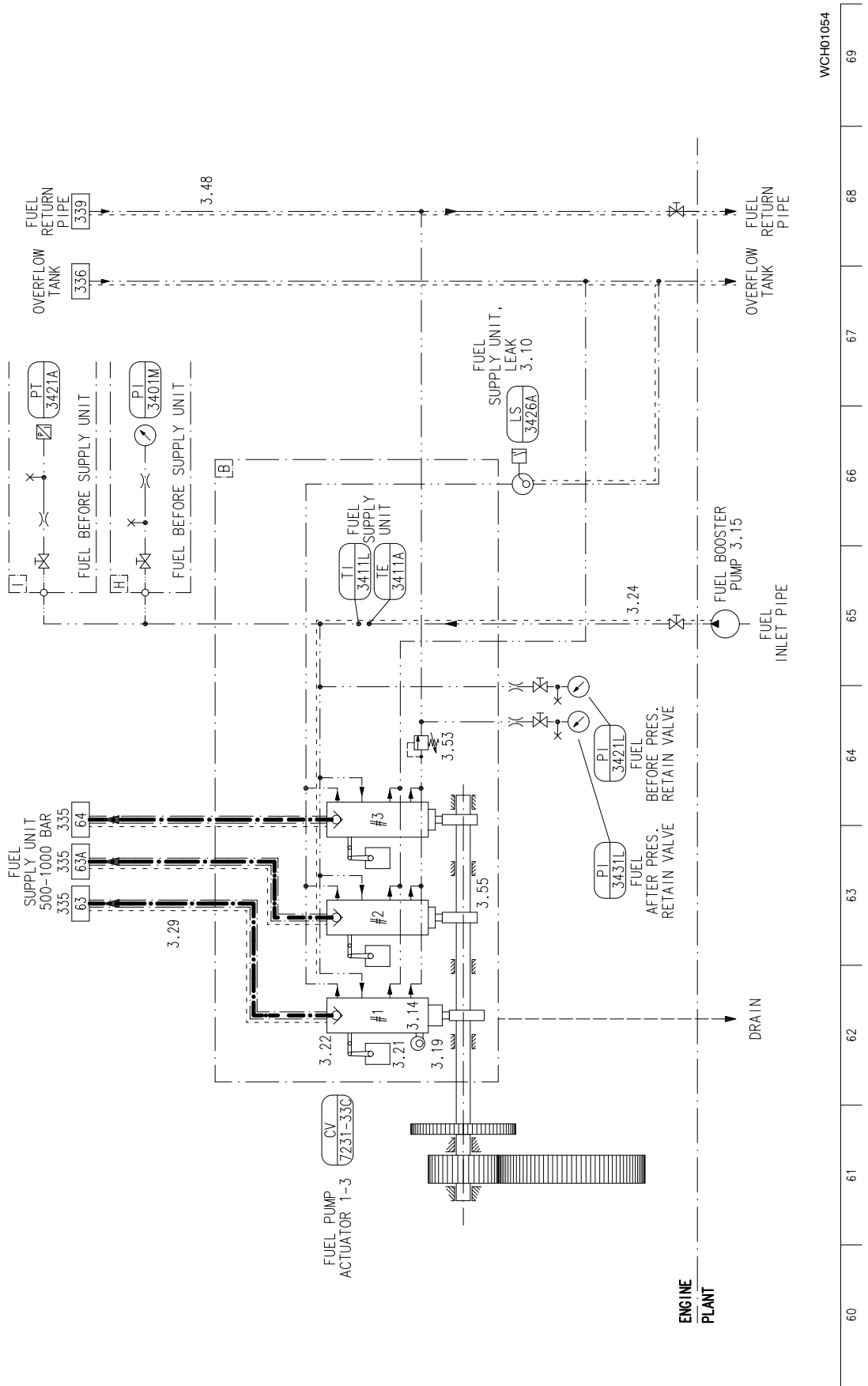

Starting System

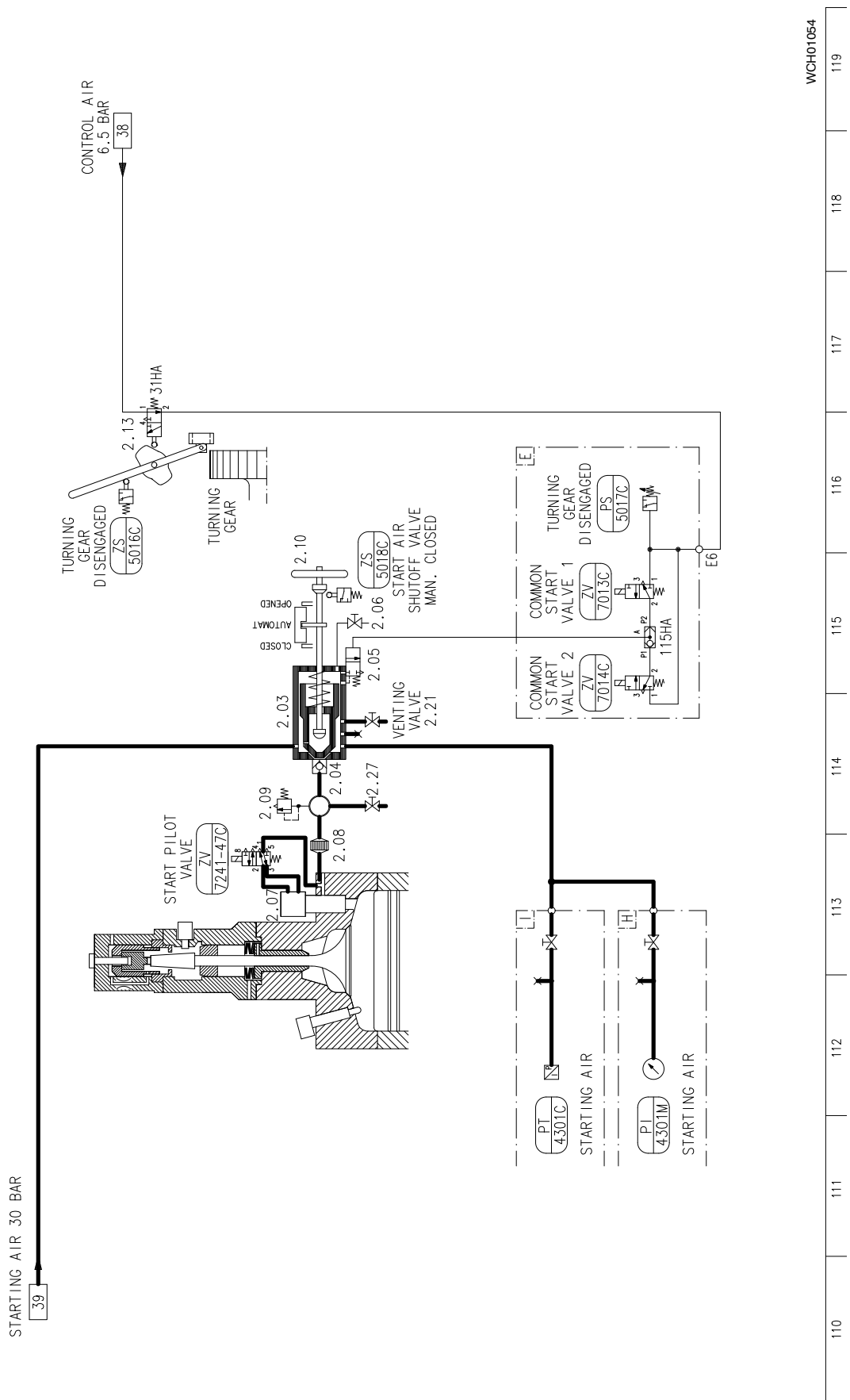

Speed Control

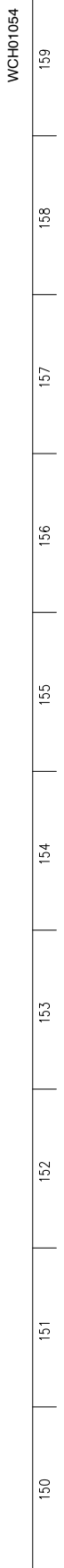
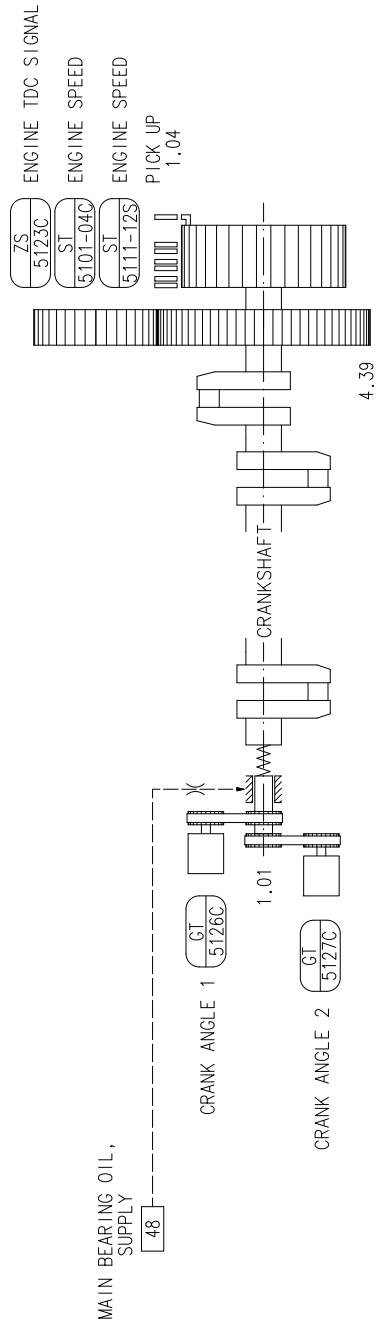

Cylinder Lubrication Pulse Jet

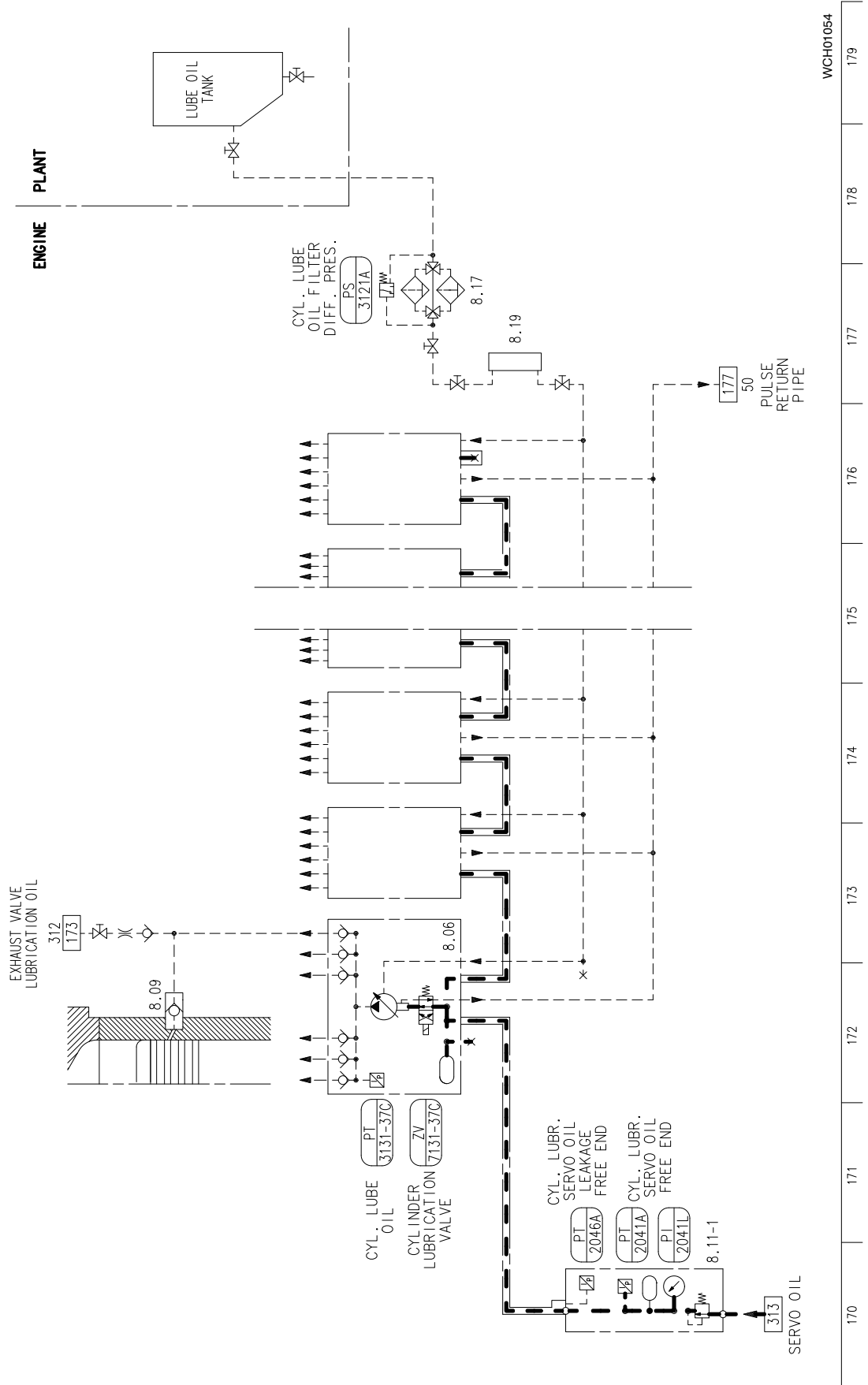

WCH01054

170 171 172 173 174 175 176 177 178 179

Exhaust Gas / Turbocharger Type TPL, A100-L and MET / Scavenge Air / Auxiliary Blower

for 1-Stage Scavenge Air Cooler

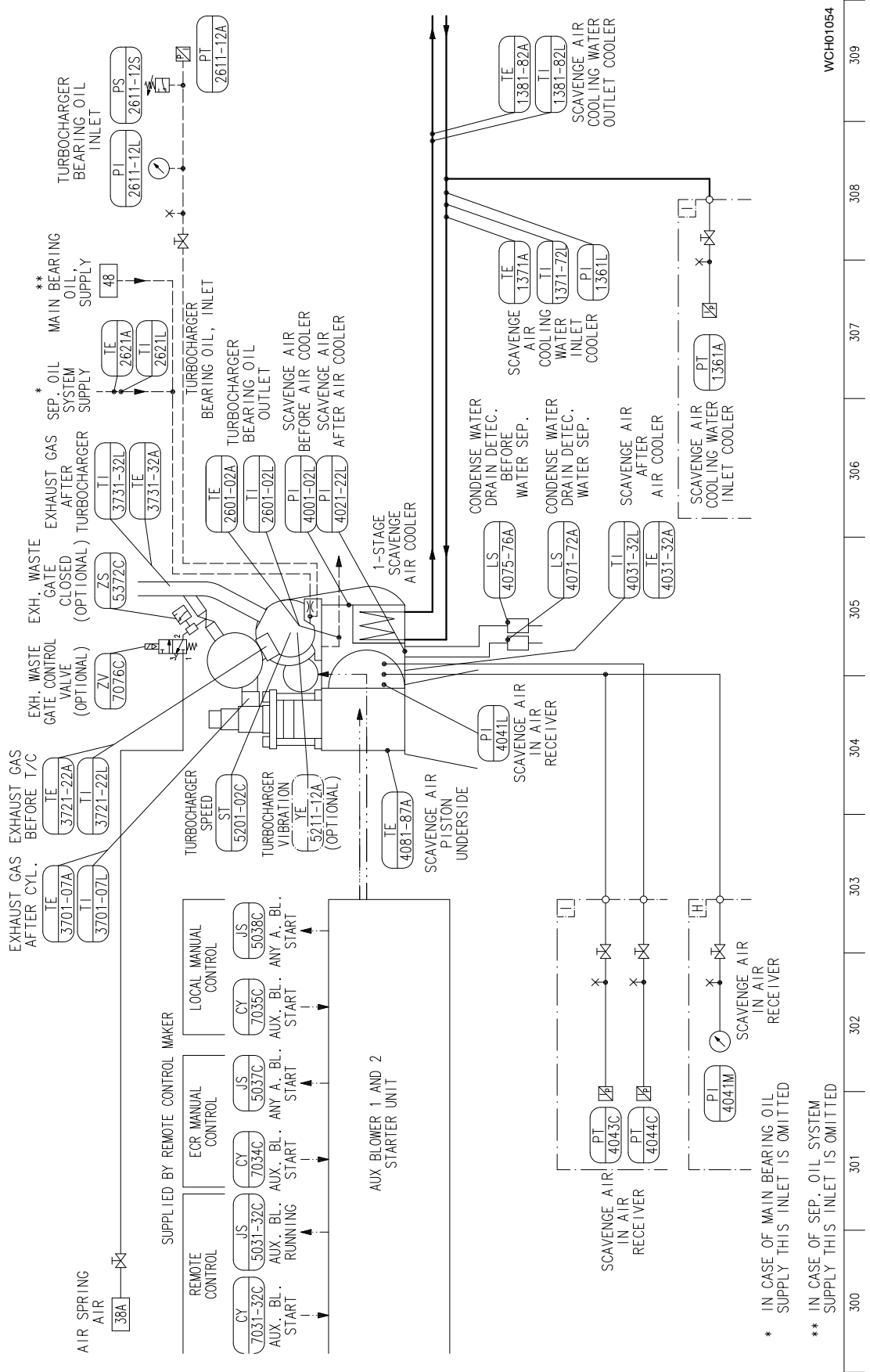

* IN CASE OF MAIN BEARING OIL SUPPLY THIS INLET IS OMITTED
 ** IN CASE OF SEP. OIL SYSTEM SUPPLY THIS INLET IS OMITTED

WCH01054

Exhaust Gas / Turbocharger Type TPL, A100-L and MET / Scavenge Air / Auxiliary Blower
for 2-Stage Scavenge Air Cooler

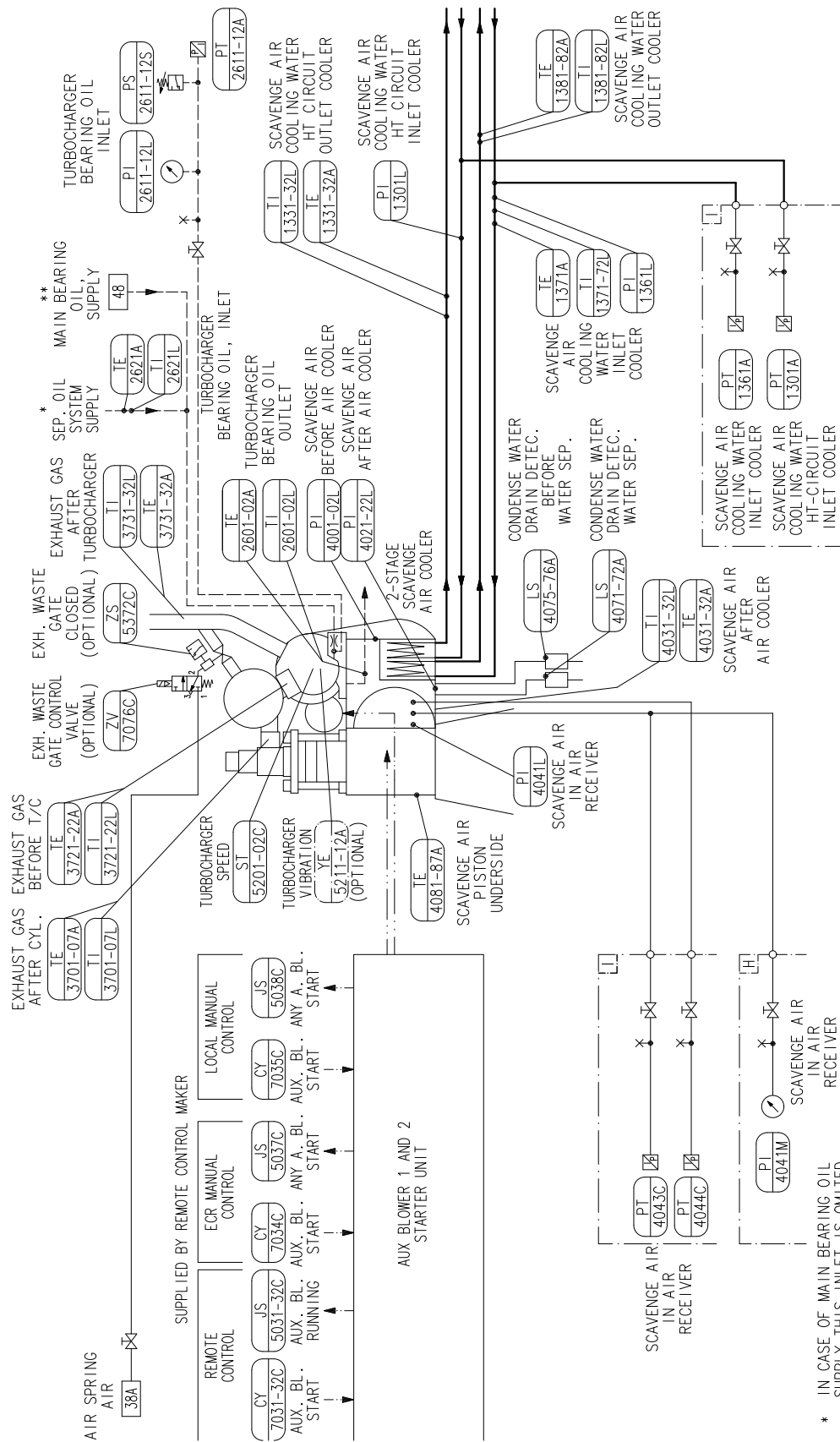

* IN CASE OF MAIN BEARING OIL SUPPLY THIS INLET IS OMITTED
** IN CASE OF SEP. OIL SYSTEM SUPPLY THIS INLET IS OMITTED

WCH01054

300 301 302 303 304 305 306 307 308 309

Exhaust Valve Drive / Air Spring

Pulse Lubr.

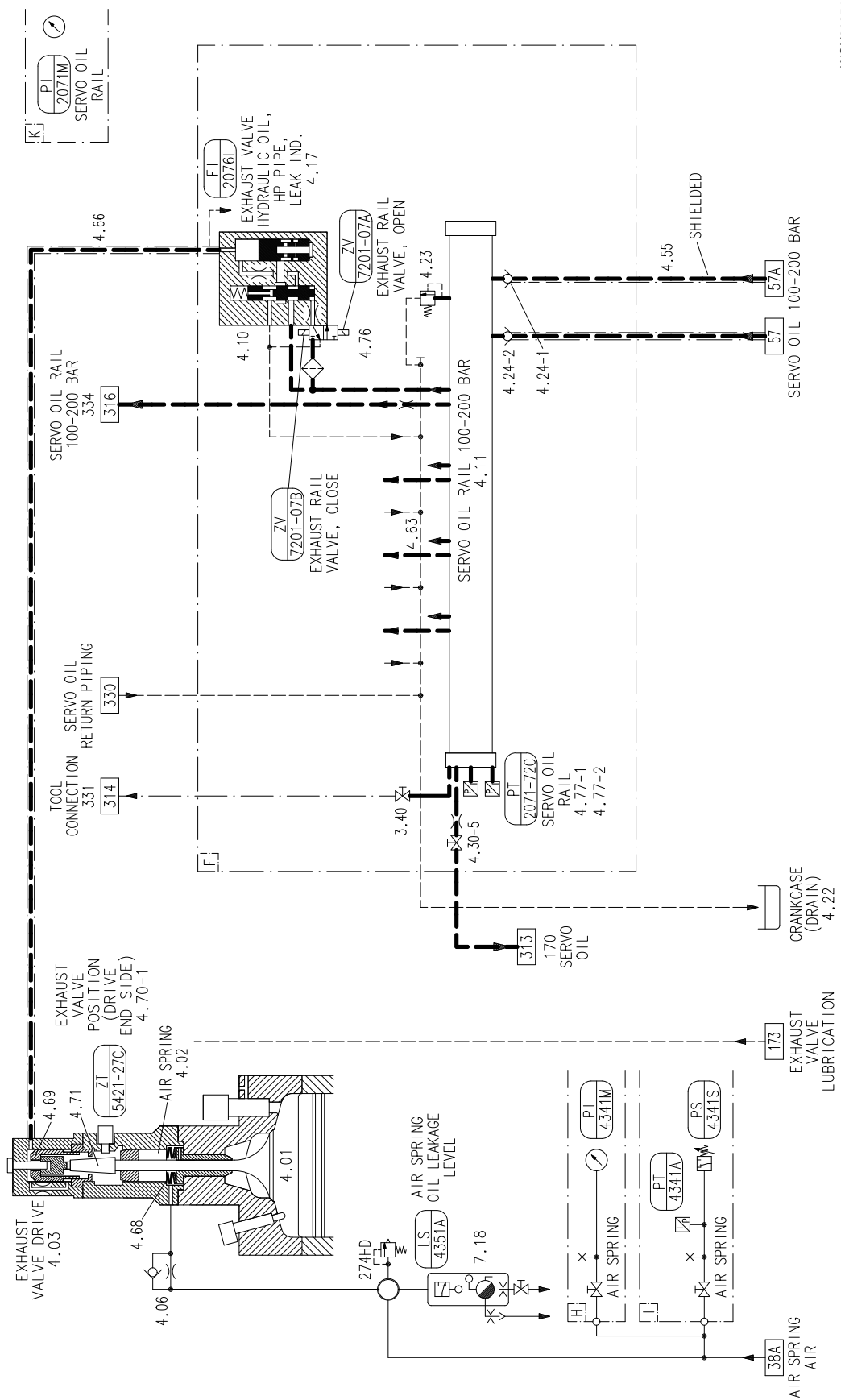

WCH01054

Fuel Injection

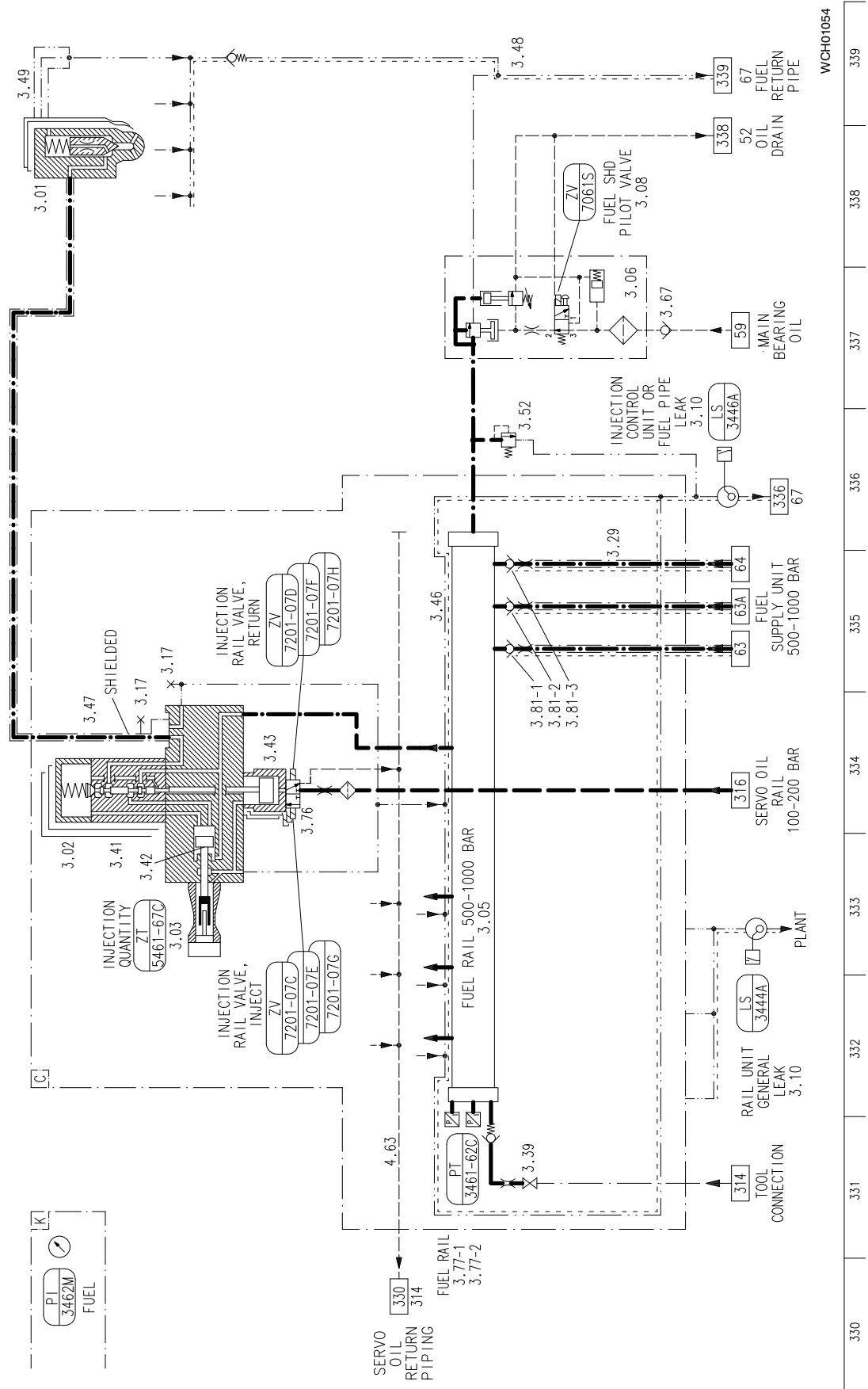

330 331 332 333 334 335 336 337 338 339

WCH101054

Cooling Water (Cylinder)

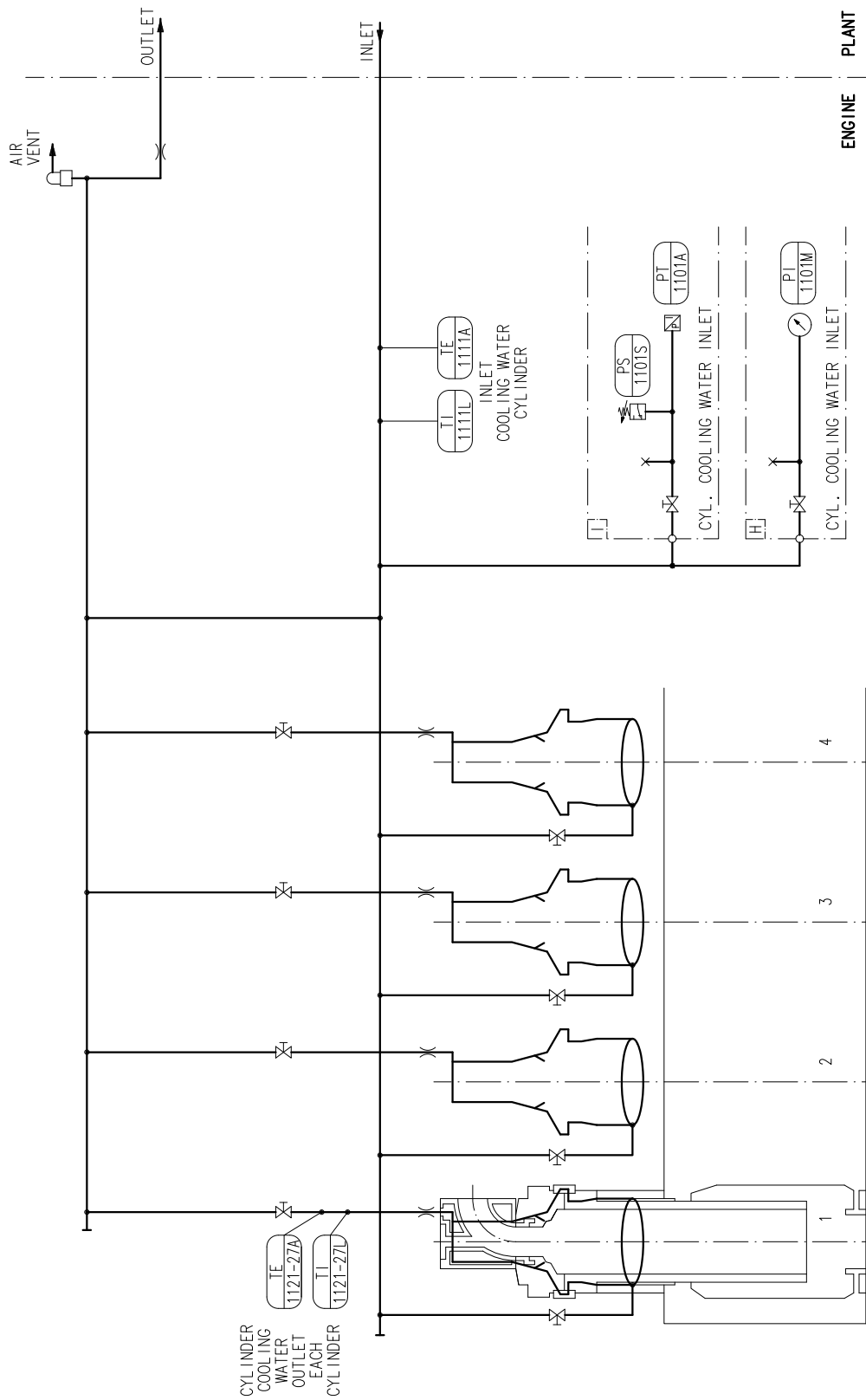

340 341 342 343 344 345 346 347 348 349
WCH01054

Main Bearing & Crosshead Bearing Lubrication / Piston Cooling / OMD

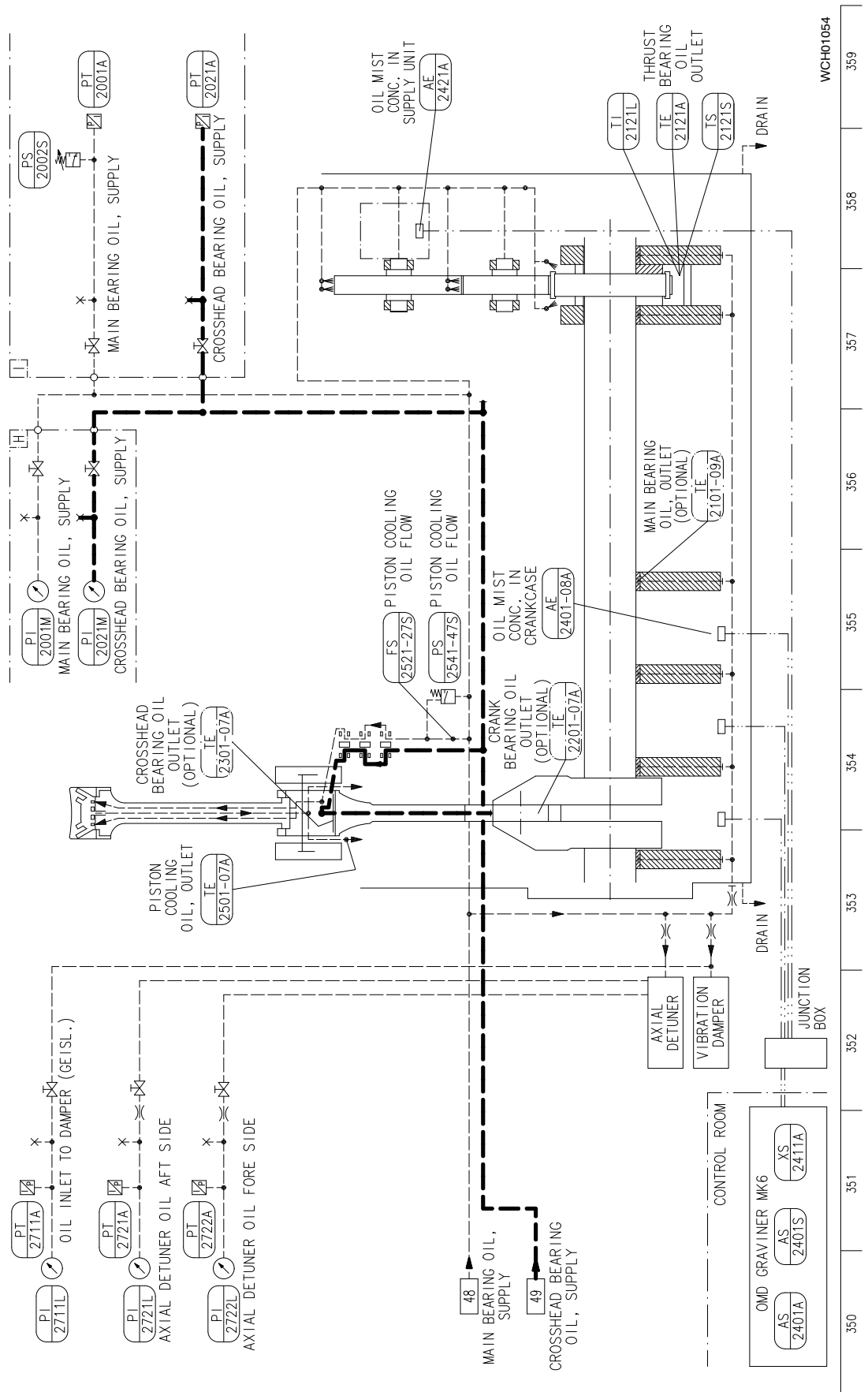

Intentionally blank

Drive Supply Unit

1. General

The drive of the supply unit 6 is installed at the driving end of the engine. The gear wheel 1 moves the intermediate wheel 2, which moves the camshaft of the supply unit. The camshaft turns in the same direction as the crankshaft (see also Supply Unit 5552-1).

The condition of the tooth profile must have regular checks. New gear wheels must have frequent checks after a short running-in period (see the Maintenance Manual 4103-1).

If unusual noises are heard from the area of the gear train, the cause must be found immediately.

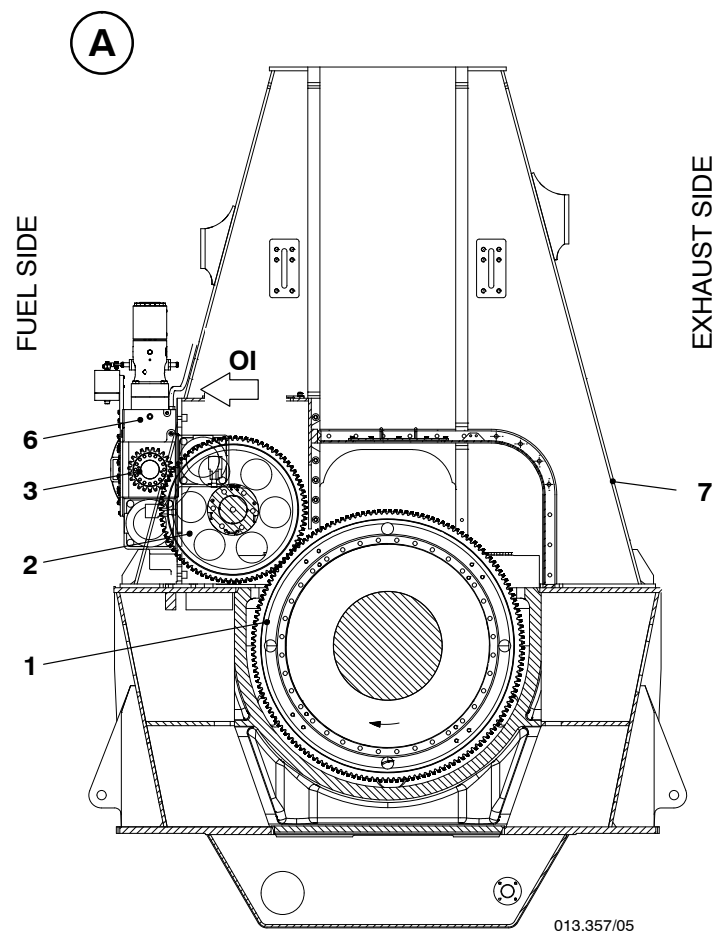

Key to Illustration: 'A' Cross section

- | | |
|----------------------------------|---------------|
| 1 Gear wheel (on the crankshaft) | 6 Supply unit |
| 2 Intermediate wheel | 7 Column |
| 3 Gear wheel for supply unit | OI Oil inlet |

Drive Supply Unit

2. Lubrication

The bearing 4 of the intermediate wheel 2 and the bearings for the camshaft are lubricated with bearing oil through the oil inlet 'OI'. The gear teeth are supplied with bearing oil through the spray nozzles (for more data, see 8016-1 Fig. 'A').

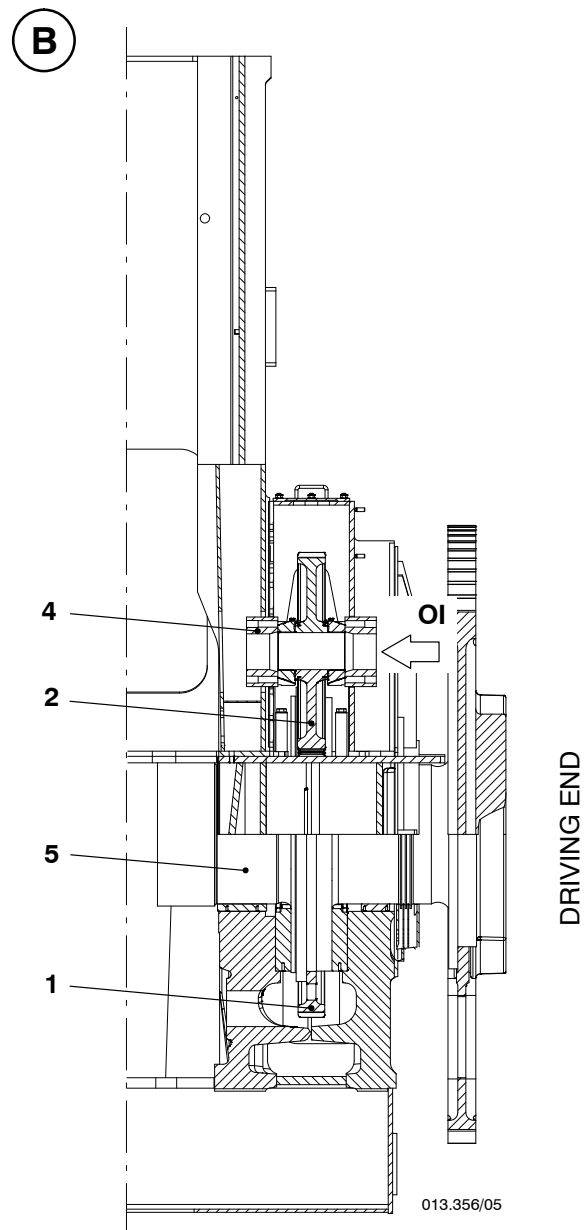

Key to Illustration: 'B' Longitudinal section

- | | |
|----------------------------------|----------------------------------|
| 1 Gear wheel (on the crankshaft) | 4 Bearing for intermediate wheel |
| 2 Intermediate wheel | 5 Crankshaft |
| | OI Oil inlet |

Shut-off Valve for Starting Air

1. General

For more data, see the Control Diagram in [4003-2](#).

The starting air shut-off valve (shut-off valve), see Fig. A stops or releases the starting air into the engine. You use the handwheel 2 to put the shut-off valve in the positions that follow:

- CLOSED (closed manually)
- AUTOMAT
- OPENED (opened manually).

When the engine is in stand-by mode or during operation, the lever 1 holds the shut-off valve in the AUTOMAT position.

To do a test of the shut-off valve, do as follows:

- ⇒ Operate the valve 2.06 to make sure the valve 11 opens. When the shut-off valve is ready to open, the valve 11 opens, which you can clearly hear, however the engine will not start.



Remark: When the engine is not in operation, do the procedure that follows:

- ⇒ Close the shut-off valves of the starting air bottles 9.01.
- ⇒ Lift the lever 1, then use the handwheel 2 to close the shut-off valve to the CLOSED position.
- ⇒ Open the venting valve 2.21 to release the air in the the shut-off valve and the air feed pipes.
- ⇒ Open the venting valve 2.27 to release the air in the the starting air distribution pipe.
- ⇒ Engage the turning gear.

After each maneuvering period, open the venting valve 2.27 in the starting air distributor pipe to drain the condensate water (see also the Starting Air Diagram [8018-1](#)).

2. Function

Ready to start:

Starting air flows through the air inlet pipe 'AP' into the air inlet chamber 'AI', then through the balance bore 'BB' into the space 'VS'. The spring 10 and the pressure in the space 'VS' keep the valve 11 closed.

Start:

The related FCM-20 module operates the common start valve 6 or 8 (see also [4002-1](#), paragraph 3 Engine-related control functions).

The control air 'CA' opens the control valve 3 through the common start valve 8 and releases the pressure in the space 'VS'. The valve 11 opens and starting air from the air inlet chamber 'AI' flows through the valve body 12 into the starting air supply pipe 'SA'.

End of start:

When the control valve 3 closes, starting air flows through the balance bores 'BB' and fills the the space 'VS' again. The valve 11 closes.

Function check:

When the control valve operates on the ready to start engine, the pressure in the space 'VS' is released. You can hear the valve 11 as it opens.

Shut-off Valve for Starting Air

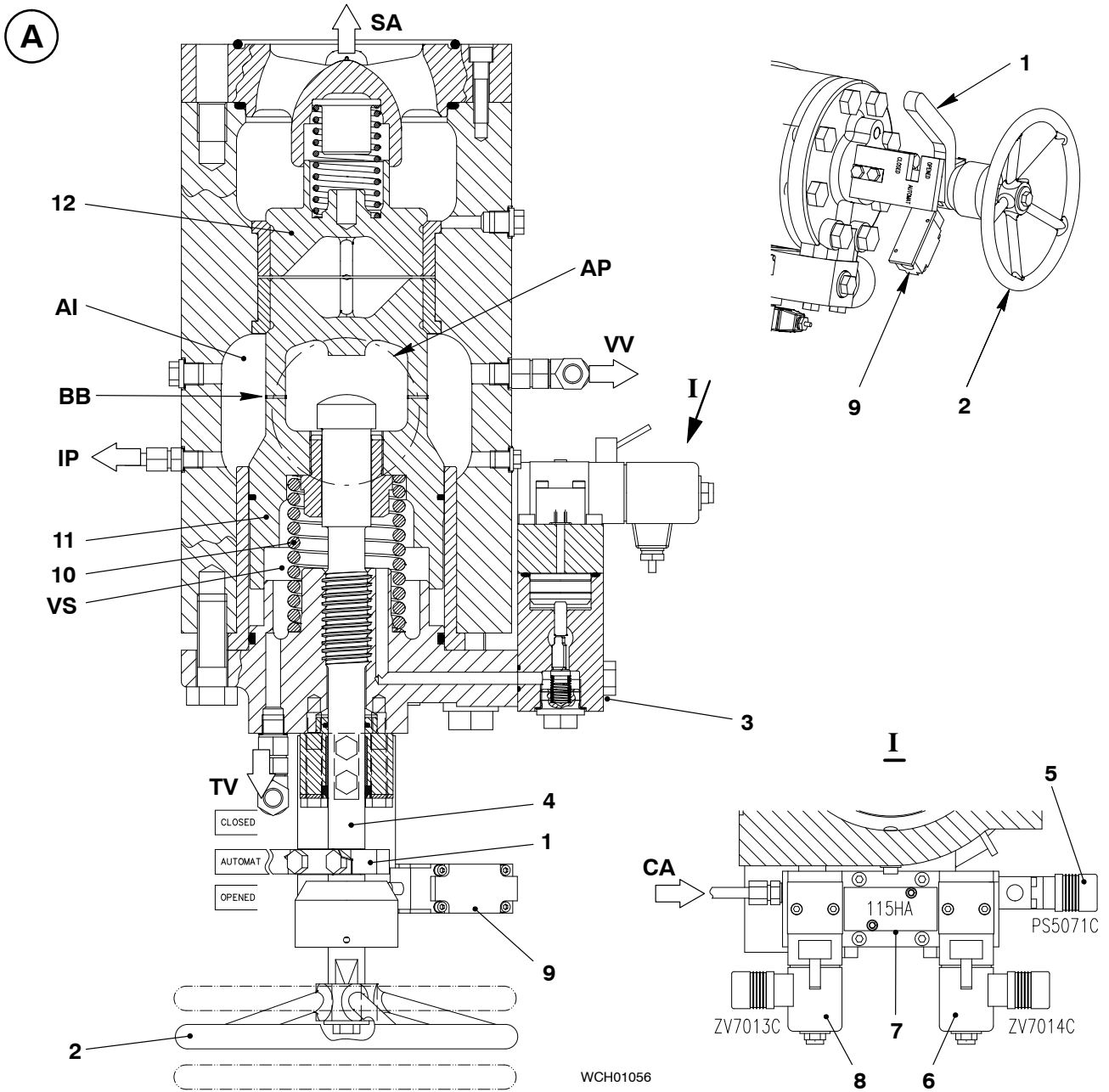

WCH01056

Key to Illustration:

- | | |
|----------------------------------|---------------------------------------------------------------|
| 1 Lever | AI Air inlet chamber |
| 2 Handwheel | AP Air inlet pipe (drawn-in hidden) |
| 3 Control valve 2.05 | BB Balance bore |
| 4 Spindle | CA Control air |
| 5 Pressure switch PS5071C | IP To instrument panel and pressure transmitter PT4301C |
| 6 Common start valve ZV7014C | SA To starting air distribution pipe and starting valves 2.07 |
| 7 Duplex non-return valve 115HA | TV To test valve 2.06 |
| 8 Common start valve ZV7013C | VS Valve space |
| 9 Limit switch ZS5018C | VV To venting valve 2.21 |
| 10 Spring | |
| 11 Valve | |
| 12 Valve body (non-return valve) | |

Control Air Supply

1. General

The compressed air necessary for the air spring air (exhaust valves), the turning gear interlock and the fuel shut-down pilot valve 3.08 comes from the control air board supply. The air must be clean and dry to prevent blockages in the control units.

If the control air board supply system becomes defective, a decreased quantity of compressed air will come from the starting air system.

The shut-off valves, pressure reducing valve, filters etc. that are necessary to supply air to the different units are shown in the control air supply unit **A** and Fig. 'C'.

The numeric titles used to identify the parts of the equipment in the illustrations are the same as those in the Control Diagram 4003-2.

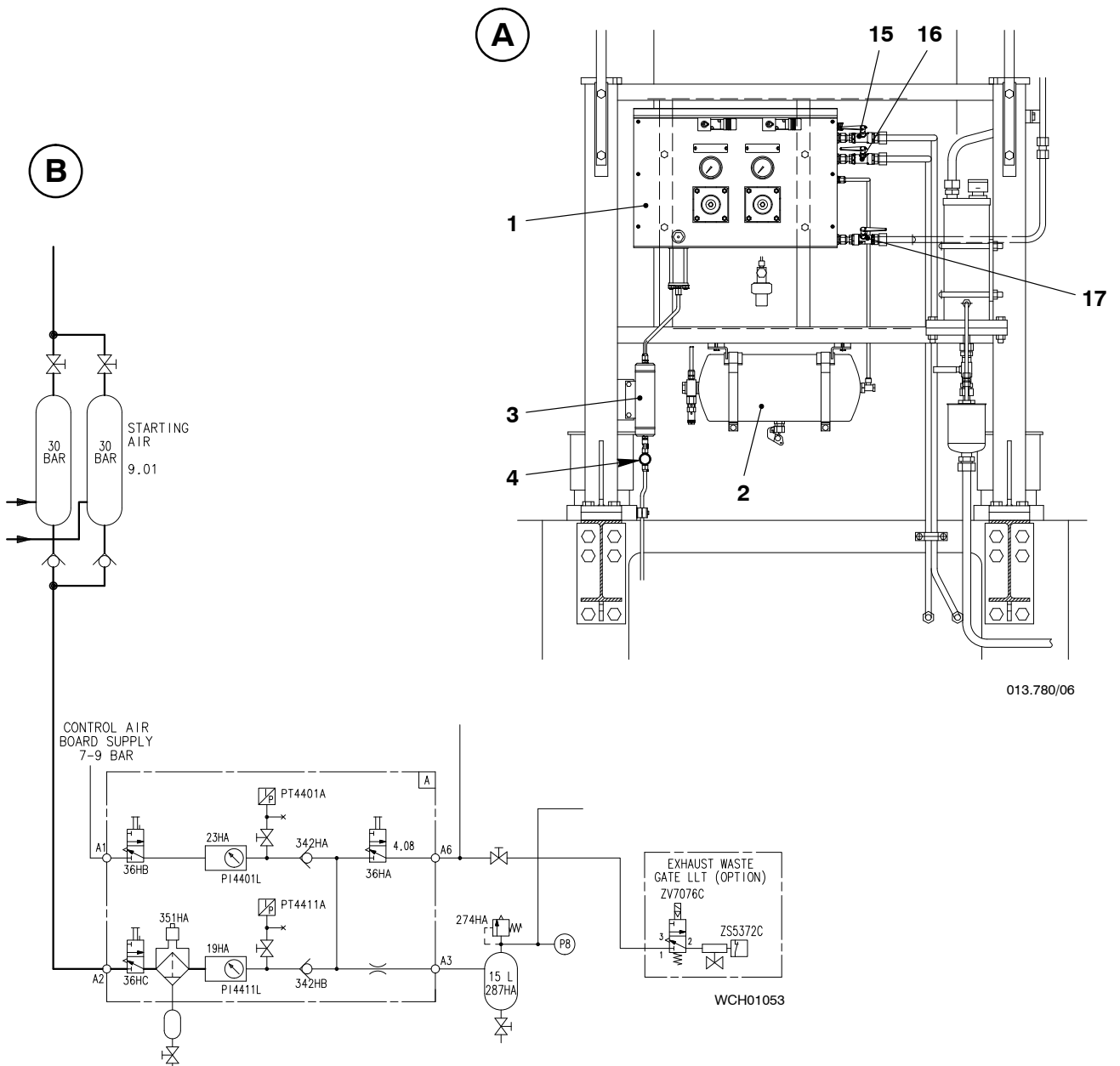

Control Air Supply

C

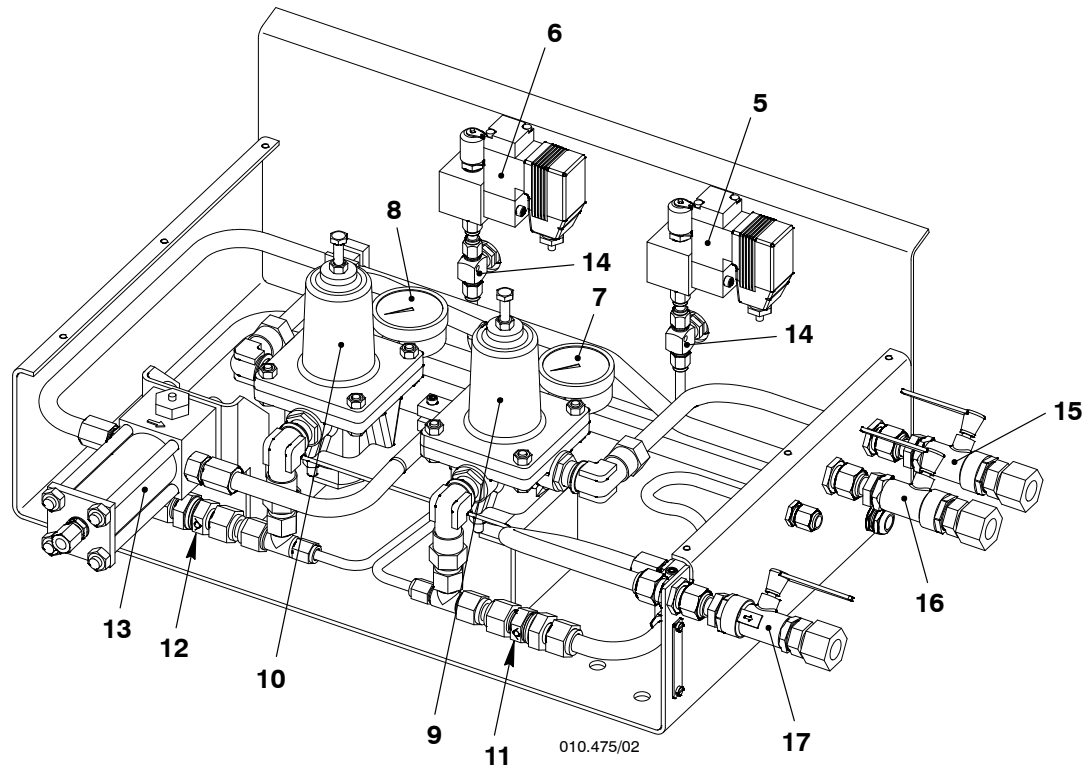

Key to Illustrations: 'A' Location of control air supply
 'B' Diagram of control air supply unit **A**
 'C' Control air supply unit **A**

- | | |
|------------------------------------|---------------------------------------------------------|
| 1 Control air supply unit A | 14 Control valve |
| 2 Air bottle 287HA | 15 Shut-off and venting cock 36HB for control air |
| 3 Condensate water container | 16 Shut-off and venting cock 36HC for starting air |
| 4 Condensate water drain valve | 17 Shut-off and venting cock 36HA (4.08) for air spring |
| 5 Pressure transmitter PT4401A | A1 Control air from board system |
| 6 Pressure transmitter PT4411A | A2 Starting air from starting air bottles 9.01 |
| 7 Pressure gauge PI4401L | A3 Connection to air bottle 287HA |
| 8 Pressure gauge PI4411L | A6 Air spring air supply |
| 9 Pressure reducing valve 23HA | |
| 10 Pressure reducing valve 19HA | |
| 11 Non-return valve 342HA | |
| 12 Non-return valve 342HB | |
| 13 Filter 351HA | |

Local Control Panel

1. General

The local control panel is attached to the engine at the free end and has the components necessary for engine operation (see Fig. 'A'). Because the remote control manufacturer supplies the local control panel, some components can look different from those shown in Fig 'B'.

Some instructions for manoeuvring from the local control panel are given on the nameplate for LOCAL MANUAL CONTROL (for more data, see [4003-1](#) 'Engine local control' and Maneuvering [0260-1](#)).

The WECS-9520 supplies electrical power to the manual control panels, which operate independently from the remote control system. The data shown on the manual control panels is always the same.

There are two manual control panels. One manual control panel is installed in the local control panel 1 (see Fig. 'A'). The other manual control panel is installed in a console in the engine control room (ECR).



Remark: You can only use the function buttons on the manual control panel that has control.

2. Installed components

The local control panel has the components that follow:

- Rotary knob
- ME tachometer
- Emergency stop button
- Telegraph
- WECS-9520 manual control panel (for data, see paragraph 2.2).

Rotary knob:

You use the rotary knob to adjust the speed / fuel settings.

ME tachometer:

The ME tachometer shows the engine speed in the ahead or astern directions.

Emergency stop button:

When you operate the emergency stop button, the engine stops immediately. The fuel shutdown pilot valve 3.08 releases the pressure in the fuel rail. At the same time, the fuel pump supply decreases to 0 (zero).

Telegraph:

The telegraph system is part of the propulsion control system.

2.1 Remote control

The remote control has the components that follow:

- Rotary knob for speed setting or fuel injection quantity adjustments
- Emergency stop
- Telegraph.

Local Control Panel

A

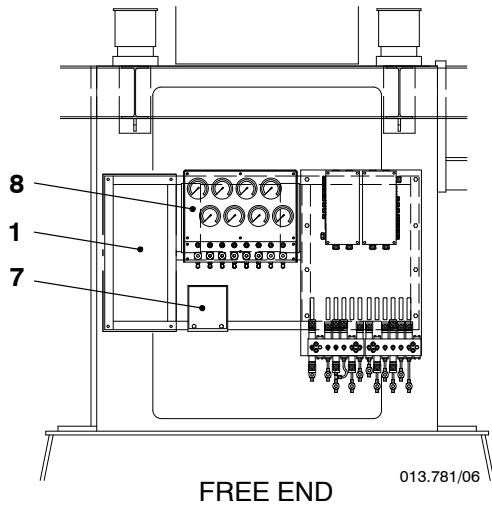

B

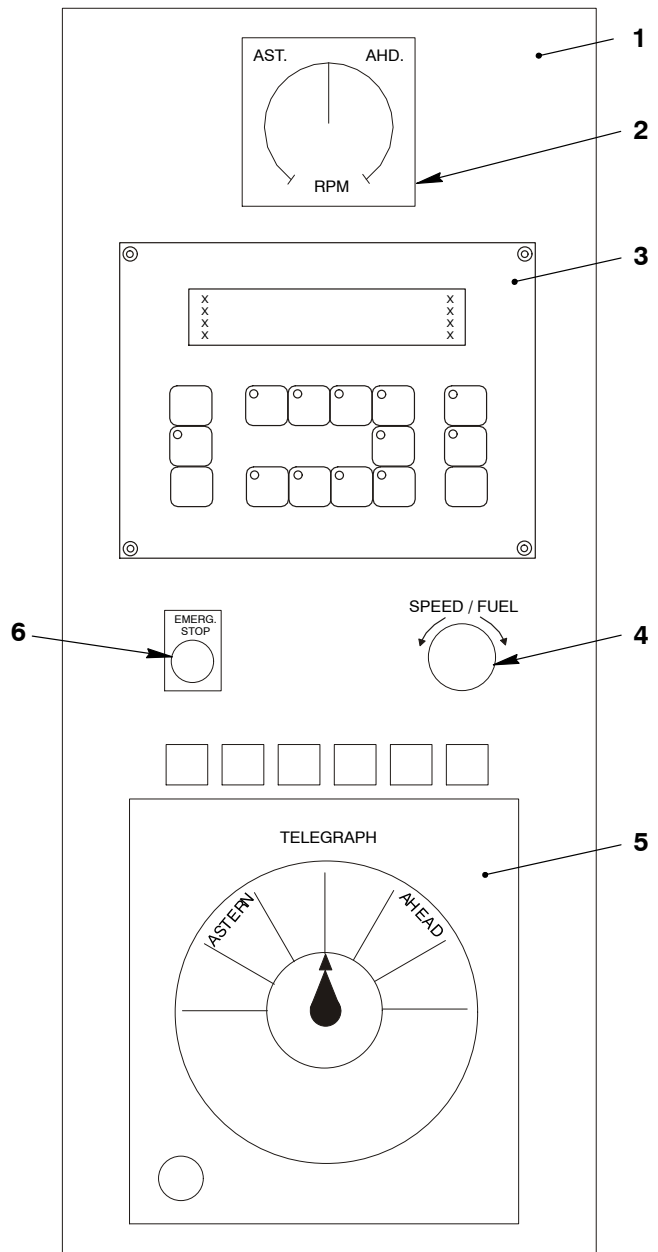

Key to Illustrations:

- | | |
|----------------------------------------------------------------------------------------------------------------------------------------------------------------------------------|-----------------------------------------------------------------------------------------------------------------------------------------------------------------------------------------------------------------------------------------------------------------------|
| <ul style="list-style-type: none"> 1 Local control panel 2 ME tachometer 3 WECS-9520 manual control panel 4 Rotary knob (speed / fuel) | <ul style="list-style-type: none"> 'A' Local control panel – location 'B' Local control panel – front view (example) 5 Telegraph 6 Emergency stop button 7 Nameplate with instructions 8 Instrument panel |
|----------------------------------------------------------------------------------------------------------------------------------------------------------------------------------|-----------------------------------------------------------------------------------------------------------------------------------------------------------------------------------------------------------------------------------------------------------------------|

Local Control Panel

2.2 WECS-9520 manual control panel

The WECS-9520 manual control panel is a multi-purpose module that has an LCD display 1 and 15 function buttons 3 (see Fig. 'C').

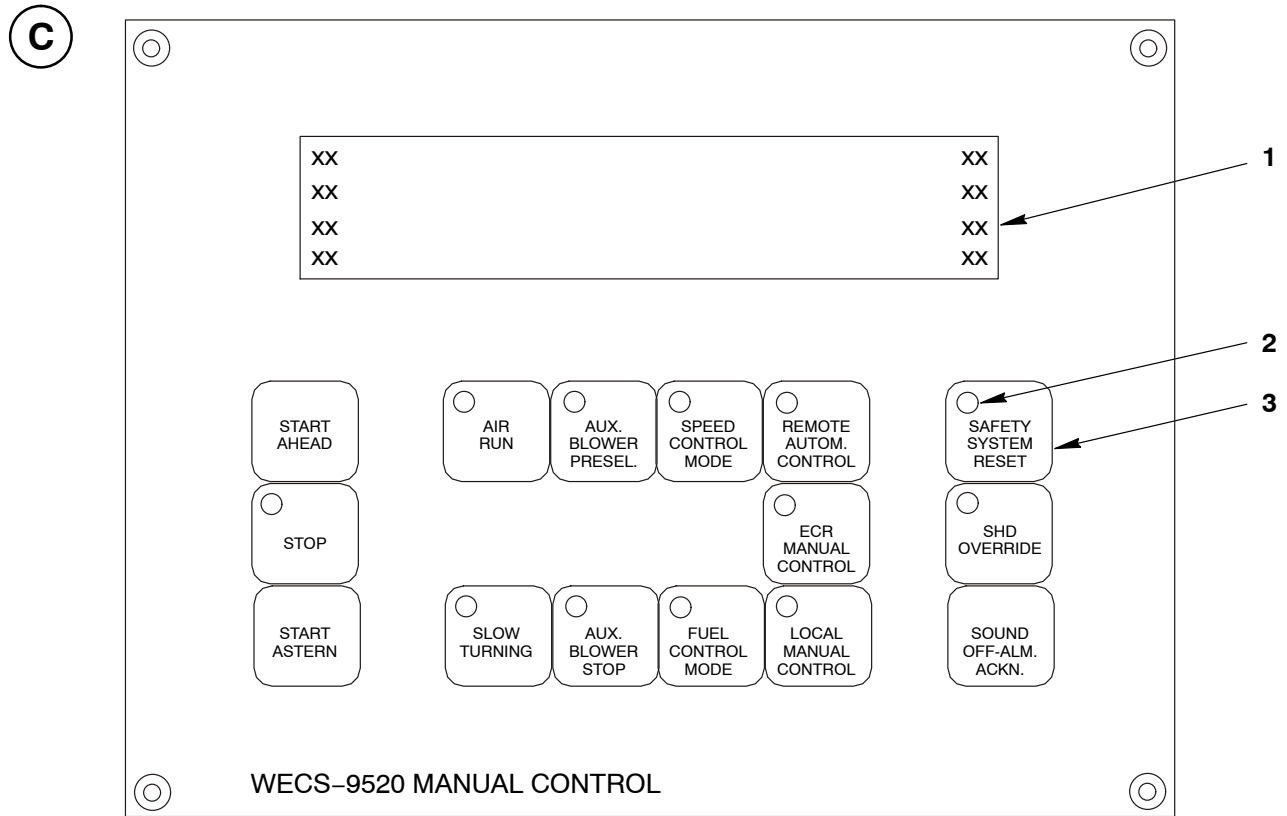

Key to illustration:

'C' WECS-9520 manual control panel

- 1 LCD display
- 2 LEDs

- 3 Function buttons

A typical LCD display is shown below.

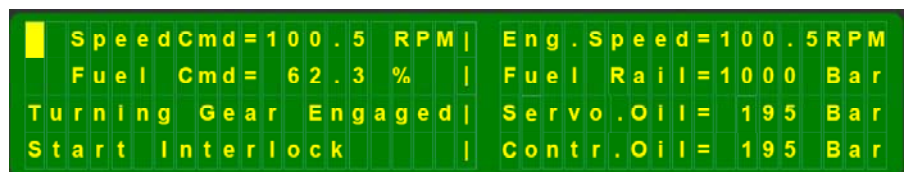

Important conditions are shown on the left in the third and fourth lines as follows:

- Turning Gear Engaged and No Aux. Blower Running
- Emergency stop
- Overspeed
- Shut-down signal active
- Shut-down signal is possible
- Slow-down signal request
- Start interlock (together with an indication in the third line)

Local Control Panel

Button			Function	Effect / Procedure
Name	Color	LED		
START AHEAD	GREEN	None	Engine START AHEAD Interruption running ASTERN (reversing from ASTERN - AHEAD)	Auxiliary blower preselect signal is activated automatically.
STOP	GREY	RED	Engine STOP interrupts fuel injection	LED comes on while STOP is selected.
START ASTERN	RED	None	Engine START ASTERN Interruption running AHEAD (reversing from AHEAD - ASTERN)	Auxiliary blower preselect signal is generated automatically
AIR RUN	GREY	GREEN	Engine start with starting air only (fuel command adjusted to zero) After a longer shut-down period or maintenance with open indicator valves	LED comes on while button is selected. Operates only when the engine is stopped.
AUX. BLOWER PRESEL.	GREY	GREEN	Sets the auxiliary blower status from STOP to PRESELECT	LED comes on when auxiliary blowers are preselected. Push the buttons AUX. BLOWER PRESEL. or START AHEAD / START ASTERN to activate.
SPEED CONTROL MODE	GREY	GREEN	Setting of speed nominal value to electronic speed control system, adjustable by rotary knob (speed / fuel)	LED comes on, if SPEED CONTROL MODE is selected LED FUEL CONTROL MODE goes off.
REMOTE AUTOM. CONTROL	GREY	GREEN	Transfer LOCAL MANUAL CONTROL (Local Control) to REMOTE AUTOM. CONTROL (Remote Control)	During control transfer, the two green LEDs flash, then come on constantly after takeover
ECR MANUAL CONTROL	GREY	GREEN	Transfer LOCAL MANUAL CONTROL (Local Control) to ECR MANUAL CONTROL	During control transfer, the two green LEDs flash, then come on constantly after takeover
SLOW TURNING	GREY	GREEN	Releases an automatic SLOW TURNING (AHEAD) Select the button again to stop the slow turning sequence	LED flashes during SLOW TURNING Programme is stopped automatically, if the engine completed one full turn, or there was a malfunction
AUX. BLOWER STOP	GREY	RED	Sets auxiliary blowers to off manually	LED comes on, if auxiliary blowers are set to off (start signal to auxiliary blowers cancelled)

Local Control Panel

Button			Function	Effect / Procedure
Name	Color	LED		
FUEL CONTROL MODE	GREY	RED	Setting of fuel injection quantity to WECS-9520. Adjustable with the rotary knob (speed / fuel)	LED comes on when FUEL CONTROL MODE is selected. If the speed control system becomes defective, or if fuel injection quantity adjustment is necessary
LOCAL MANUAL CONTROL	GREY	GREEN	Transfer from ECR MANUAL CONTROL to LOCAL MANUAL CONTROL (Local Control) Transfer from REMOTE AUTOM. CONTROL (Remote Control) to LOCAL MANUAL CONTROL (Local Control)	After takeover of control, the two green LEDs come on Transfer to LOCAL MANUAL CONTROL must be accepted at the control room console
SAFETY SYSTEM RESET	GREY	GREEN	Resets the blocked shut-down conditions	LED comes on if all shut-down conditions are the same as those before and all shut-down signals can be reset
SHD OVERRIDE	GREY	RED	Overrides the shut-down signals Override reset (LED is on constantly)	If a shut-down can be overridden, the LED flashes or comes on constantly Goes back to the condition before (i.e. of a shut-down signal that stays indicated or is not reset)
SOUND OFF – ALM ACKN.	GREY	None	Sets to off the acoustic alarms (bell / buzzer) Data about the version and a check of the software on the display	(Shut-down) alarm indications that flash change to alarm indications that come on constantly. Push the button for approximately five seconds

Intentionally blank

Pick-up for Speed Measurement

1. General

Proximity sensors are installed in a speed pick-up unit 1 attached to the front face of the column at the driving end (see Fig. 'A'). The proximity sensors measure the engine speed (rpm).

For safety, there are three electrically isolated proximity sensor groups as follows:

- Speed detection in the RCS
- Overspeed safety system
- Speed control system.

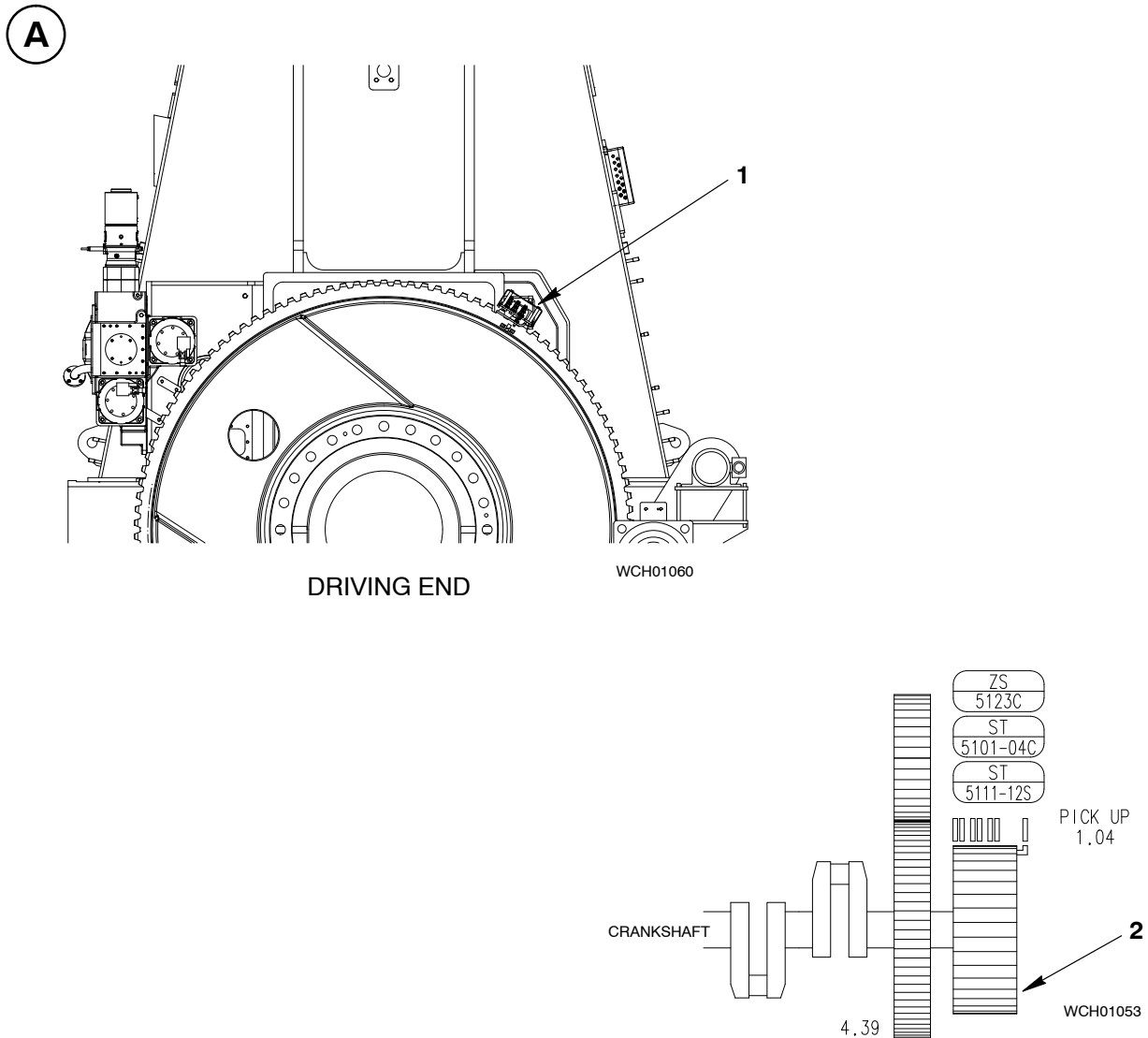

Key to Illustration: 'A' Location of speed pick-up unit
 1 Speed pick-up unit 2 Flywheel

Pick-up for Speed Measurement

2. Function

The proximity sensors 3 measure the speed of the flywheel 2 (see Fig. 'B'). Each time a tooth passes a proximity sensor, a signal is sent through the DENIS-9520 to the RCS. The RCS monitors the load and speed-related functions and sends data to the speed indication instruments.

The crank angle mark 5 is the reference point for the WECS-9520. Each time the crank angle mark 5 passes the proximity sensor 4, a signal is sent to the crank angle transmitters. This signal gives indications to compare the measurement of the TDC position for cylinder No. 1.

B

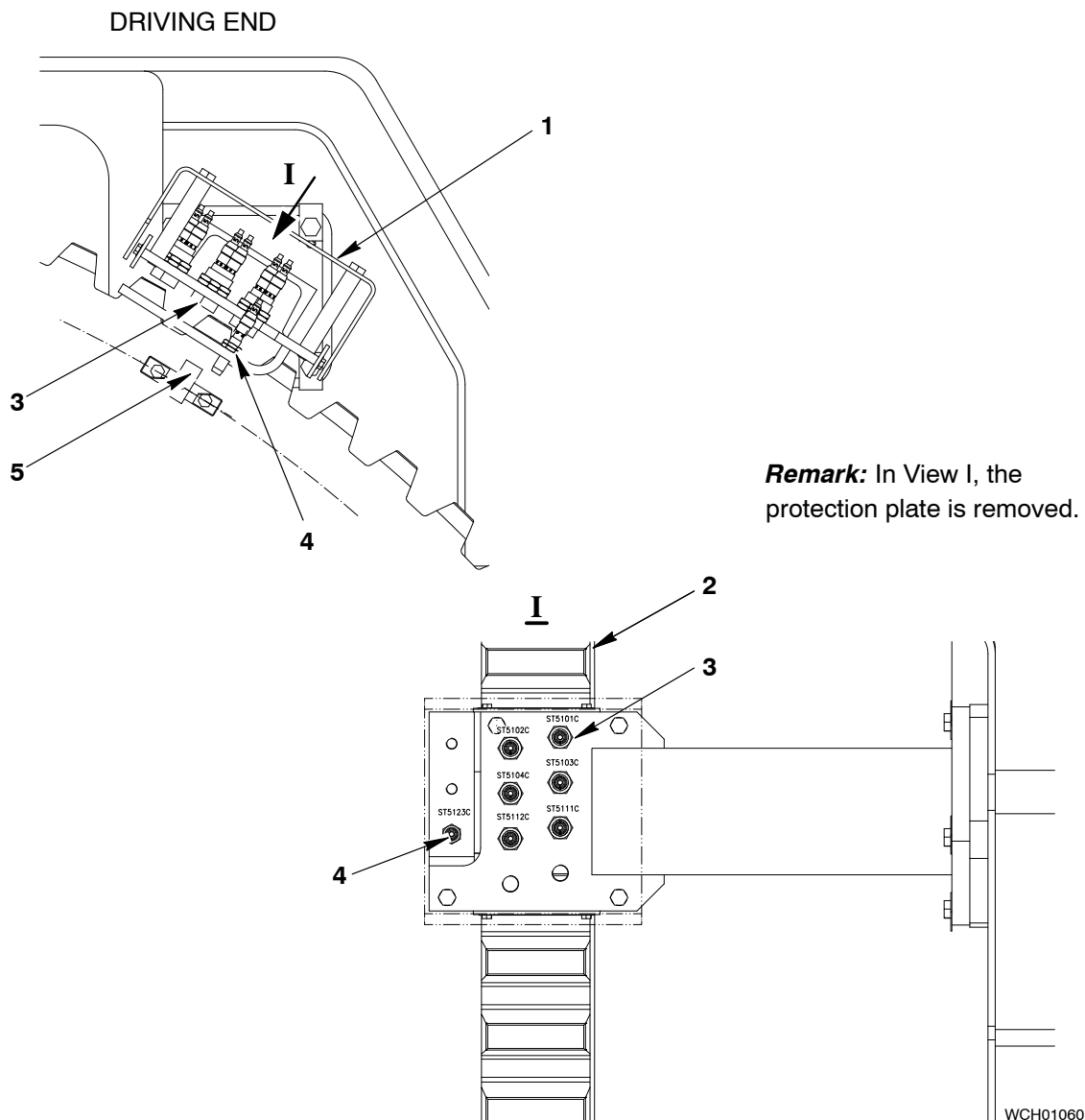

Key to Illustration:

- 1 Protection plate
- 2 Flywheel
- 3 Proximity sensors (flywheel)

'B' Proximity sensors

- 4 Proximity sensor (crank angle)
- 5 Crank angle mark

Supply Unit, Servo Oil Pump and Fuel Pump

Group 5

Servo Oil Pump	5551-1/A1
Supply Unit	5552-1/A1
Fuel Pump	5556-1/A1
Cutting Out and Cutting In of the Fuel Pump	5556-2/A1
Fuel Pressure Control Valve 3.06	5562-1/A1
Regulating Linkage	5801-1/A1

Intentionally blank

Servo Oil Pump

1. General

Two servo oil pumps 2 are built in to the supply unit 1 (see Supply Unit 5552-1). The pumps supply high pressure (HP) servo oil, which operates the exhaust valves, injection control unit and the injection valves. Bearing oil flows from the main bearing oil supply through the automatic filter 7 to the servo oil pumps.

2. Function

During usual operation, the full servo oil load is equally supplied to both pumps.

The electrically operated pressure control system (the nominal pressure value is related to the engine load) adjusts the servo oil pressure for the whole load range, i.e. high pressure (approximately 200 bar) at high engine load, and decreased pressure at low engine load.

Shearable overload protection 'OP' on the shaft 6 prevents full damage to the gear wheel 4 if a pump seizes (see Fig. 'B').

If a servo oil pump becomes defective, it is possible to operate the engine over the full load range.

The flow sensors 9 monitor the oil supply in each of the inlet pipes to the servo oil pumps 2. A possible failure of a servo oil pump 2 shows in the alarm and monitoring system.



Attention! Do not operate the engine for a long period if one of the servo oil pumps becomes defective. If the other servo oil pump fails, the engine cannot operate. Replace a defective servo oil pump as soon as possible (see the Maintenance Manual 5552-1).

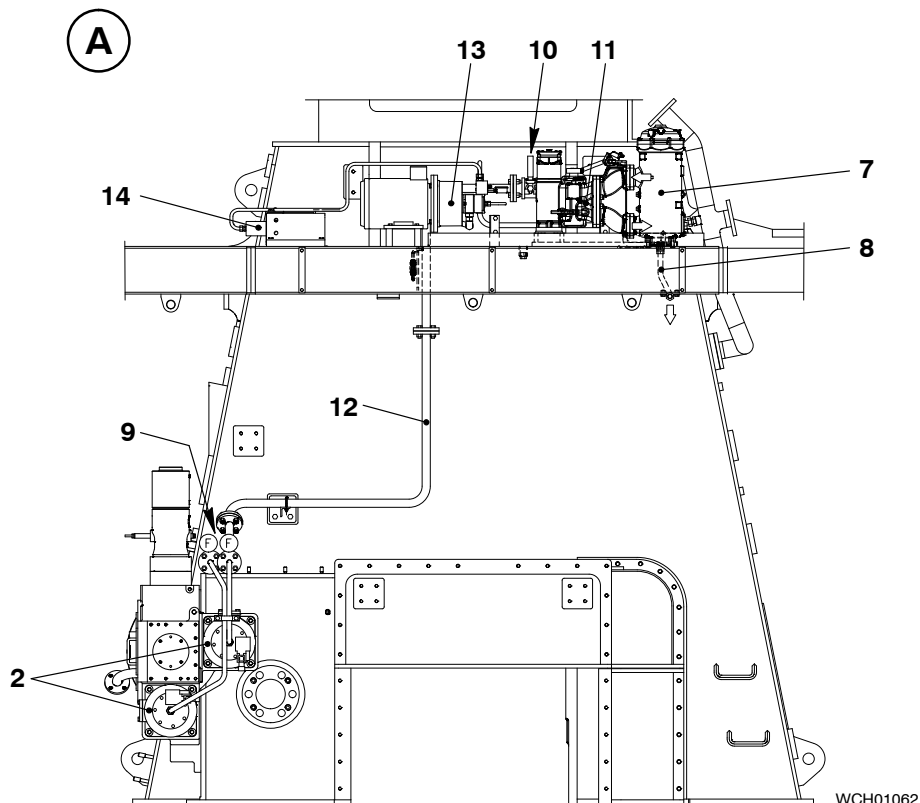

WCH01062

Servo Oil Pump

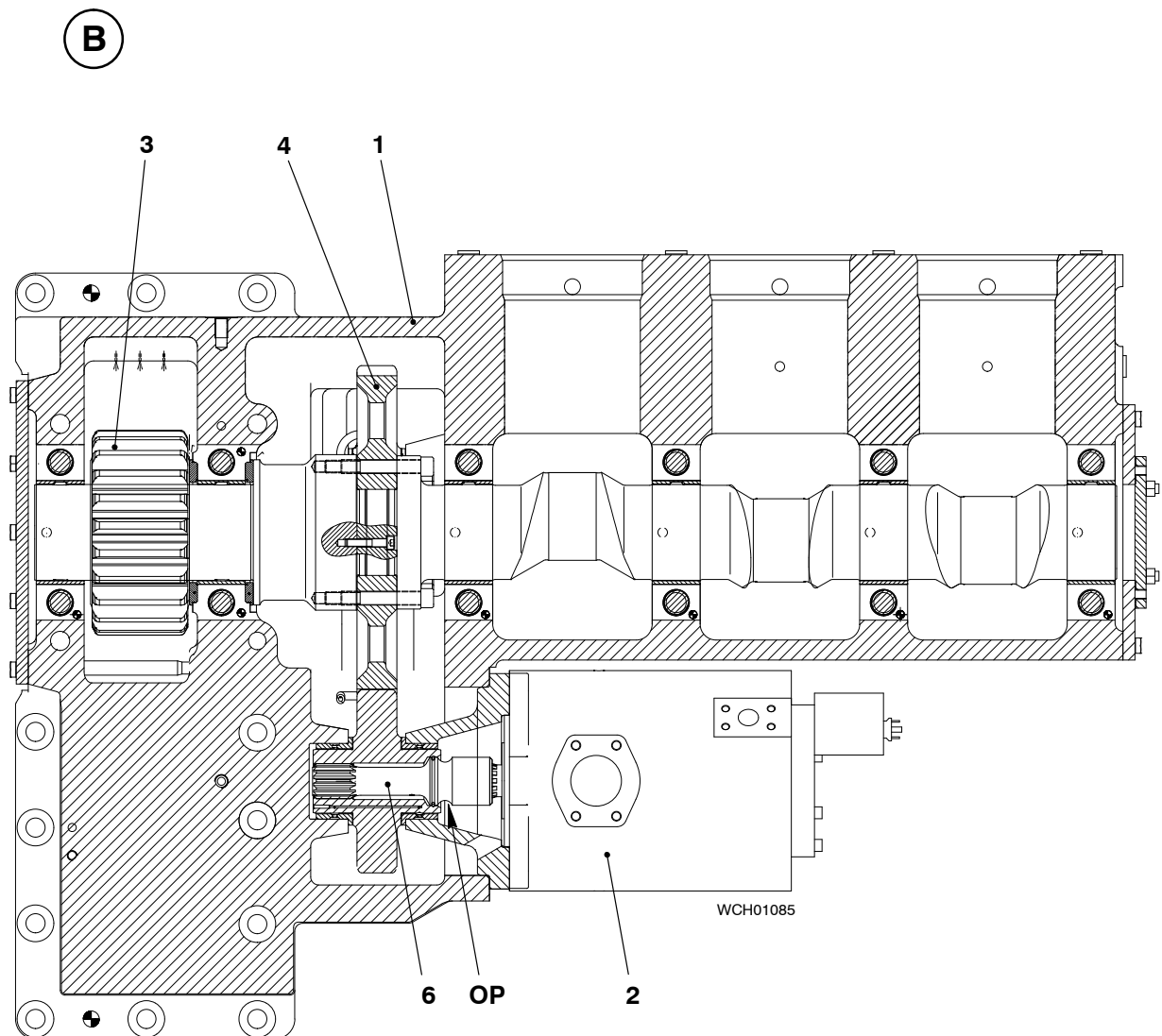

Key to Illustrations: 'A' Location of automatic filter
 'B' Location of servo oil pump

- | | |
|---------------------------------|-------------------------------------------------------------|
| 1 Supply unit | 10 Ball valve 4.37 |
| 2 Servo oil pump 4.15 | 11 Oil inlet / outlet |
| 3 Gear wheel 4.42 | 12 Supply pipe 4.51 |
| 4 Gear wheel 4.44 | 13 Servo oil service pump 4.88 |
| 5 Pinion 4.45 | 14 Intermediate piece (to HP servo oil pipes) |
| 6 Shaft 4.50 | |
| 7 Automatic filter 4.20 | |
| 8 Flushing oil outlet | |
| 9 Flow sensor 4.54 (FS2061-62A) | OP Shearable overload protection
(specified break point) |

Supply Unit

1. General

The supply unit is installed on the column and bedplate on fuel side (see Drive Supply Unit [4104-1](#)).

The supply unit includes the servo oil and fuel supply and their operation and control systems.

The components that follow are built in or, installed on the supply unit housing:

Camshaft connection:

The camshaft connection includes the camshaft 2, gear wheel shaft 3, gear wheels 4 and 5 for the camshaft and the pinion 6. The head screws 7 attach the gear wheel 5 to the shaft 3. The bearing halves 8 and thrust bearing ring halves 9 keep the camshaft in position.

Servo oil pumps:

Two servo oil pumps 10 are installed on the front of the supply unit. The gear wheel 5, pinion 6 and shaft 11 operate the servo oil pumps.

For more data, see [5551-1](#) Servo Oil Pump.

Fuel pumps:

Three fuel pumps 12 are installed in line on the supply unit.

For more data, see [5556-1](#) Fuel Pump.

Regulating linkage:

A fuel pump actuator 13 is installed on each fuel pump. The actuators control the three fuel pumps at the same time.

For more data, see [5801-1](#) Regulating Linkage.

2. Lubrication

Oil flows through the inlets OI to the bores 'OB' and the nozzles 14 to lubricate the fuel pumps and bearings.

Supply Unit

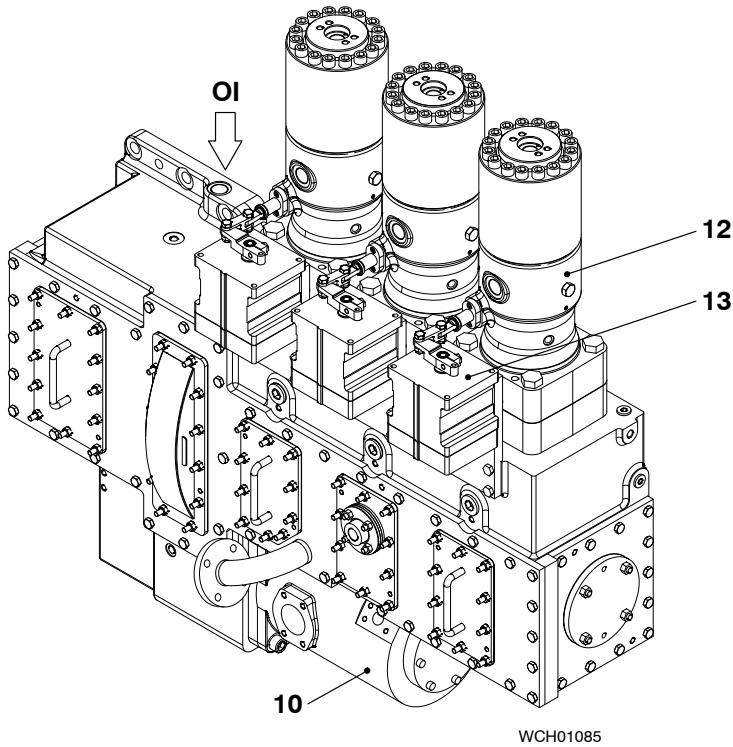
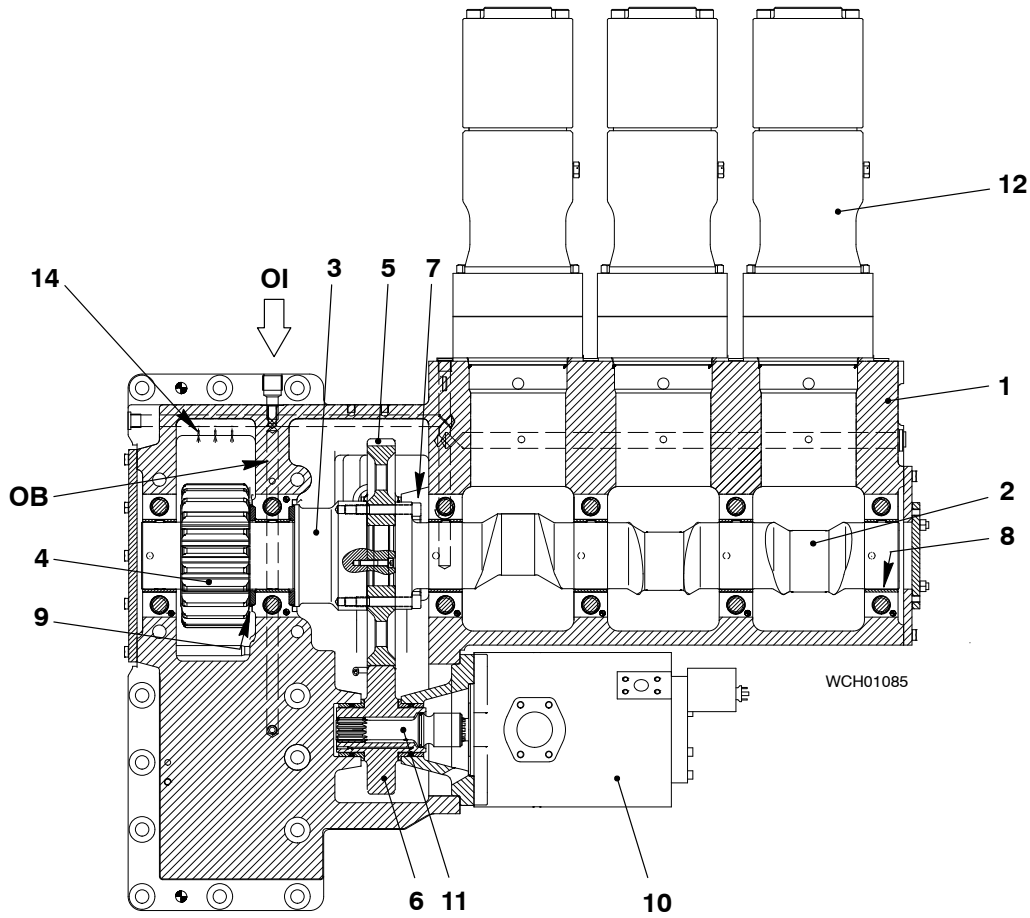

Key:

- 1 Housing
- 2 Camshaft 3.55
- 3 Shaft
- 4 Gear wheel 4.42
- 5 Gear wheel 4.44
- 6 Pinion 4.45
- 7 Head screw
- 8 Bearing half
- 9 Thrust bearing ring half
- 10 Servo oil pump 4.15
- 11 Shaft 4.50
(with shearable overload protection)
- 12 Fuel pump 3.14
- 13 Fuel pump actuator 3.21
- 14 Nozzles
- OB Oil bore
- OI Oil inlet

Fuel Pump

1. General

Three fuel pumps 1 are installed on the supply unit (see Fig. 'A'). The fuel pumps supply high pressure fuel through the HP fuel pipes to the fuel rail.

The fuel pumps are controlled to supply as much fuel to keep the necessary pressure (which is load related) in the fuel rail.

A

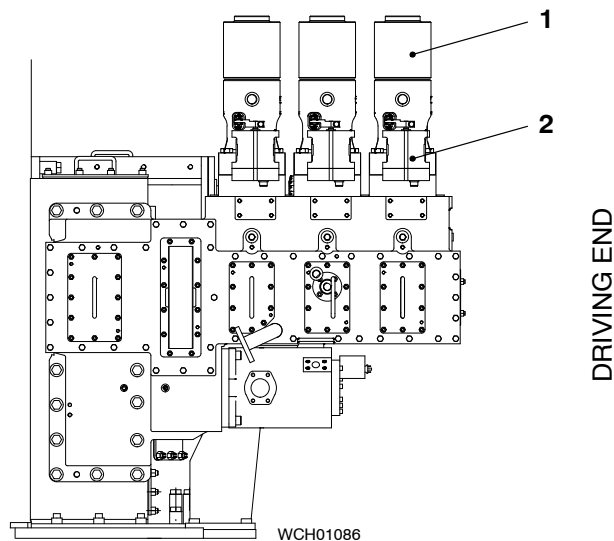

2. Function

The compression spring 11 keeps the lower carrier 13 against the guide piston 12, which in turn keeps the roller 14 against the cam 16. When the cam 16 moves the roller 14 up, the guide piston 12 moves up and the lower spring carrier 13 compresses the compression spring 11. The pump plunger 18 then moves up. The control grooves 'CG' in the pump plunger 18 control the fuel quantity.

When the toothed rack 9 moves, the regulating sleeve turns. The regulating sleeve 8 turns the driver 19 and thus the pump plunger 18.

When the pump plunger passes BDC, fuel flows through the two inlet bores 'IB' and the two control grooves 'CG' into the plunger chamber 'PC' (see Fig. 'C'). The quantity of fuel that enters the plunger chamber 'PC' is related to the regulating position (between 0 for zero supply and 10 for maximum supply).



Remark: No fuel is supplied when the inlet bores 'IB' overlap the control grooves 'CG' in position 0.

The toothed rack is connected to the fuel pump actuator (see [5801-1](#) Regulating Linkage).

Fuel Pump

3. Lubrication

The fuel pump is lubricated with lube oil which enters the lower housing 3 through the inlet bore 'OI' from the supply unit housing.

Some of the lube oil lubricates the guide piston 12, the roller pin 15 and roller 14 through spot faces, annular groove and bores in the guide piston. Lube oil that flows down lubricates the running surface of the cam.

Engine lube oil also flows through the oil bores 'OB', in the upper housing 4 and the pump cylinder 17, to lubricate the regulating sleeve 8.

Leakage fuel lubricates the pump plunger 18. The leakage fuel, and the lube oil from the regulating sleeve 8, flows through the drain bores 'DB', into an internal bore in the supply unit housing.

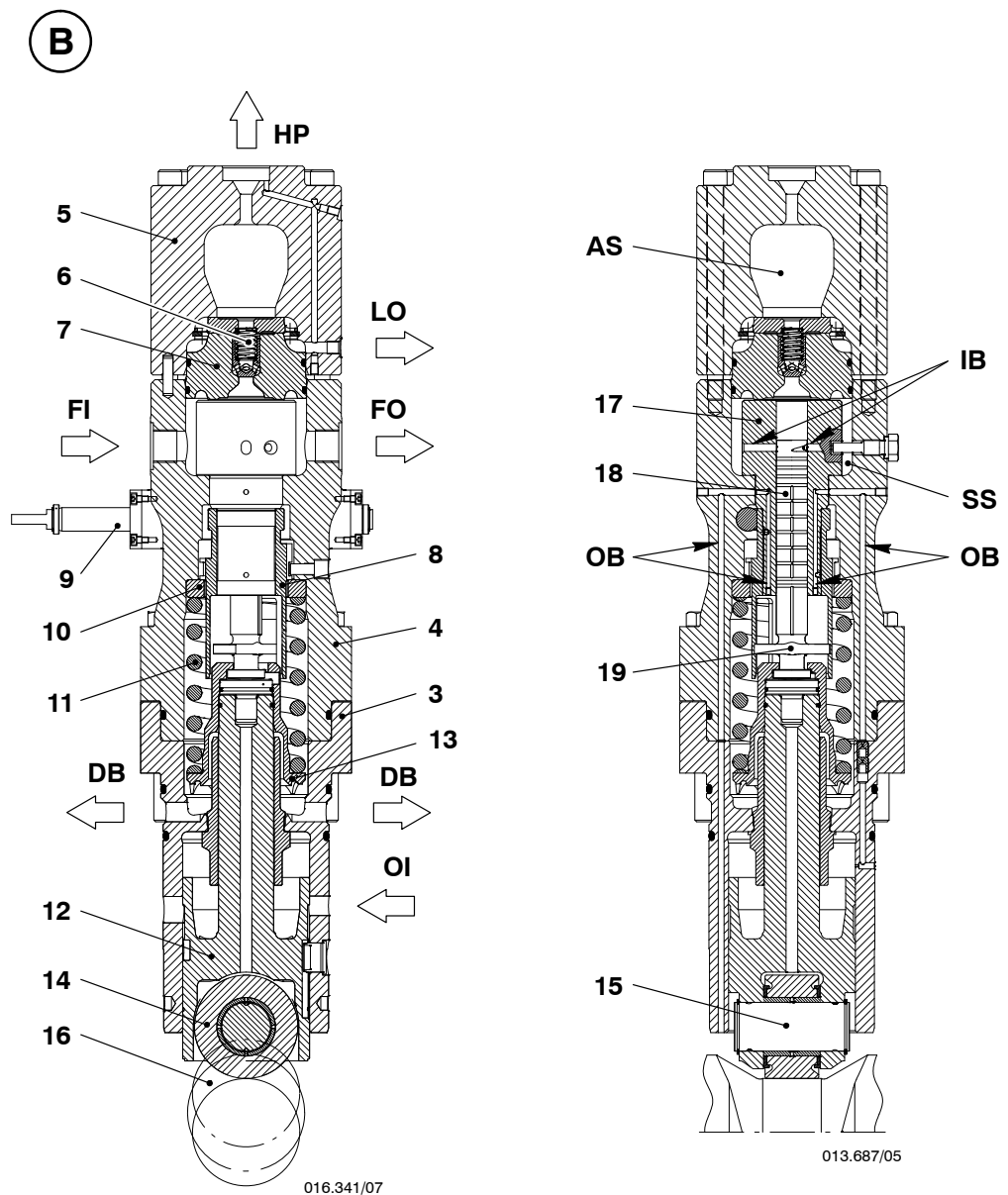

Fuel Pump

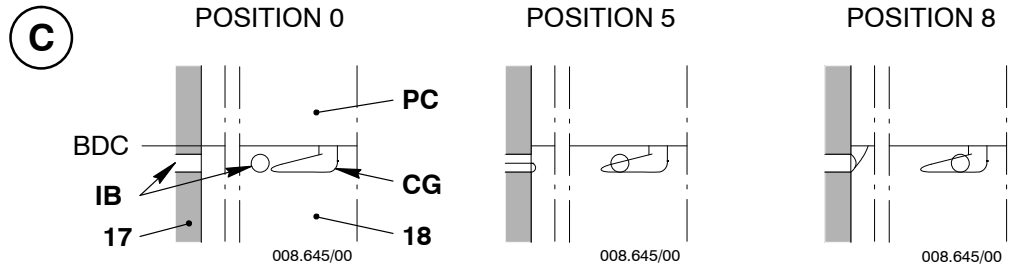

Key to Illustrations: 'A' Arrangement of fuel pump
 'B' Fuel pump
 'C' Control groove of pump plunger

- | | |
|-----------------------------------------|------------------------------------|
| 1 Fuel pump | 17 Pump cylinder |
| 2 Fuel pump actuator | 18 Pump plunger |
| 3 Lower housing | 19 Driver of pump plunger |
| 4 Upper housing | FO Fuel outlet |
| 5 Pump cover | DB Leakage fuel drain bore |
| 6 Valve body } non-return valve | FI Fuel inlet |
| 7 Valve block } | HP High pressure fuel to fuel rail |
| 8 Regulating sleeve | LO Leakage fuel outlet |
| 9 Toothed rack | OB Lubricating oil bore |
| 10 Upper spring carrier | OI Lubricating oil inlet |
| 11 Compression spring | PS Plunger space |
| 12 Guide piston | AS Accumulation space |
| 13 Lower spring carrier (with umbrella) | SS Suction space |
| 14 Roller | CG Control groove |
| 15 Roller pin | IB Inlet bore |
| 16 Cam | |

Intentionally blank

Cutting Out and Cutting In of the Fuel Pump

1. General

If a fuel pump is unserviceable (e.g. the pump plunger is seized) or the HP fuel pipe is broken (between the fuel pump and the fuel rail) the fault must be repaired immediately.

If the fault cannot be repaired, because the engine must be put back into service, it is possible to cut out the unserviceable fuel pump.



Cutting out and cutting in of unserviceable fuel pumps must only be done when the engine has stopped.



Remark: With one fuel pump cut out the engine can only be operated at decreased load:

- 5 and 6 cylinder engines – approximately 40% output
- 7 cylinder engine – approximately 70% output.

2. Cutting Out and Cutting In

2.1 Cutting out and cutting in device

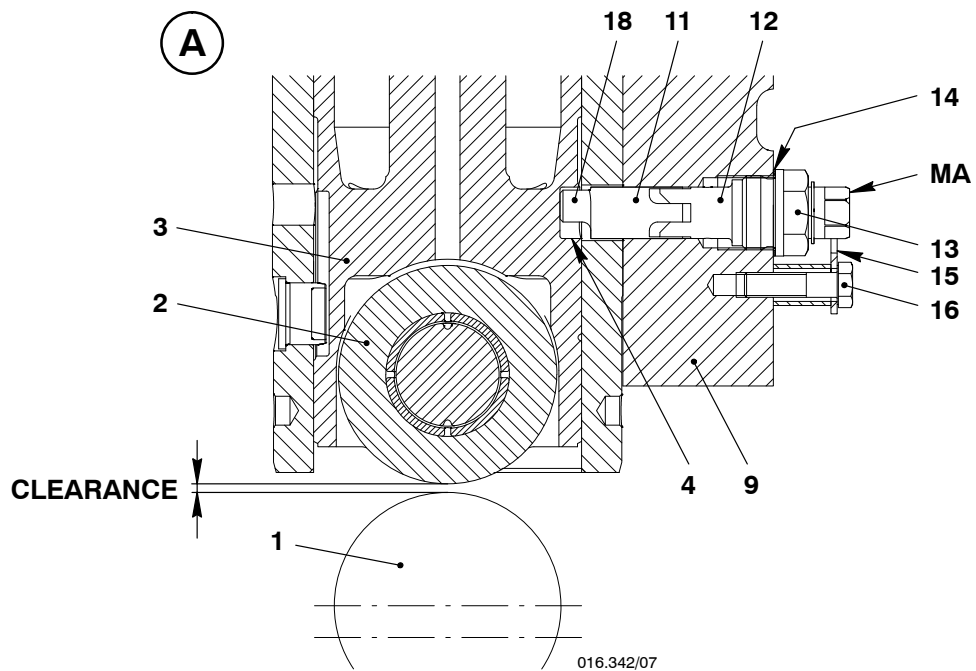

Key to Illustrations: 'A' to 'D'

1 Cam	11 Pressure pin	} tool 94430
2 Roller	12 Spring guide	
3 Guide piston	13 Guide screw	
4 Square hole	14 Gasket	
5 Screw plug	15 Claw	
6 Inspection cover	16 Screw	
7 Blank flange (tool GF 94569)	17 HP fuel pipe	
8 Blank flange (tool GF 94569A)	18 Eccentric pin	
9 Supply unit		
10 Fuel rail 3.05	MA Mark	

Cutting Out and Cutting In of the Fuel Pump

2.2 Cutting out procedure

Make sure that the engine has stopped.

- ⇒ Remove the applicable inspection cover 6 from the supply unit 9.
- ⇒ Find the position of the related cam. Use the turning gear to turn the engine until the roller 2 is at the highest position on the cam peak.
- ⇒ Remove the applicable screw plug 5 and gasket (Fig. 'B').
- ⇒ Put the roller lifting tool 94430 in position in the supply unit 9 and tighten the guide screw 13.
- ⇒ Turn the spring guide 12 and the pressure pin 11 at the same time. Make sure that the mark 'MA' points down and the eccentric pin 18 engages in the square hole 4.
- ⇒ Use an open ended ring spanner AF22 to turn the spring guide 12 and the pressure pin 11 through 180° until the mark 'MA' points up. Make sure that the eccentric pin 18 (with its spot-faced surface) lifts the guide piston 3.
- ⇒ Use the claw 15 and screw 16 to lock the spring guide 12 in position.
- ⇒ Install the inspection cover 6 to the supply unit 9.

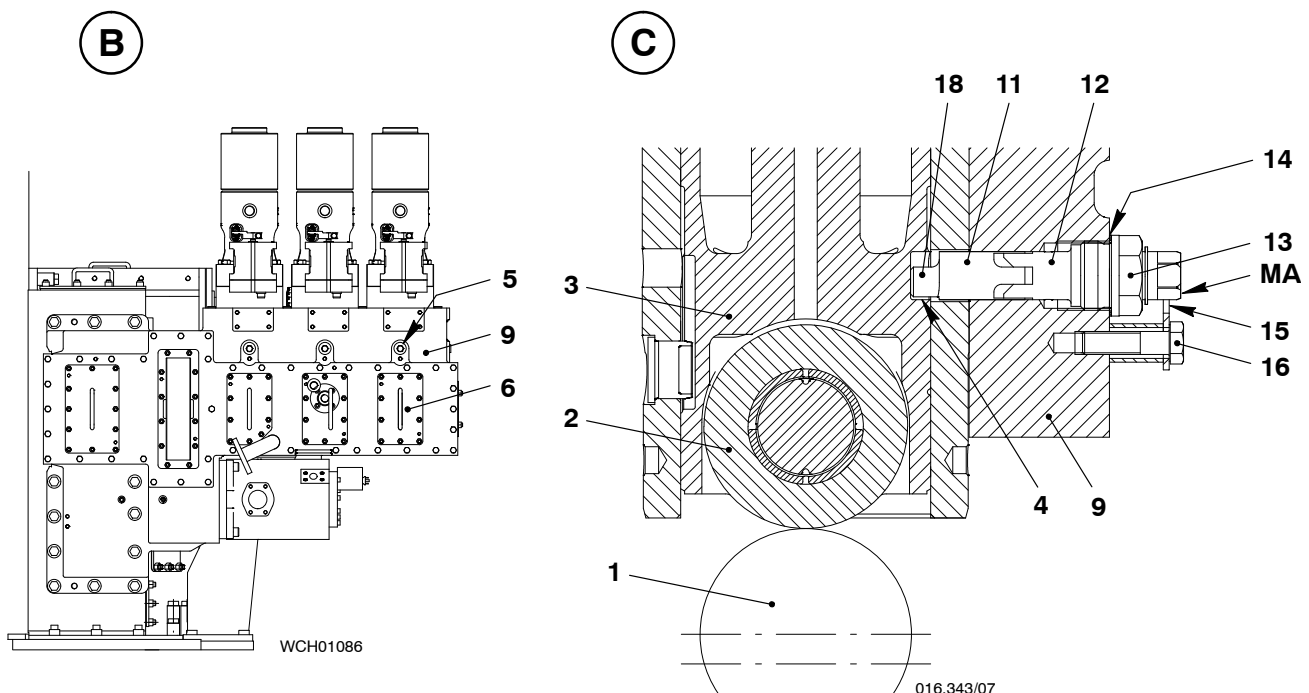

2.3 Blank off fuel pump and fuel rail



Remark: If the non-return valves leak, there can be unwanted pressure in the plunger space of the fuel pumps. This can increase the load on the roller lifting tool 94430. Do the steps that follow to prevent this unwanted pressure:

- ⇒ Remove the applicable HP fuel pipe 17 from the fuel pump that is cut-out (see Fig. 'D' and 8752-1 'Removal' in the Maintenance Manual).
- ⇒ Fit the blank flange 7 (tool GF 94569) to the fuel pump.
- ⇒ Fit the blank flange 8 (tool GF 94569A) to the fuel rail.



Remark: For the torque values and lubricant of the applicable screws, see 0352-1 in the Maintenance Manual.

Cutting Out and Cutting In of the Fuel Pump

2.4 Cutting in procedure

Make sure that the engine has stopped.

- ⇒ Remove the applicable inspection cover 6 from the supply unit 9.
- ⇒ Find the position of the related cam. Use the turning gear to turn the engine until the roller 2 is at the highest position on the cam peak.
- ⇒ Remove the screw 16 and the claw 15.
- ⇒ Use an open ended ring spanner AF22 to turn the spring guide 12 and pressure pin 11 through 180° until the mark 'MA' points down. (Fig. 'C').
- ⇒ Loosen the guide screw 13, then remove the tool 94430 and gasket 14.
- ⇒ Install the gasket and the screw plug 5.
- ⇒ Remove the blank flanges 7 and 8.
- ⇒ Install the HP fuel pipe 17 (see also 8752-1 'Fitting' in the Maintenance Manual).

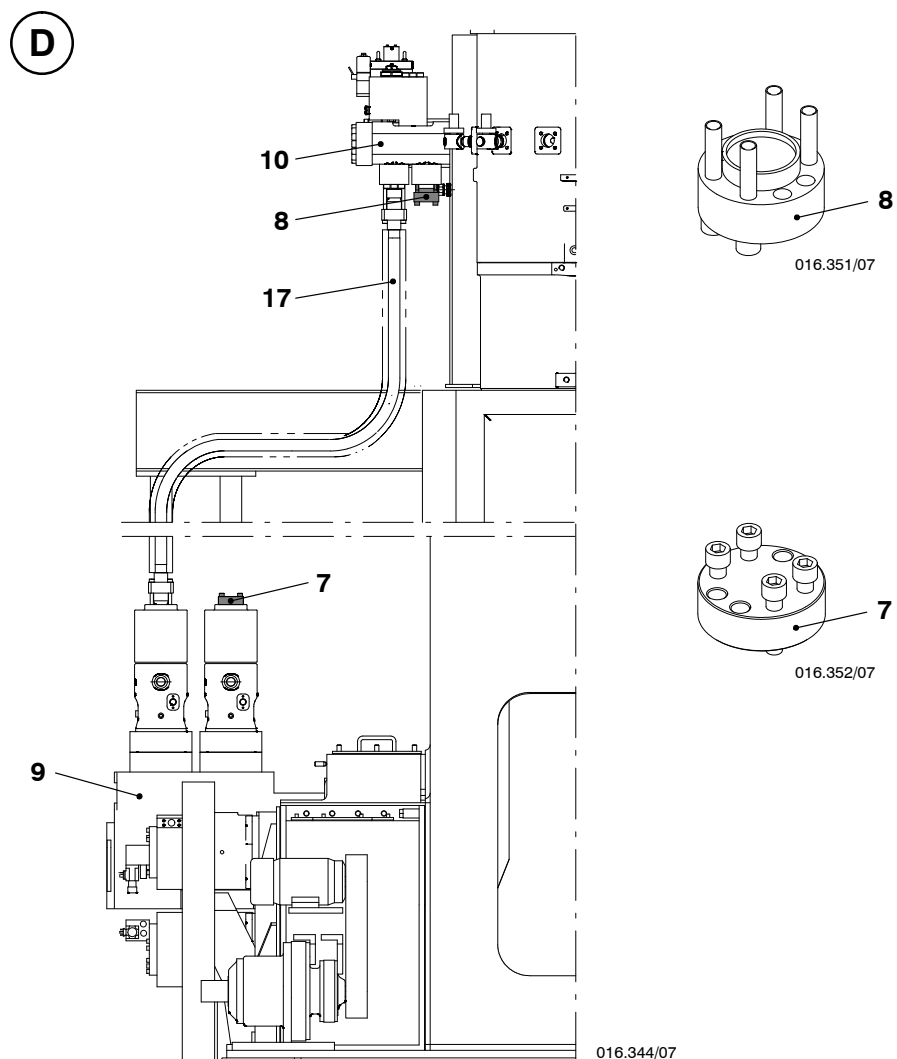

Intentionally blank

Fuel Pressure Control Valve 3.06

1. General

1.1 Usual operation



Attention! In usual operation, make sure that the knurled screw 8 is turned fully clockwise (down).

WECS-9520 regulates the fuel pressure, which stays below the opening pressure of the fuel pressure control valve 1. The fuel pressure control valve is usually closed (see also 4002-1 'Fuel pressure control').

The fuel pressure control valve is a pressure relief valve and opens if the fuel pressure is more than approximately 1050 bar. The adjusting disc 7 and the knurled screw 8 set the correct opening pressure.

1.2 Emergency stop

The safety system activates the fuel shut-down pilot valve 6, which decreases the fuel pressure to less than 200 bar (in most conditions to 0 (zero) bar). Therefore an injection is not possible.



Remark: The fuel shut-down pilot valve is one of three devices to shut down the engine. The other devices are:

- Immediate injection stop (WECS-9520)
- Fuel pump delivery to 0 (zero).

1.3 Emergency operation



Attention! For emergency operation, make sure that the knurled screw 8 is turned fully counterclockwise (up).

If there is a failure in the fuel pressure regulating system, the fuel pressure control valve will control the fuel pressure regulating function when:

- There are missing or incorrect control signals
- The fuel pump actuator(s) is/are out of service
- A toothed rack is blocked.

The toothed rack(s) of the fuel pump(s) are locked in the middle position. This can be applied to one fuel pump, or all fuel pumps that relate to the failure (see 0515-1 'Defective actuator').

If the fuel pressure is more than the opening pressure, the fuel pressure control valve will open, which gradually drains sufficient fuel to keep the adjusted maximum pressure. If this occurs, a longer operating period must be prevented.

The knurled screw must be turned fully counterclockwise (up) against the stop, which decreases the opening pressure to approximately 600 bar. This makes sure of safe operation over the whole load range.



Remark: When the fuel pressure control valve opens, a loud whistling noise indicates when fuel drains.

Fuel Pressure Control Valve 3.06

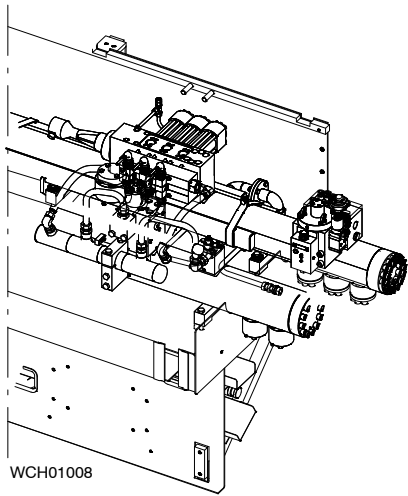

A

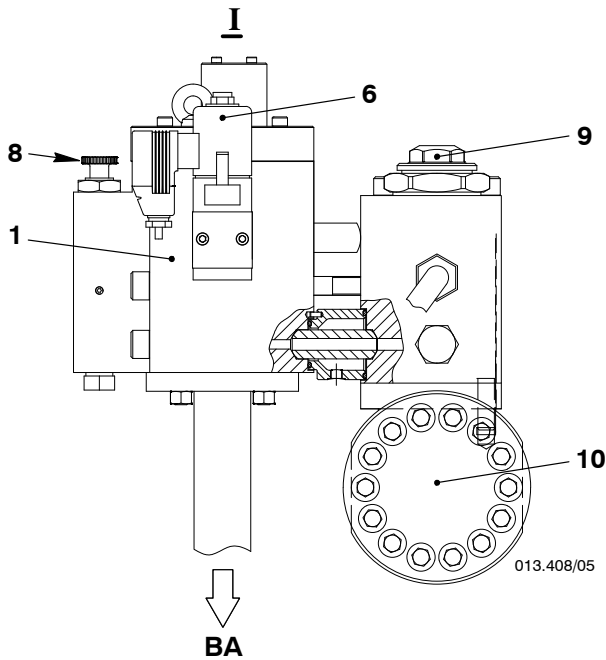
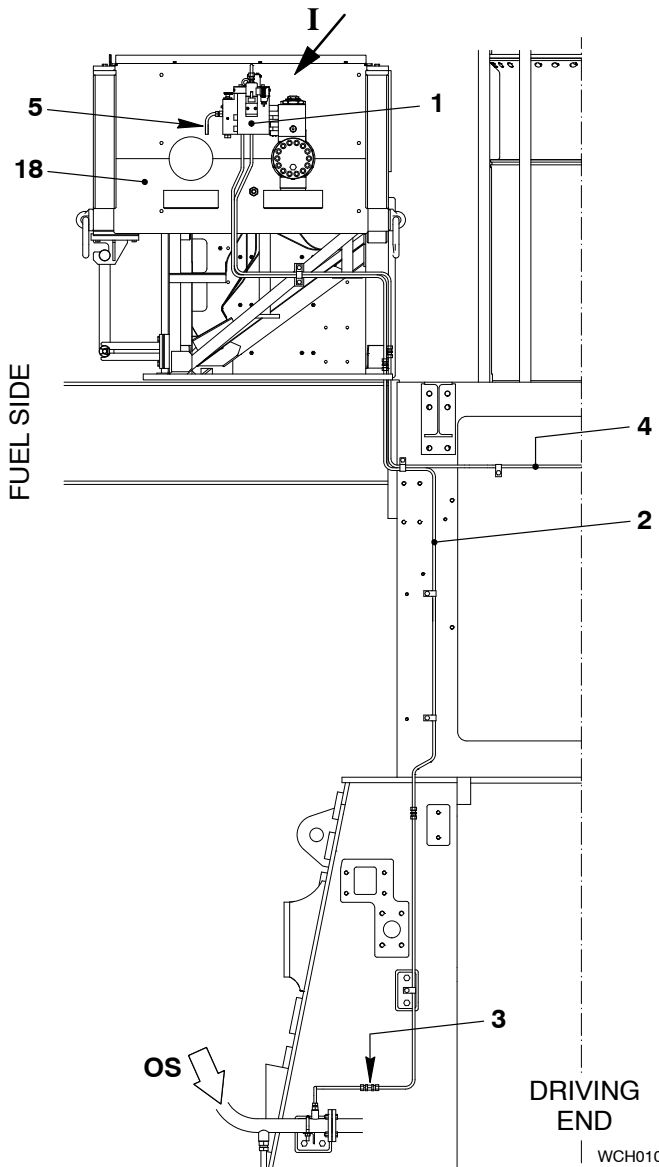

Key to Illustrations: 'A' Location of the fuel pressure control valve 3.06
 'B' Fuel pressure control valve 3.06

- | | |
|---------------------------------------|-------------------------------|
| 1 Fuel pressure control valve 3.06 | 13 Valve seat |
| 2 Bearing oil supply pipe | 14 Compression spring |
| 3 Non-return valve 3.67 | 15 Compression spring |
| 4 Bearing oil drain | 16 Filter |
| 5 Leakage control pipe | 17 Oil pressure control valve |
| 6 Fuel shut-down pilot valve 3.08 | 18 Rail unit |
| 7 Adjusting disc | |
| 8 Knurled screw | |
| 9 Fuel overpressure safety valve 3.52 | FO Fuel outlet (drain) |
| 10 Fuel rail 3.05 | FI Fuel inlet |
| 11 Piston | OI Oil inlet |
| 12 Valve tip | OS Oil supply (main bearing) |

Fuel Pressure Control Valve 3.06

2. Function

2.1 Control function

Oil pressure on the piston 11 pushes the valve tip 12 down on to the valve seat 13. The fuel pressure also operates against the oil pressure control valve 17. When the fuel pressure increases, the oil pressure decreases. If the oil pressure decreases below a specified threshold value, the valve tip 12 moves up from the valve seat 13 and fuel is drained.

The compression springs 14, 15 and the knurled screw 8 give the control conditions of the oil pressure regulating valve 17.

2.2 Function check

During operation, carefully turn the knurled screw 8 counterclockwise until the oil pressure control valve 17 starts to open. When the oil pressure control valve functions correctly, fuel pressure is released.

2.3 Emergency stop function

If the fuel shut-down pilot valve 6 is energized, the oil pressure above the piston 11 is released. The valve tip 12 moves away from the valve seat and fuel is drained.

B

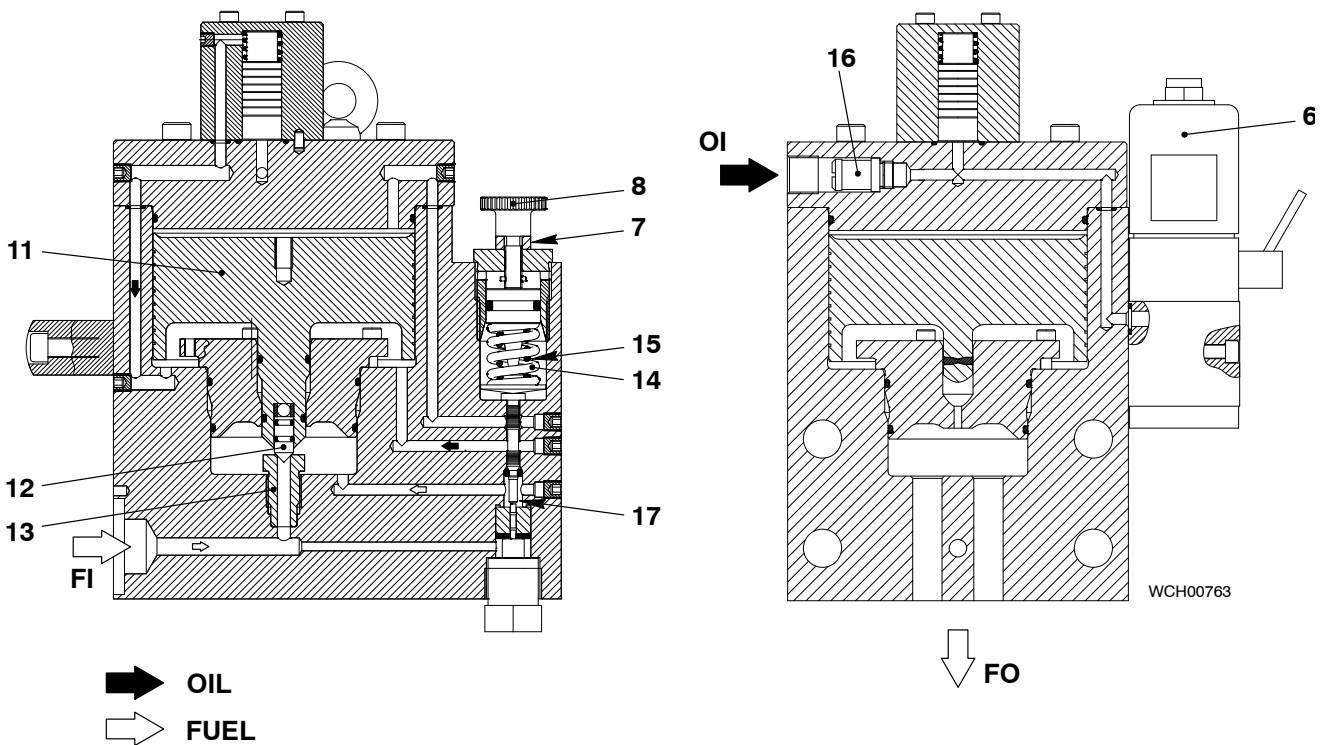

Intentionally blank

Regulating Linkage

1. General

Each fuel pump 1 has an electrically-operated actuator 2. The regulating linkage connects the actuator 2 to the fuel pump 1. The lever 3 moves the connecting element 4, which moves the toothed rack 5 to the necessary position to control the fuel flow through the fuel pump 1.

2. Function

The WECS-9520 system controls each actuator to control the fuel quantity and keep the necessary operating pressure in the fuel rail.

During normal operation, the actuators move at the same time i.e. the control positions and the fuel quantity that flows through the fuel pumps are the same.

If a pump plunger does not move, which blocks the toothed rack, electrical power to the related actuator must not be disconnected (overload protection).

5 to 7 cylinder engines:

If an actuator fails, its actuator lever 3 stays in position or turns slowly to the zero supply position. The other actuators get control of the fuel quantity supply (see also [0515-1](#) 'Defective actuator').



Remark: In the lower load range (at lower fuel consumption) fuel pressure control valve 3.06 takes over the fuel pressure regulating function. This is because the actuator(s) cannot continue to decrease the fuel quantity supply (see also [5562-1](#) 'Fuel pressure control valve 3.06').

Regulating Linkage

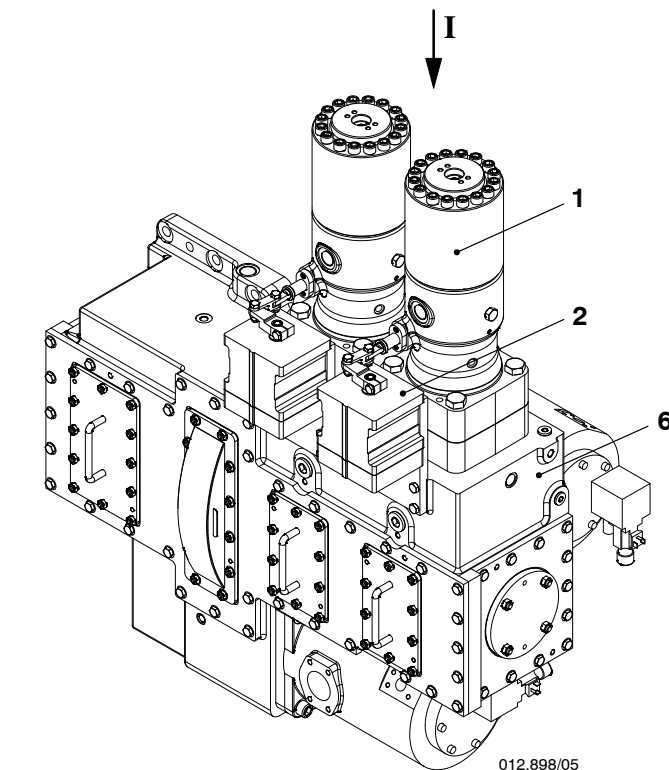
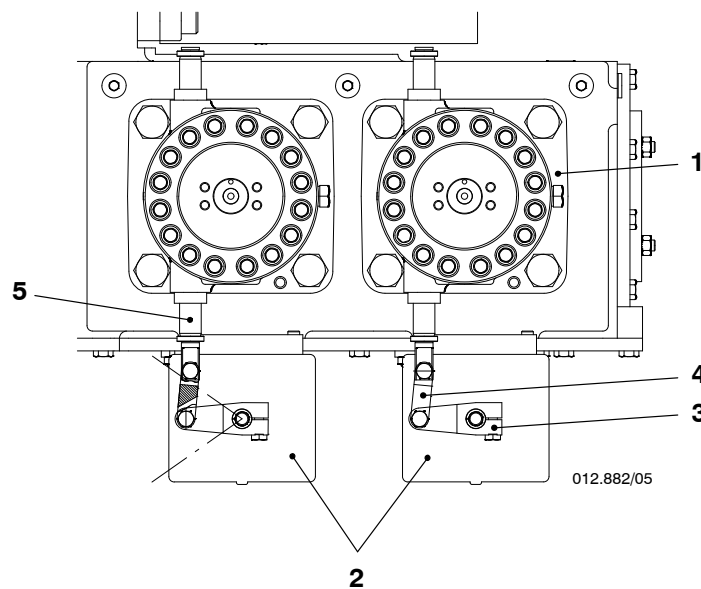
Heinzmann Actuator:**I****Key to Illustrations:**

- | | |
|------------------|----------------------|
| 1 Fuel pump 3.14 | 4 Connecting element |
| 2 Actuator 3.21 | 5 Toothed rack |
| 3 Actuator lever | 6 Supply unit |

Regulating Linkage

Woodward Actuator:

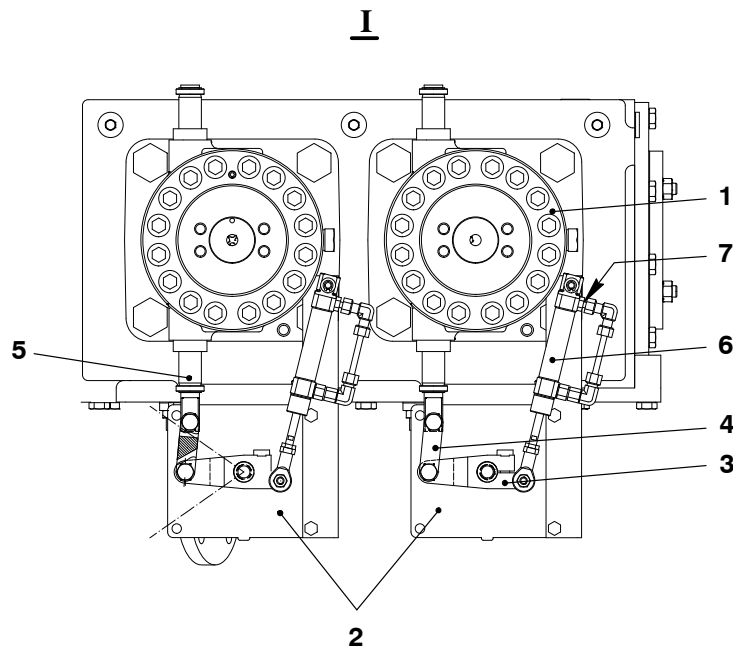
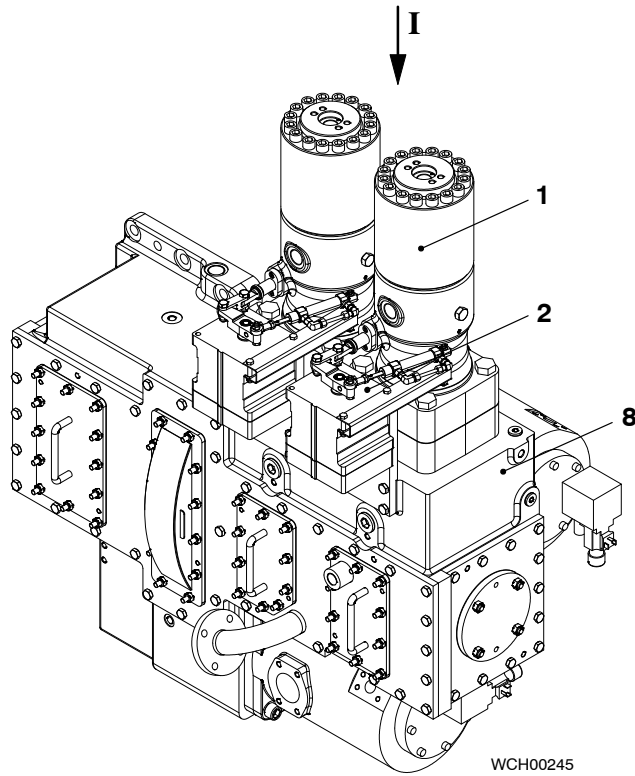

Key to Illustrations:

- | | |
|----------------------|----------------|
| 1 Fuel pump 3.14 | 5 Toothed rack |
| 2 Actuator 3.21 | 6 Damper |
| 3 Actuator lever | 7 Orifice |
| 4 Connecting element | 8 Supply unit |

Intentionally blank

Scavenge Air System

Group 6

Scavenge Air Receiver	6420-1/A1
Turbocharging	6500-1/A1

▽ **Cleaning the Turbocharger in Operation**

- Turbocharger TPL Type	6510-1/A1
- Turbocharger MET Type	6510-1/A2
- Turbocharger A100-L Type	6510-1/A3
Auxiliary Blower and Switch Box	6545-1/A1
Scavenge Air Cooler: Operating Instructions and Cleaning	6606-1/A1

Intentionally blank

Scavenge Air Receiver

1. General

The scavenge air receiver 1 is a welded assembly and attached to the cylinder block on the exhaust side. The scavenge air receiver has the parts that follow:

- Receiver
- Turbocharger support
- Air duct
- Scavenge air cooler casing.

The longitudinal wall 12 divides the receiver into the two spaces 'AS' and 'RS'. The air flaps 2 are attached to the longitudinal wall (see Fig. 'A' and Fig 'B').

2. Function

During operation, the turbocharger blows scavenge air through the scavenge air cooler (SAC) into the charging unit, through the water separator and then into the air space 'AS'. The air then flows through the air flaps 2 into the receiver space 'RS' and through openings in the cylinder block to the piston underside 'PU'. The scavenge air flows through the scavenge ports when the piston is near BDC. The air flaps 2 prevent back-flow into the air space 'AS'.

Two auxiliary blowers 7 are attached to the scavenge air receiver. During engine start or at low engine load, the auxiliary blowers come on and move scavenge air from the space 'AS' through the suction box 11 to the receiver space 'RS'. The air flaps 3 installed in the suction box 11 prevent the back-flow of air when the auxiliary blowers are set to off.

A relief valve 10 is installed behind the hinged cover 17 on the driving end of the scavenge air receiver. The relief valve opens when the air pressure increases to more than the permitted value in the receiver space 'RS'.



Remark: Different types of relief valve 10 can be installed. The relief valve can have cup springs 18 or a compression spring 19.



Attention! Do not go into the the receiver spaces 'RS' during engine operation. Access into the receiver space 'RS' is possible only when the engine has stopped.

To get access to the receiver spaces 'RS', you open the hinged covers 6.

The hinged covers 5 can be removed to examine the air flaps 3.



Remark: If the turbocharger becomes defective, the hinged covers 5 and the hinged cover 4 installed in the air duct must be opened for emergency operation. Also, if an auxiliary blower fails, do not open the cover 5 on the defective blower side (see Turbocharger out of Service [0590-1](#)).

Scavenge Air Receiver

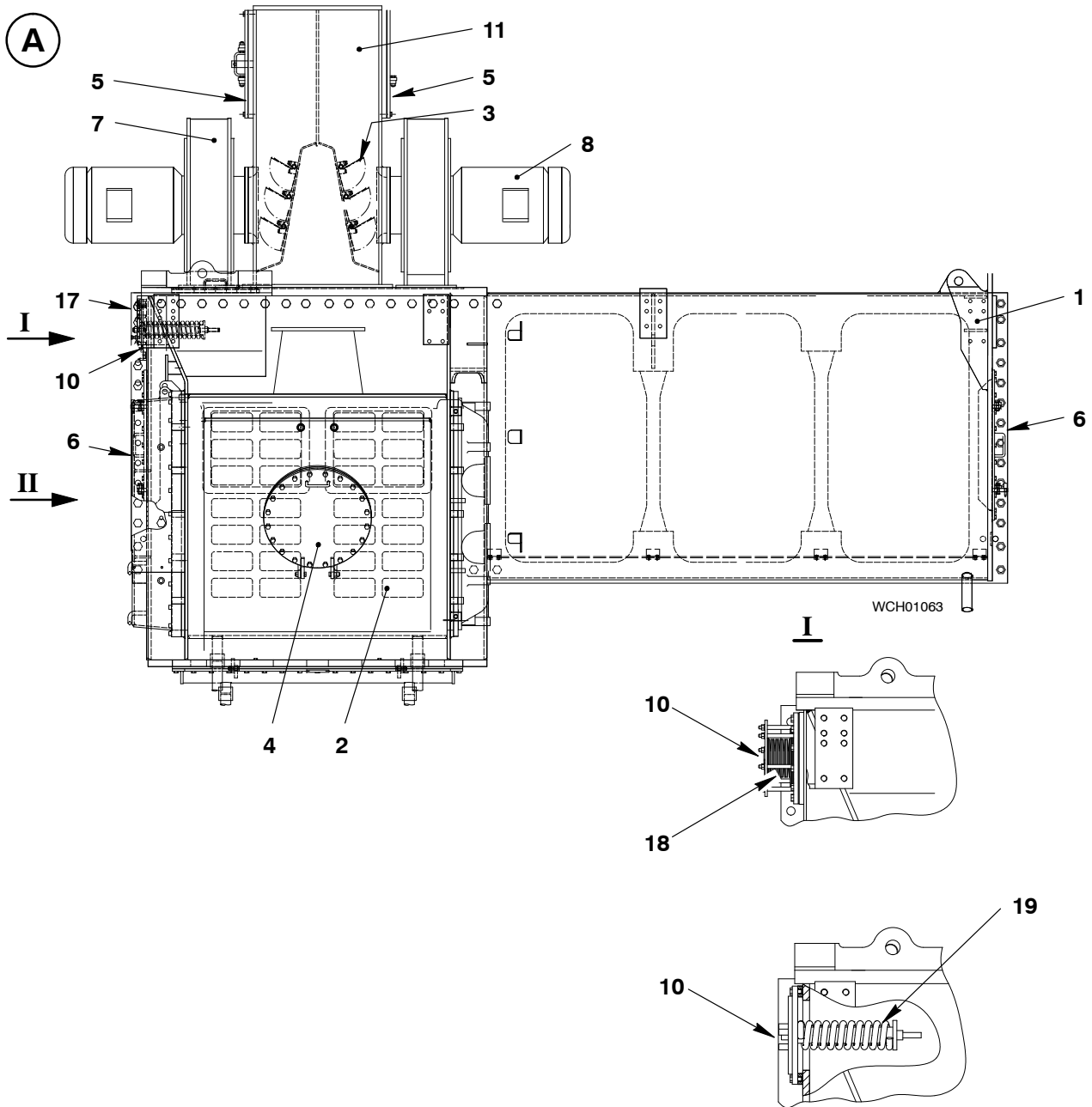

Key to Illustrations: 'A' Scavenge air receiver (side view)

- | | |
|---------------------------------|------------------------------------|
| 1 Scavenge air receiver | 8 Electric motor |
| 2 Air flaps | 10 Relief valve |
| 3 Air flaps to auxiliary blower | 11 Suction box |
| 4 Hinged cover | 17 Hinged cover (for relief valve) |
| 5 Hinged cover | 18 Cup springs |
| 6 Hinged cover | 19 Compression spring |
| 7 Auxiliary blower | |

Scavenge Air Receiver

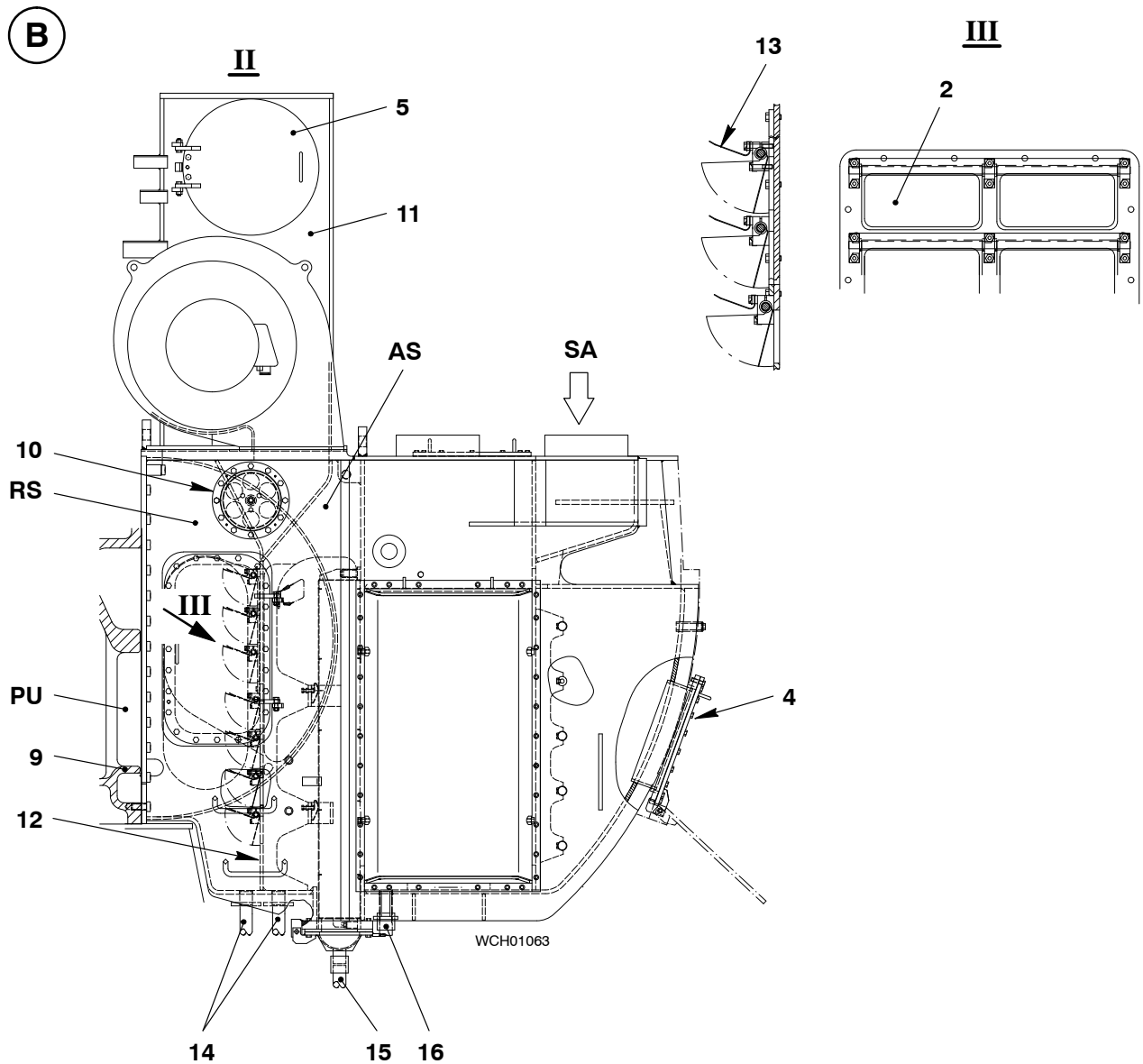

Key to Illustrations: 'B' Scavenge air receiver (end view)

- | | |
|------------------|-------------------------------------------|
| 2 Air flaps | 12 Longitudinal wall |
| 4 Hinged cover | 13 Stop plate |
| 5 Hinged cover | 14 Oily-water drain |
| 9 Cylinder block | 15 Condensate drain from water separator |
| 10 Relief valve | 16 Condensate / wash-water drain from SAC |
| 11 Suction box | |
| | PU Piston underside |
| | RS Receiver space |
| | SA Scavenge air from the turbocharger |
| | AS Air space |

Intentionally blank

Turbocharging

1. General

The turbocharger is accurately tuned to the engine and related to the number of cylinders, service output, mode of operation etc. The number of turbochargers is related to the number of cylinders on the engine.

Data about operation, maintenance and servicing are given in the related documentation of the manufacturer (which is part of the Operating Instruction).



CAUTION! Damage Hazard: If you operate the engine with a turbocharger cut out, you must obey the operation limits given in the Service Bulletin RT-162 to prevent damage to the engine.

For data about the operation limits of operation with a turbocharger cut out, see Service Bulletin RT-162.

2. Function

Exhaust gas 'EG' from the cylinders collects in the manifold 10. The exhaust gas moves the turbine 12, then flows out through the exhaust gas outlet 'EO' to the exhaust system of the vessel. The exhaust gas turns the turbine and moves the compressor 11, which is attached to the same shaft. The compressor pulls fresh air 'FA' from the engine room through a filter/silencer.

The compressor compresses and heats the scavenge air 'FA'. This hot compressed air flows into the charging unit 17 through the air cooler 16, which cools the air to a lower temperature range. Because of the high humidity in the air, the scavenge air cooler produces a large quantity of condensation. The water separator 15 removes the condensation, which flows through the drains 'WD' and 'CD'.

The scavenge air flows from the air space 'AS' through the air flaps 13 to the receiver space 'RS' and then into the piston underside 'PU'.

When the piston 6 is near BDC, charge air flows through the open inlet ports 5 into the cylinder 3.

After the compression, combustion, and expansion process, the exhaust valve 1 opens and exhaust gas 'EG' flows into the manifold 10, which completes the cycle.

During engine start, or low load operation the auxiliary blowers 7 supply air from the air space 'AS' to the receiver space 'RS'. A non-return valve prevents the back-flow of air (see also Scavenge Air Receiver [6420-1](#)).

Turbocharging

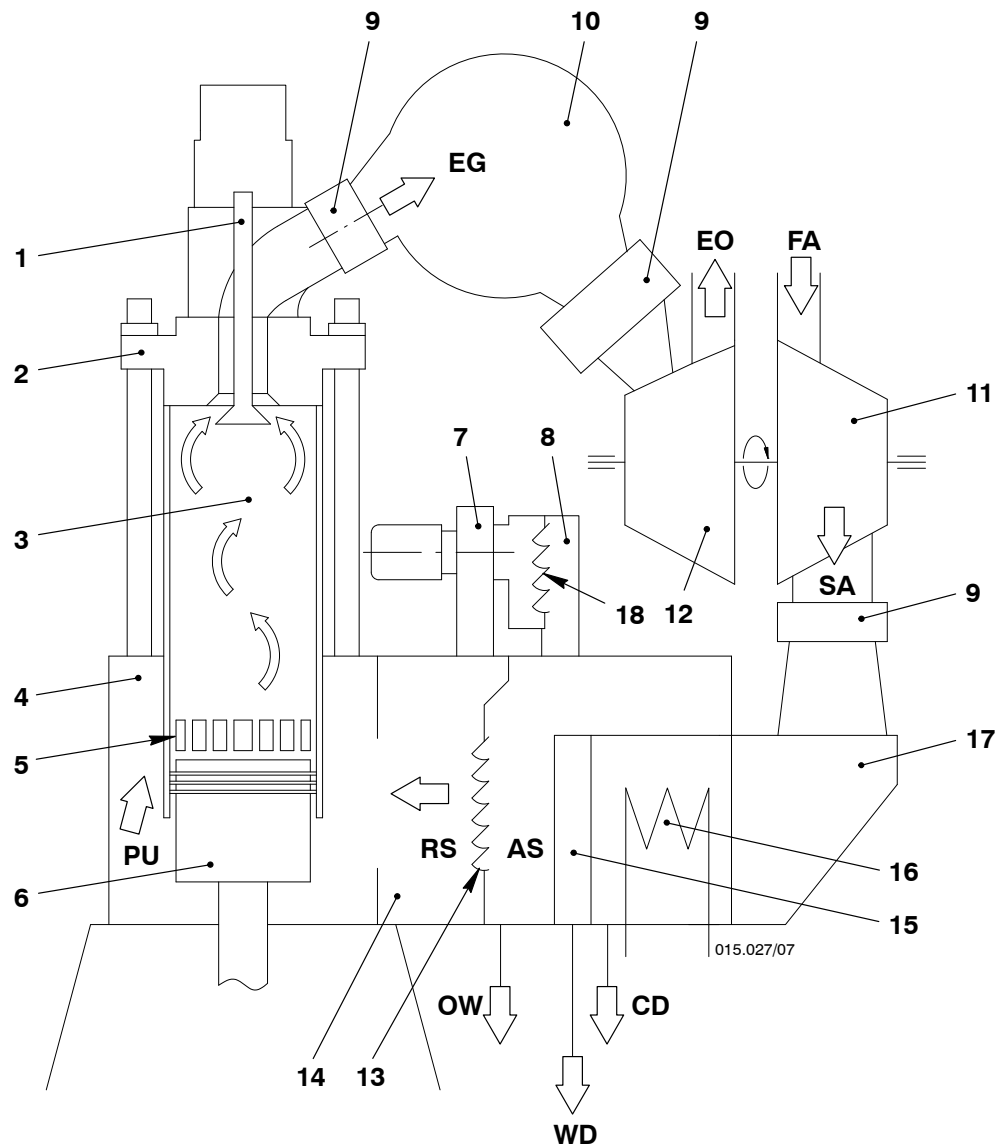
**Key:**

- | | |
|-------------------------|-------------------------------------------|
| 1 Exhaust valve | 16 Scavenge air cooler |
| 2 Cylinder cover | 17 Air duct |
| 3 Cylinder liner | 18 Air flaps before auxiliary blower |
| 4 Cylinder block | |
| 5 Inlet ports | |
| 6 Piston | EG Exhaust gas after cylinder |
| 7 Auxiliary blower | OW Oily-water drain |
| 8 Air inlet casing | EO Exhaust gas, outlet |
| 9 Expansion piece | FA Fresh air |
| 10 Exhaust gas manifold | PU Piston underside space |
| 11 Compressor | RS Receiver space |
| 12 Turbine | SA Scavenge air after blower (compressor) |
| 13 Air flaps | AS Air space |
| 14 Receiver | WD Water drain |
| 15 Water separator | CD Condensate from air cooler |

Cleaning the Turbocharger in Operation

Turbocharger TPL Type

Overview

1.	General	1/8
2.	Wash the compressor	1/8
3.	Wash the turbine	3/8
4.	Dry-clean procedure	6/8

1. General

The turbochargers have a system to clean the turbine and the compressor. It is possible to clean the turbine and the compressor while the turbocharger operates. Regular procedures to clean the turbine and the compressor prevent or decrease contamination and increase the time between overhauls. If the quantity of dirt becomes too much (scavenge air pressure decreases and exhaust gas temperature increases), the turbocharger must be disassembled and cleaned in accordance with the instructions given in the turbocharger manual (see Operating Data Sheet [0250-1](#) for the permitted pressure decrease).

Regular visual checks and procedures to clean the silencer are necessary to keep it in a serviceable condition. Clean the silencer and filter only when the engine is stopped and in accordance with the instructions given in the turbocharger manual.



Remark: One more filter mat installed on top of the silencer will keep the contamination on the air side to a minimum, but will cause a loss of pressure.

If there is an increase in pressure difference Δp (of 50% compared to the shop test value at the same engine load) or the filter mat is dirty (there is a difference in the color of the filter mat), clean the filter mat. See the instructions given in the turbocharger manual.

Use the methods that follow to regularly clean the compressor and turbine:

- Wash the compressor (wet clean)
- Wash the turbine (wet clean at decreased engine load)
- Dry clean the turbine (at full service load)

2. Wash the compressor (see Fig. 'A')

Intervals:

Wash the compressor at intervals of 24 operation hours.

Engine condition:

Wash the compressor when the engine is at the usual operation temperature and the load is as high as possible (full service load), i.e. at high turbocharger speed.

Cleaning the Turbocharger in Operation

Turbocharger TPL Type

2.1 Procedure

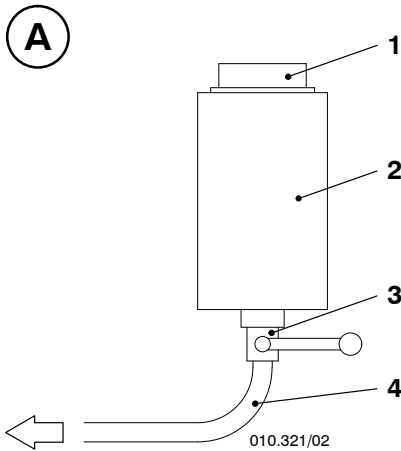

- ⇒ Open filler cap 1.
- ⇒ Fill the water container 2 with clean, fresh water (do not add cleaning agents).
 - The water quantity and the number of cleaning cycles is specified in the table below.
- ⇒ Close the filler cap 1 then open the shut-off valve 3 for approximately three minutes.
- ⇒ Close the shut-off valve 3. Make sure that the water container is empty.
 - An increase in scavenge air pressure, or a decrease in exhaust gas temperature shows that the procedure is successful.

Key to Illustration: 'A'

- 1 Filler cap
- 2 Water container
- 3 Shut-off valve
- 4 Water hose to compressor inlet

- ⇒ When the compressor is clean, operate the engine under load for a minimum of five minutes.



Remark: In dirty conditions, do the procedure again in accordance with the table below.

Should the cleaning remain unsuccessful, we recommend to check and overhaul the turbocharger by an authorized ABB service company.

Turbocharger Type	Water quantity [l]	Number of cleaning cycles Maximum
TPL 73	2	3
TPL 77	2	3

3. Wash the turbine (see Fig. 'B' to 'E')

Intervals:

Wash the turbine at intervals of between 50 to 500 operation hours

The interval is related to environmental effects on the intake air and the quantity of contamination in the turbocharger.

It is recommended that you clean the turbine regularly. At first every 100 running hours (e.g. one time each week). Adapt the intervals to the quantity of contamination found during turbocharger overhaul.

Conditions:

The engine power output must be decreased so that the exhaust gas temperature upstream of the turbine is within the limits given below:

Limits:

⇒ Make sure that the limits are as follows:

- The temperature upstream of the turbine must be less than 430°C.
- The scavenge air pressure must be between 0.3 bar and 0.6 bar before you clean the turbine.
- The water pressure must be 1 bar downstream of the ball cock 5 (Fig. 'C') during water injection.



Remark: We recommend that the turbine is washed at a scavenge air pressure of 0.4 bar (auxiliary blower in operation).

- Only use clean fresh water to clean the turbine. Do not use detergents or solvents.
- The water pressure must be a minimum of 2 bar.
- If a Selective Catalytic Reduction (SCR) installation is installed, stop the ammonia or urea injection before you clean the turbine.
- After you have cleaned the turbine, only start the injection when the exhaust temperature upstream of the turbine is more than 430°C.

Cleaning the Turbocharger in Operation

Turbocharger TPL Type

3.1 Procedure

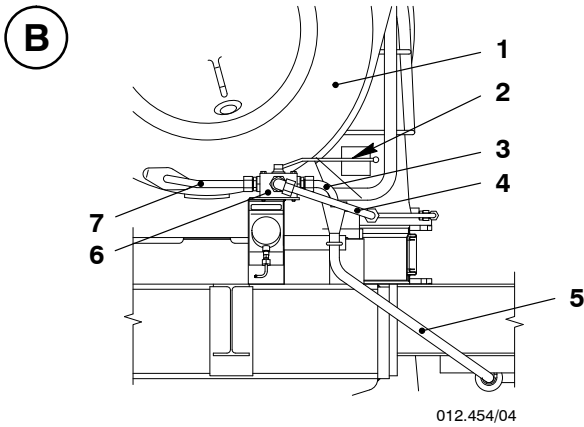

POSITION MARKS

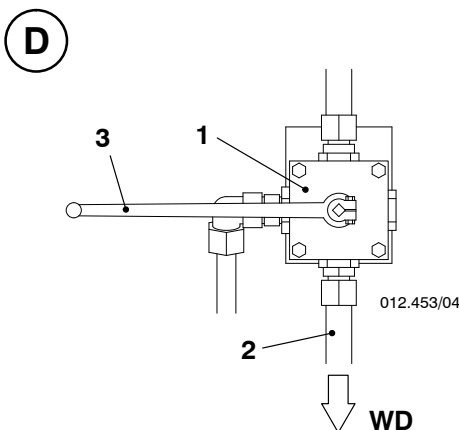
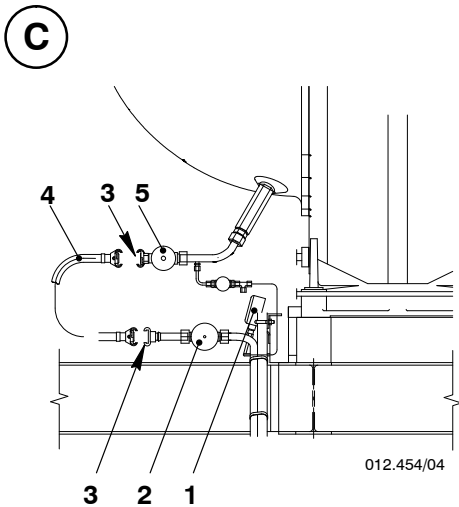
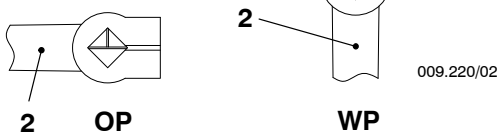

- ⇒ Turn the handle 2 of the ball cock 6 in the drain pipe 3 for the gas outlet casing 1 to the wash position 'WP' (see Fig. 'B'). The hose for scavenge air 4 closes at the same time. See the POSITION MARKS for the related positions. Exhaust gas will flow from the drain pipe 3 when the outlet is free.
- ⇒ Decrease the engine power to get the necessary scavenge air pressure.
- ⇒ Before you clean the turbine, operate the engine at a constant load for a minimum of five minutes.
- A fresh water supply must be available at the ball cock 6.

- ⇒ Connect the hose 4 to the claw couplings 3 (see Fig. 'C').
- ⇒ Open the ball cock 2.
- ⇒ Slowly open the ball cock 5 until the pressure gage 1 shows 1.0 bar. Let the water flow for 10 minutes.



Remark: Water will show after approximately two to three minutes. It is possible that no water will show.

- ⇒ Make sure that there is a decrease in the exhaust gas temperature (downstream of the turbocharger) and a decrease in turbocharger speed. This shows that there is sufficient water injection.
- ⇒ Close the ball cock 5.
- ⇒ Close the ball cock 2.
- ⇒ Disconnect and remove the hose 4 from the claw couplings 3.



Attention! In an emergency (e.g. for the safety of the ship), the engine load can be increased immediately during the wash procedure. The ball cock 5 must then be closed immediately to shut off the water supply.

- ⇒ When no water flows from the drain pipe 2 to the wash water drain 'WD' (see Fig. 'D'), turn the handle 3 of the ball cock 1 back to the operation position 'OP'. See the POSITION MARKS in Fig. 'B' for the related positions.



Remark: Operate the engine for a minimum of 10 minutes above 25% load to make sure that the exhaust gas installation is completely dry.

If the exhaust gas temperature downstream of the turbine is still too high at the higher loads, do the wash procedure again.

If the exhaust gas temperature downstream of the turbine is still not correct after three wash procedures, see the instructions in the turbocharger manual to disassemble and clean the turbocharger.

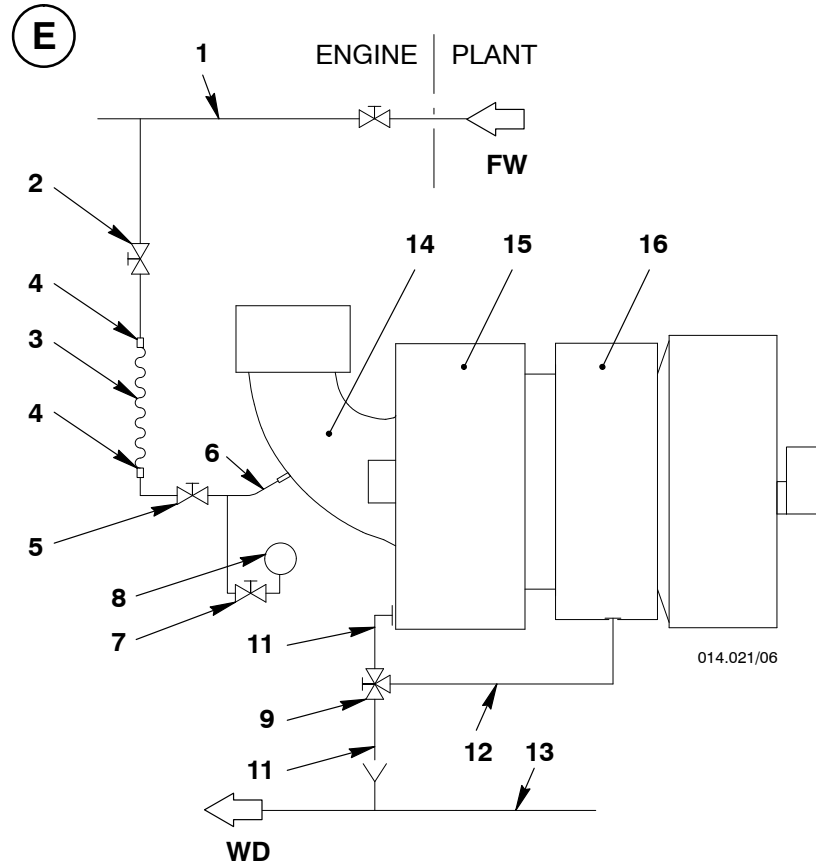

Key to Illustrations:

'E' Schematic diagram of turbocharger cleaning

- 1 Fresh water supply pipe
- 2 Ball cock
- 3 Hose
- 4 Claw coupling
- 5 Ball cock
- 6 Water connection hose
- 7 Shut-off valve
- 8 Pressure gage
- 9 Ball cock
- 10 Ball cock handle

- 11 Drain pipe
- 12 Hose for scavenge air
- 13 Drain pipe with funnel
- 14 Gas inlet casing
- 15 Gas outlet casing
- 16 Air outlet casing

FW Fresh water
WD Wash-water drain

4. Dry-clean procedure

Dry solid particles (granules) are used for the dry-clean procedure. The quantity of granules used is related to the turbocharger size. During the dry clean procedure, compressed air blows the granules into the exhaust pipe upstream of the turbocharger.

The granules have a mechanical effect that removes dirt particles on the nozzle ring and turbine blades. It is not possible to remove thick dirt particles with the small quantity of granules necessary for each dry-clean procedure. Thus, frequent use of this method is necessary.

The hot exhaust temperature burns the granules. The exhaust flow removes the burnt granules and the dirt particles from the turbocharger.

This method is satisfactory at exhaust gas temperatures of more than 500°C upstream of the turbocharger.

4.1 Dry-clean the turbine (see Fig. 'F' to 'G')

Intervals:

Dry-clean the turbine at intervals of between 24 to 48 operation hours.

The intervals are related to environmental effects on the intake air and the quantity of contamination of the turbocharger.

Conditions:

Do the procedure when the engine is at the usual operation temperature and the load is as high as possible (full service load), i.e. at high turbocharger speed.

Limits:

The scavenge air pressure must be more than 0.5 bar.

The specified quantity of granules for the related turbocharger type is shown in the table that follows:

Turbocharger Type	Quantity [l]
TPL 73	1.0
TPL 77	1.5

4.2 Granulate specification

Materials:	Hard, granulated materials, such as natural core granulates, soft-blast media or active charcoal particles.
Mean grain size:	1.2 mm to 2.0 mm
Density:	maximum 2.0 kg/dm ³
Storage:	Clean and dry area
Suppliers:	See manual of the turbocharger manufacturer

4.3 Procedure

(F)

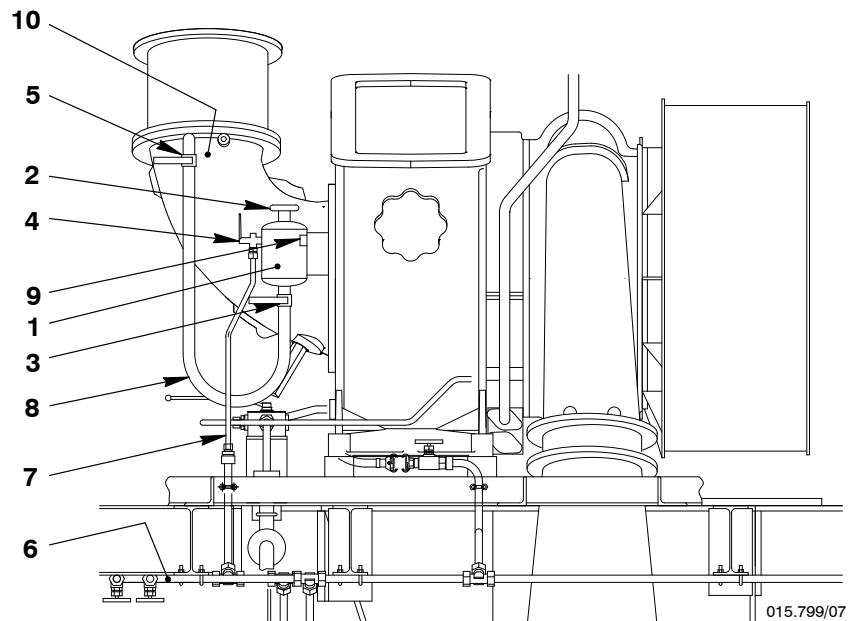

Key to Illustrations: 'F' Location of dry-clean plant

- | | |
|-----------------------------------------|------------------------------|
| 1 Pressure vessel | 6 Compressed air supply |
| 2 Cover | 7 Compressed air supply pipe |
| 3 Shut-off valve | 8 Hose line |
| 4 3-way valve (compressed air and vent) | 9 Relief valve |
| 5 Shut-off valve | 10 Gas inlet casing |

Cleaning the Turbocharger in Operation

Turbocharger TPL Type



Remark: Before you do this procedure, use compressed air to blow through the plant to remove particles or condensate that can collect in the pipes.

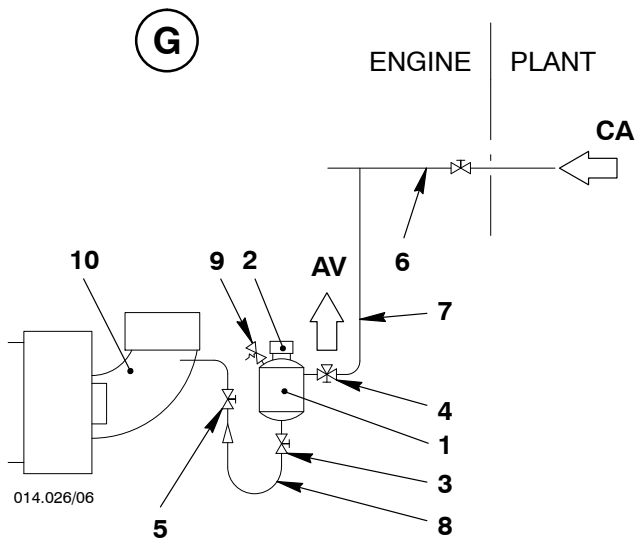

Initial position – engine in usual operation (no procedure to clean)

- The 3-way valve 4 is in the position VESSEL VENTING (see Fig. 'G').
- The shut-off valves 3 and 5 are closed.
- Pressure vessel 1 is empty and the cover 2 is attached.
- Compressed air 'CA' is available at the 3-way valve 4.

CHECK

Make sure that the shut-off valve 3 is closed and air in the pressure vessel 1 is released through the 3-way valve 4.

- ⇒ Carefully loosen the cover 2 to release possible pressure from the pressure vessel 1.
- ⇒ Fill the pressure vessel 1 with the applicable quantity of granules (see the table above).
- ⇒ Attach the cover 2 to the pressure vessel 1.
- ⇒ Open the 3-way valve 4 (the air vent 'AV' closes and compressed air 'CA' flows to the pressure vessel 1).
- ⇒ Open the shut-off valve 5, then open the shut-off valve 3. Compressed air blows the granules into the gas inlet casing 10.
- ⇒ After approximately three to four minutes, close the shut-off valve 3, then close the shut-off valve 5 (the procedure is completed).
- ⇒ Close the 3-way valve 4 (the air vent 'AV' opens and the flow of compressed air to the pressure vessel 1 stops).



Attention! It is possible that soot particles that are not fully burned are released through the chimney.



Remark: If the mean exhaust gas temperature downstream of the turbine continues to be too high at higher loads, do the procedure again.

If the procedure is not successful (after you have done the procedure three times) and the exhaust gas temperature downstream of the turbine is still unsatisfactory, the turbocharger must be disassembled and cleaned. See the instructions in the turbocharger manual.

Cleaning the Turbocharger in Operation

Turbocharger MET Type

Overview

1. General	1/5
2. Wash the compressor	1/5
3. Dry-clean procedure	3/5

1. General

The turbochargers have a system to clean the compressor and turbine. It is possible to clean the compressor and the turbine while the turbocharger operates. Regular procedures to clean the turbine and the compressor prevent or decrease contamination and increase the time between overhauls. If the quantity of contamination becomes too much, (i.e. the scavenge air pressure decreases and exhaust gas temperatures increase), the turbocharger must be disassembled and cleaned in accordance with the instructions given in the turbocharger manual (see the Operating Data Sheet 0250-1 for the permitted pressure decrease).

Regular visual checks and procedures to clean the silencer are necessary to keep it in a serviceable condition. Clean the silencer and filter only when the engine is stopped and in accordance with the instructions given in the turbocharger manual.



Remark: One more filter mats installed on top of the silencer will keep the contamination on the air side to a minimum, but will cause a loss of pressure.

If there is an increase of the pressure difference (Δp) to maximum 10 mbar, or the filter mat is dirty (there is a difference in the color of the filter mat), clean the filter mat. See the instructions given in the turbocharger manual.

Use the methods that follow to regularly clean the turbocharger:

- Wash the compressor (wet clean)
- Dry-clean the turbine (at full service load).

2. Wash the compressor (see Fig. 'A')

Intervals:

Wash the compressor at intervals of approximately 100 operating hours.

The interval is related to the environmental effects on the intake air and the quantity of contamination in the turbocharger.

Engine condition:

The procedure to clean the turbocharger must be done at decreased engine power (less than 50% load), i.e. at lower turbocharger speed as shown in the table that follows:

Turbocharger		Water quantity [l]	Time [Sec.]
Type	Speed [rpm]		
MET 53MB MET 53MB (II)	Approx. 7000 to 9500	2.0	Approx. 40 to 80
MET 66MB MET 66MB (II)	Approx. 5500 to 7500	2.5	Approx. 50 to 100
MET 60 MB	Approx. 6300 to 8500	2.25	Approx. 45 to 90
MET 71MB	Approx. 5000 to 7000	2.75	Approx. 55 to 110

2.1 Procedure

- ⇒ Decrease engine power to get the applicable turbocharger speed (see the table above).
- ⇒ Before you do this procedure, operate the engine at a constant load for a minimum of five minutes.
- ⇒ See the table above for the specified rpm, water quantities and time for the related turbocharger.

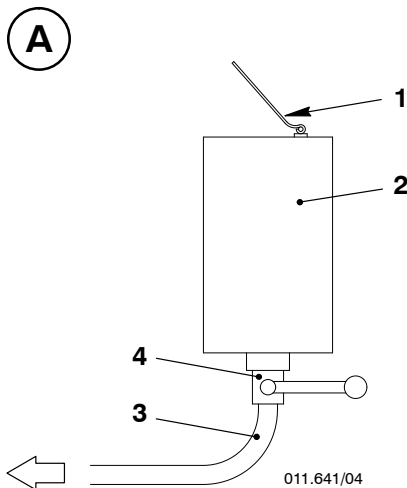

- ⇒ Make sure that the filter in the water container 2 is not clogged (see Fig. 'A').
- ⇒ Open the hinged cover 1.
- ⇒ Fill the water container 2 with clean fresh water (do not add cleaning agents).
- ⇒ Close the hinged cover 1.
- ⇒ Open the shut-off valve 4 for the specified time.
 - The water flows through the hose 3 to the compressor inlet.
- ⇒ Close the shut-off valve 4.
- ⇒ Do a check to make sure that the water container 2 is empty.
 - An increase in scavenge air pressure, or a decrease in exhaust gas temperature shows that the procedure is satisfactory.

- ⇒ When the compressor is clean, operate the engine at load for a minimum of five minutes.

3. Dry-clean procedure

Dry solid particles (granules) are used for the dry-clean procedure. The quantity of granules used is related to the turbocharger size. During the procedure, compressed air blows the granules into the exhaust pipe upstream of the turbocharger.

The granules have a mechanical effect that removes dirt particles on the nozzle ring and turbine blades. It is not possible to remove thick dirt particles with the small quantity of granules necessary for each dry-clean procedure. Thus, frequent use of this method is necessary.

This method is satisfactory at exhaust gas temperatures of more than 500°C upstream of the turbocharger.

The hot exhaust temperature burns the granules. The burned granules and contamination are removed from the turbocharger.

3.1 Dry-clean the turbine (see Fig. 'B' and Fig. 'C')

Intervals:

Dry-clean the turbine at intervals of 100 operation hours.

The intervals are related to environmental effects on the intake air and the quantity of contamination in the turbocharger.

Regular dry cleaning in service is recommended initially every 100 running hours (e.g. one time each week). Adapt the cleaning intervals to the quantity of contamination found during turbocharger overhaul.

Conditions:

Do the procedure when the engine is at the usual operation temperature and the load is as high as possible (full service load), i.e. at high turbocharger speed.

Limits:

The scavenge air pressure must be more than 0.5 bar.

The maximum turbocharger speed and specified quantity of granules for the related turbocharger type is shown in the table that follows:

Turbocharger		Quantity [l]
Type	Speed [rpm]	
MET 53MB MET 53MB (II)	Max. 14 800	1.6
MET 66MB MET 66MB (II)	Max. 11 900	2.6
MET 60MB	Max. 13 300	2.1
MET 71MB	Max. 11 000	3.0

3.2 Granule specification

Materials:

Hard materials, such as milled walnut shell or grain (rice, wheat etc.)

Mean corn size:

2.0 to 2.8 mm (grain diameter less than 3 mm)

Storage:

Clean and dry area

Suppliers:

See the turbocharger manual.

Cleaning the Turbocharger in Operation

Turbocharger MET Type

3.3 Procedure

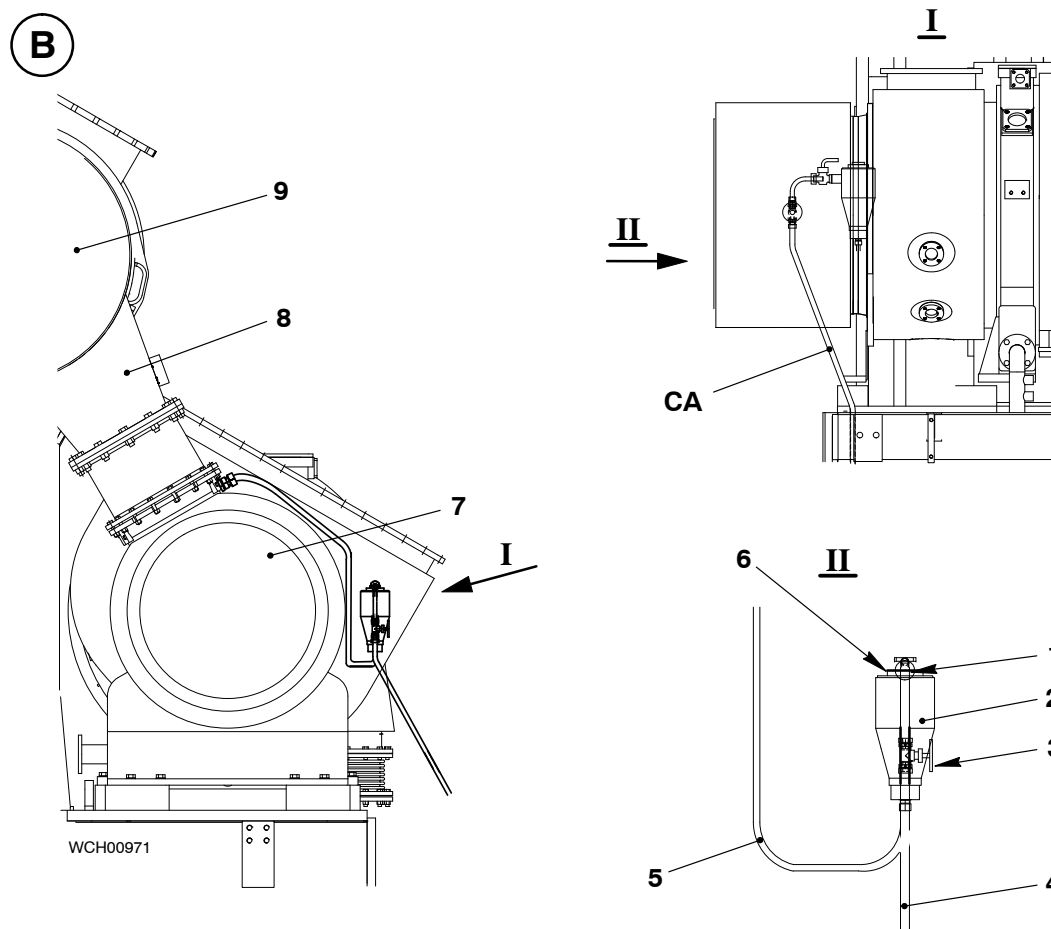
**Key to Illustrations: 'B' Location of device**

- | | |
|-------------------------|-----------------------------------------|
| 1 Shut-off valve | 7 Exhaust gas manifold |
| 2 Pressure vessel | 8 Exhaust pipe upstream of turbocharger |
| 3 Shut-off valve | 9 Gas inlet casing |
| 4 Compressed air supply | |
| 5 Pipe (to turbine) | |
| 6 Filler cap | CA Compressed air |

Cleaning the Turbocharger in Operation

Turbocharger MET Type



Remark: Before you do this procedure, use compressed air to blow through the plant. This cools the plant and removes particles and condensation that can collect in the pipes.

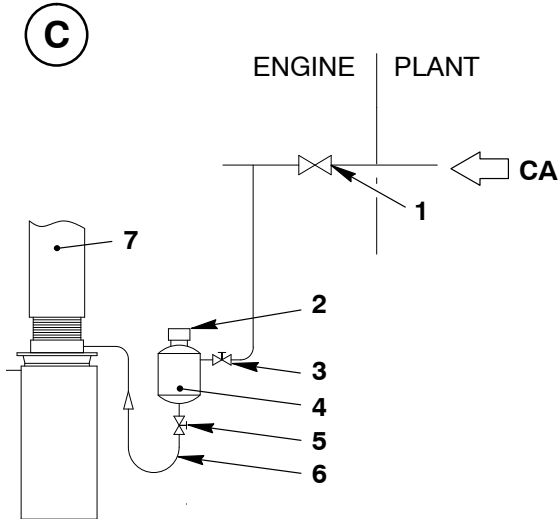

011.657/04

Initial position – engine in usual operation (no procedure to clean).

⇒ Make sure that:

- The shut-off valves 3 and 5 are closed (see Fig. 'C').
- The pressure vessel 4 is empty and the filler cap 2 is closed.
- The shut-off valve 1 is open and compressed air 'CA' is available at the shut-off valve 4.

Prepare as follows:

- ⇒ Open the shut-off valves 3 and 5.
- ⇒ After approximately two minutes, close the shut-off valves 3 and 5 (blow-through is completed).

- ⇒ Carefully loosen the filler cap 2 to release possible pressure from the pressure vessel 1.
- ⇒ Remove the filler cap 2 from the pressure vessel 4.
- ⇒ Fill the pressure vessel 4 with the specified quantity of granules.
- ⇒ Install the filler cap 2 to the pressure vessel 4.
- ⇒ Open the shut-off valves 3 and 5.
- Compressed air blows the granules into the exhaust pipe 7.
- ⇒ After approximately two minutes, close the shut-off valves 3 and 5 (the procedure is completed).



Attention! It is possible that soot particles that are not fully burned are released through the chimney.

If the engine performance changes suddenly when the granules are put in, use half the quantity given in the table above.



Remark: If the mean exhaust gas temperature downstream of the turbine is still too high at higher loads, do the procedure again.

If the procedure is not successful (after you have done the procedure three times) and the exhaust gas temperature downstream of the turbine is still unsatisfactory, the turbocharger must be disassembled and cleaned. See the instructions in the turbocharger manual.

Intentionally blank

Cleaning the Turbocharger in Operation

Turbocharger A100-L Type

Overview

1.	General	1/6
2.	Wash the compressor	1/6
3.	Dry-clean the turbine	4/6

1. General

The turbochargers have a system to clean the compressor and turbine. It is possible to clean the compressor and the turbine while the turbocharger operates. Regular procedures to clean the turbine and the compressor prevent or decrease contamination and increase the time between overhauls. If the quantity of contamination becomes too much, (i.e. the scavenge air pressure decreases and exhaust gas temperatures increase), the turbocharger must be disassembled and cleaned in accordance with the instructions given in the turbocharger manual (see the Operating Data Sheet 0250-1 for the permitted pressure decrease).

Regular visual checks and procedures to clean the silencer are necessary to keep it in a serviceable condition. Clean the silencer and filter only when the engine is stopped and in accordance with the instructions given in the turbocharger manual.



Remark: One more filter mats installed on top of the silencer will keep the contamination on the air side to a minimum, but will cause a loss of pressure.

If there is an increase of the pressure difference Δp (of 50% compared to shop test value at same engine load) or the filter mat is dirty (there is a difference in the color of the filter mat), clean the filter mat. See the instructions given in the turbocharger manual.

Use the methods that follow to regularly clean the turbocharger:

- Wash the compressor (wet clean)
- Dry-clean the turbine (at full service load).

2. Wash the compressor (see Fig. 'A')

Intervals:

Wash the compressor at intervals of 24 operation hours.

Conditions:

Do the procedure when the engine is at the usual operation temperature and the load is as high as possible (full service load), i.e. at high turbocharger speed.

Cleaning the Turbocharger in Operation

Turbocharger A100-L Type

2.1 Procedure

- ⇒ Remove the insulation at the flange of the filter silencer 4 (if installed).
- ⇒ Remove the filler cap 1 from the filler opening 2.
- ⇒ Fill a water container 3 with clean fresh water (do not add cleaning agents).
- The water quantity is specified in the table below:

Turbocharger Type	Water quantity [l]	Number of cycles Maximum
A165-L	2.0	3
A170-L	2.0	3
A175-L	3.0	3
A180-L	3.0	3

- ⇒ Carefully put the water into the filler opening 2.



Remark: The necessary time period to put the water into the filler opening is between 4 seconds and 15 seconds.

- ⇒ Make sure that all the water has gone.
- ⇒ Put the lock 1 on filler opening 2, then tighten the lock with your hand.
- ⇒ Install the insulation to the flange of the filter silencer 4 (if removed before).
- An increase in scavenge air pressure, or a decrease in exhaust gas temperature shows that the procedure is satisfactory.

A

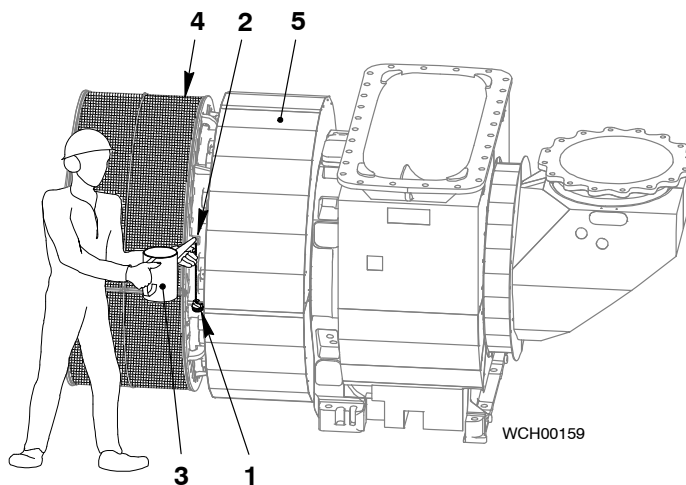

Key to Illustration: 'A'

- 1 Lock
- 2 Filler opening
- 3 Can
- 4 Filter silencer
- 5 Air outlet casing

- When the compressor is clean, operate the engine at load for a minimum of five minutes.



Remark: In dirty operating conditions the procedure can be done again. See the table above for the maximum number of cycles.

If the procedure is not successful (after you have done the procedure three times), we recommend that an authorized ABB service company does an overhaul of the turbocharger.

2.2 Filter plug

If you can see water in the filler opening after 20 seconds, do the procedure that follows:

- ⇒ Use a box spanner (AF24) to remove the filter plug 1 from the air outlet casing 3 (see Fig. 'B').
- ⇒ Clean the holes in the filter plug 1.
- ⇒ Put the filter plug in position in the air outlet casing 3.
- ⇒ Torque the filler plug 1 to 45 Nm.

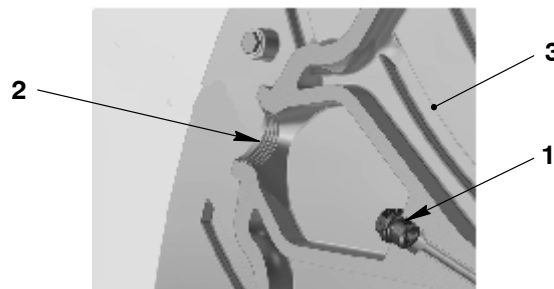
B

WCH00160

Key to Illustration: 'B'

- 1 Filter plug
- 2 Filler opening
- 3 Air outlet casing

3. Dry-clean procedure

Dry solid particles (granules) are used for the dry cleaning procedure. The quantity of granules used is related to the turbocharger size. During the procedure, compressed air blows the granules into the exhaust pipe upstream of the turbocharger.

The granules have a mechanical effect that removes dirt particles on the nozzle ring and turbine blades. It is not possible to remove thick dirt particles with the small quantity of granules necessary for each dry-clean procedure. Thus, frequent use of this method is necessary.

This method is satisfactory at exhaust gas temperatures of more than 500°C upstream of the turbocharger.

The hot exhaust temperature burns the granules. The burned granules and contamination are removed from the turbocharger.

3.1 Dry-clean the turbine (see Fig. 'C' to 'E')

Intervals:

Dry-clean the turbine at intervals of approximately 50 operation hours.

The intervals are related to environmental effects on the intake air and the quantity of contamination in the turbocharger.

Conditions:

Do the procedure when the engine is at an engine load of between 25% to 85%.

Limits:

The scavenge air pressure must be more than 0.5 bar.

The specified quantity of granules for the related turbocharger type is shown in the table that follows:

Turbocharger Type	Quantity [l]
A165-L	1.0
A170-L	1.5
A175-L	2.0
A180-L	2.5

3.2 Granulate specification

Materials:	Hard, granulated materials, such as natural core granulates, soft-blast media or active charcoal particles.
Mean grain size:	1.2 to 2.0 mm
Density:	max. 1.2 kg/dm ³
Storage:	Clean and dry area
Suppliers:	See the documents of the turbocharger manufacturer

3.3 Procedure

C

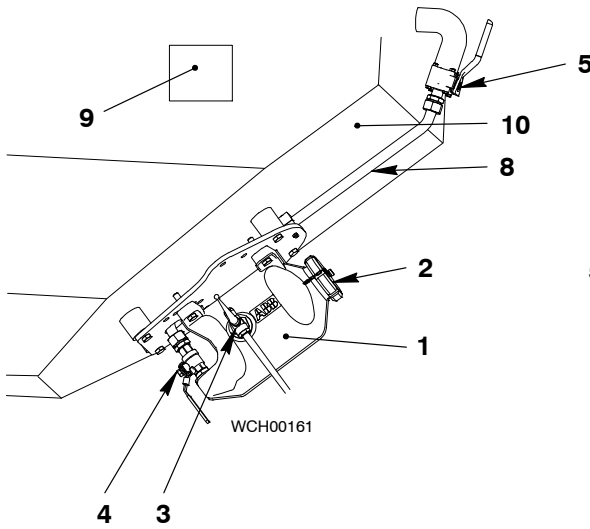

D

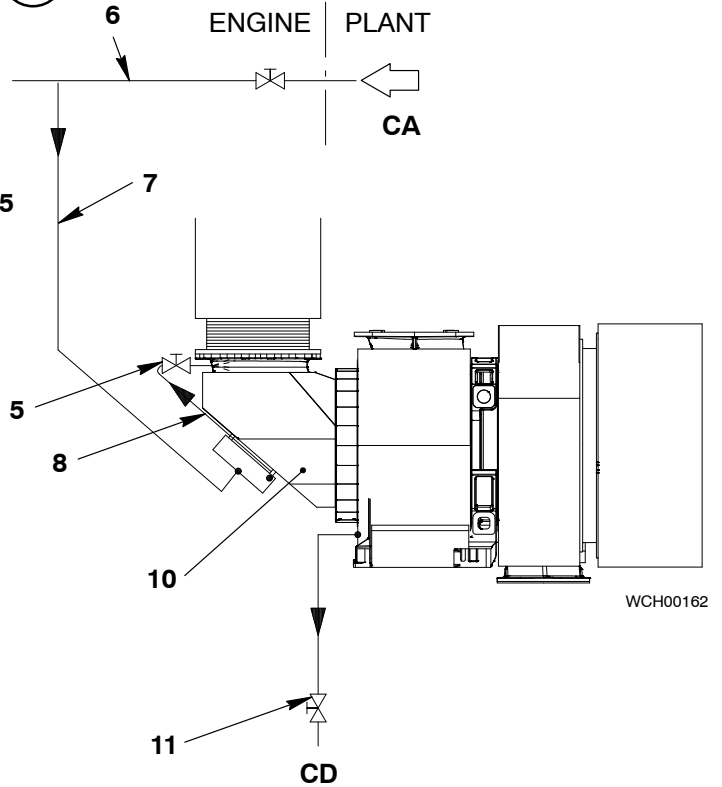

Key to Illustrations: 'C' Location of dry-clean device
 'D' Schematic diagram of dry-clean plant

- | | |
|-----------------------------------------|---------------------|
| 1 Container | 9 Instructions |
| 2 Filler cap | 10 Gas inlet casing |
| 3 3-way valve (compressed air/air vent) | 11 Ball valve |
| 4 On-off valve | |
| 5 Protection valve | CA Compressed air |
| 6 Compressed air supply | AV Vent |
| 7 Compressed air supply pipe | CD Condensate drain |
| 8 Pipe | |

Cleaning the Turbocharger in Operation

Turbocharger A100-L Type



Remark: Before you do this procedure, use compressed air to blow through the plant. This cools the plant and removes particles and condensation that can collect in the pipes.

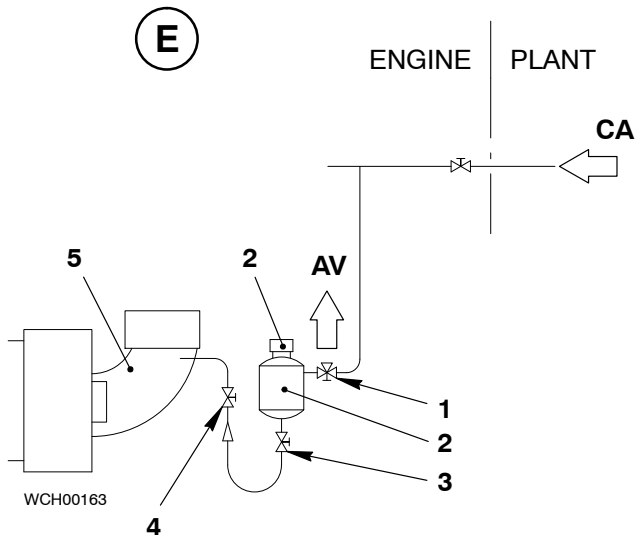

CA Initial position, engine in usual operation (no procedure to clean).

⇒ Make sure that:

- The 3-way valve 1 is in position VENTING position (see Fig. 'E').
- The on-off valve 3 is closed.
- The protection valve 4 is closed.
- The container 2 is empty.
- The filler cap 8 is installed.
- Compressed air 'CA' must be available at the 3-way valve 1.

⇒ Open ball valve 11 (see Fig. 'D') to drain the condensate.

⇒ Close the ball valve 11.

⇒ Open the 3-way valve 3 to release air from the container 2 (see Fig. 'E').

⇒ Carefully loosen the filler cap 8 to release possible pressure from the container 2.

⇒ Fill the container 2 with the specified quantity of granules.

⇒ Install the filler cap 8 to the container 2.

⇒ Open the 3-way valve 1 (the air vent 'AV' closes and compressed air 'CA' flows to the container 2).

⇒ Open the on-off valve 3.

⇒ Open the protection valve 4. Compressed air blows the granules into the gas inlet casing 5.

⇒ After approximately three to four minutes, close the on-off valve 3, then close the protection valve 4 (the procedure is completed).

⇒ Close the 3-way valve 1 (the air vent 'AV' opens and the flow of compressed air to the container 2 stops).



Attention! It is possible that soot particles that are not fully burned are released through the chimney.



Remark: If the mean exhaust gas temperature downstream of the turbine is still too high at higher loads, do the procedure again.

If the procedure is not successful (after you have done the procedure three times), we recommend that an authorized ABB service company does an overhaul of the turbocharger.

Auxiliary Blower and Switch Box

1. Auxiliary blower

Electric motors 6 operate the auxiliary blowers 5, which are installed on the scavenge air receiver 3. The auxiliary blowers supply air from the air space through suction casing into the receiver space during the start and operation at low load. Air flaps prevent the back-flow of air into the receiver (see 6420-1 Scavenge Air Cooler).

A

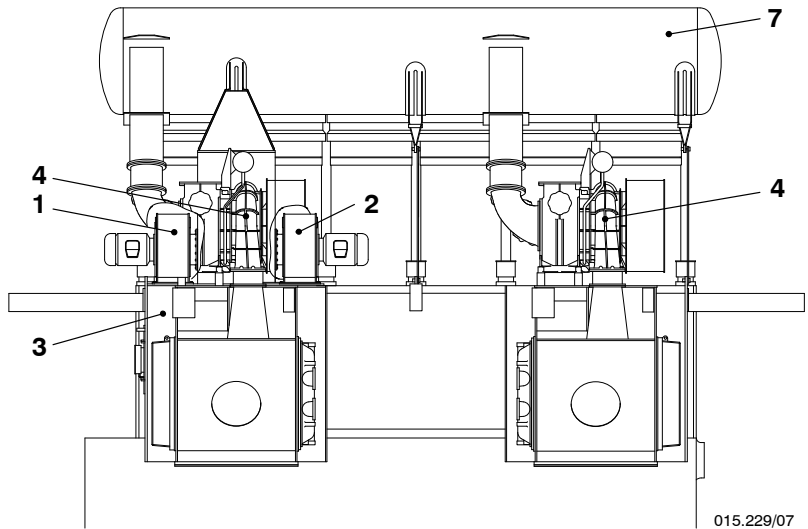

015.229/07

B

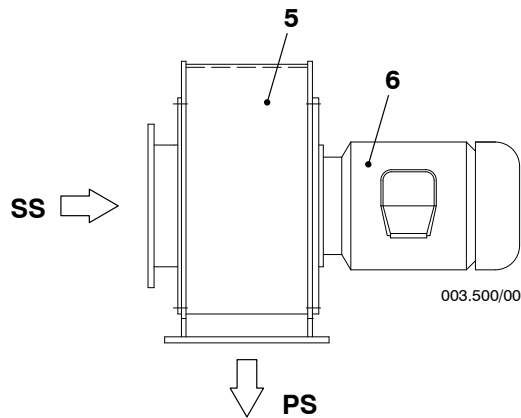

Key to Illustrations: 'A' Location of auxiliary blower
'B' Auxiliary blower

- | | |
|--------------------------------------|--------------------|
| 1 Auxiliary blower left hand design | 5 Blower |
| 2 Auxiliary blower right hand design | 6 Electric motor |
| 3 Scavenge air receiver | 7 Exhaust manifold |
| 4 Turbocharger | |
| | PS Pressure side |
| | SS Suction side |

Auxiliary Blower and Switch Box

2. Switch box

2.1 General

The engine builder supplies an electrical switch box 1 for each auxiliary blower.

2.2 Function

During the engine start procedure, the first auxiliary blower starts immediately. After approximately 2 to 3 seconds, the other auxiliary blower starts.

When the turbocharger gives sufficient pressure in the receiver, the auxiliary blowers stop.

If the scavenge air pressure decreases below the minimum pressure, the auxiliary blowers operate as given above (for more data, see 4003-1 'Auxiliary Blower').

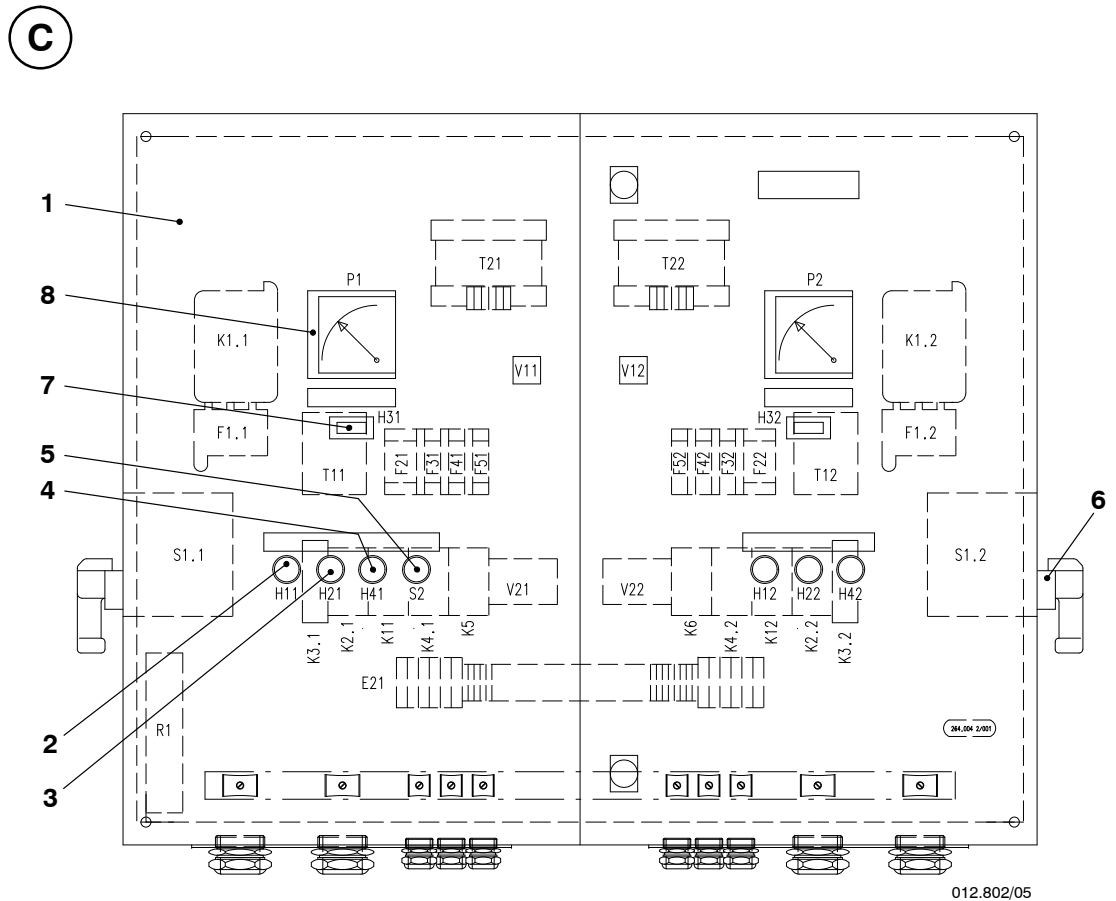

Key to Illustration: 'C' Switch box (example)

- | | |
|----------------------|----------------|
| 1 Switch box | 5 Lamp test |
| 2 Voltage indicator | 6 Main switch |
| 3 Service indicator | 7 Hour counter |
| 4 Overload indicator | 8 Ampere meter |

Scavenge Air Cooler

Operating Instructions and Cleaning

1. General

A Scavenge Air Cooler (SAC) is installed downstream of the turbocharger. The SAC decreases the temperature of the compressed / heated air that flows from the turbocharger. The standard cooler is a single-stage multi-pass cooler. The water flows through the cooler in the opposite direction of the air flow more than one time. The cool water enters the cooler at 'CI', flows through in different directions and leaves at 'CO' (see Fig. 'A'). The temperature difference of the water and scavenge air is thus applied equally along all of the SAC.

2. Operating instructions

If air collects in the cooling water system of the SAC, problems for the engine and the SAC can occur. Thus, the SAC must operate correctly.

You must do regular checks of the SAC temperature. See the data in [0250-2](#) Operating Data Sheet.

If the level switch 19 of the float / solenoid switch unit 17 activates an alarm during operation, the cause (condensate water or SAC cooling water) must be found. If the cause is SAC cooling water, the SAC must be disassembled and repaired (see the Maintenance Manual 6606-2).

To prevent damage to the SAC, the cooling water must flow correctly during operation. The cooling water flow must not be decreased at partial load, or during maneuvering.



Remark: Do not use the butterfly valves at the cooling water inlet and outlet pipes to control the flow rate. The water separators (which are plastic) could be damaged because the scavenge air temperatures are too high at higher loads.

For data about operation with a defective SAC, see [0550-1](#) paragraph 1.

When the SAC operates correctly, record the temperature difference between the scavenge air outlet and the cooling water inlet. Use the temperature difference as a guide. You must do regular checks of the two temperature values and compare them with the temperatures you recorded.

If the temperature difference increases and the engine load and cooling water flow do not change, the SAC is dirty.

If the water side of the SAC is dirty, the scavenge air temperature increases.

If the air side of the SAC is dirty, the pressure difference (Δp) of the scavenge air through the SAC increases. This does not show the full effect of the dirt because an increased resistance also causes a decreased air flow from the turbocharger. For more data about the SAC during operation, see [0250-1](#) Operating Data Sheet.

Higher scavenge air temperature and decreased air flow cause increased thermal load of the engine and higher exhaust gas temperatures.

You can clean the air side of the SAC during engine operation.

You can clean the water side of the SAC only when the engine has stopped. For data to clean the water side of the SAC, see the Maintenance Manual 6606-1.

Operating Instructions and Cleaning

A

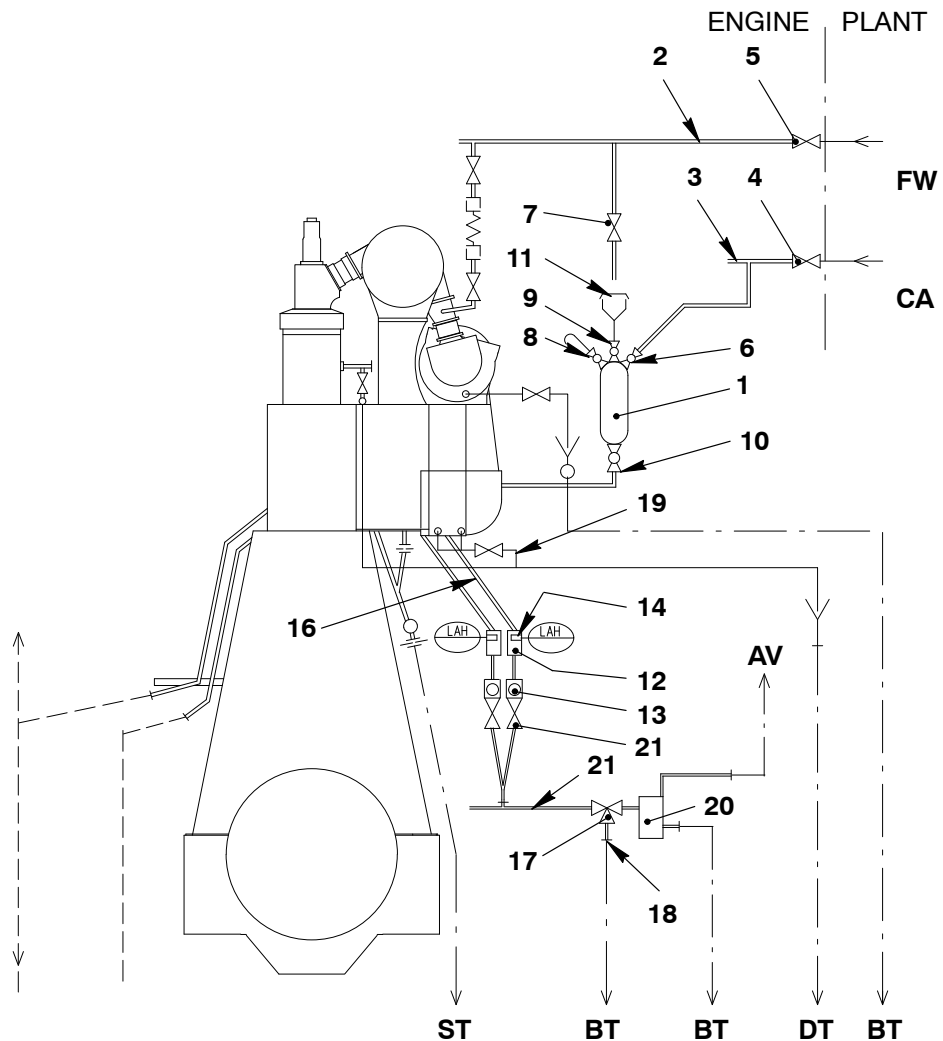
**Key to Illustrations: 'A' Location of wash system parts on the engine**

- | | |
|---------------------------------------|-----------------------------------------------|
| 1 Container | 16 Condensate / wash-water drain pipe |
| 2 Fresh water supply pipe | 17 3-way ball valve |
| 3 Compressed air supply pipe | 18 Cleaning fluid / wash-water drain |
| 4 Ball valve | 19 SAC drain |
| 5 Ball valve | 20 Venting unit |
| 6 Shut-off valve | 21 Condensate and dirty water collection pipe |
| 7 Shut-off valve | CA Compressed air from board system 7–8 bar |
| 8 Shut-off valve (vent) | AV Air vent |
| 9 Ball cock | FW Fresh water 2.5 bar |
| 10 Ball cock | CO Cooling water outlet |
| 11 Funnel | CI Cooling water inlet |
| 12 Float / solenoid switch unit | ST Drain to sludge water tank (oleiferous) |
| 13 Sight glass | DT Drain to water drain tank |
| 14 Level switch | BT Drain to bilge water tank |
| 15 Butterfly valve with orifice plate | |

Operating Instructions and Cleaning

3. SAC air side – clean during operation

The equipment necessary to clean the air side of the SAC is installed on the engine.

3.1 Intervals

Initially, we recommend that you clean the SAC weekly. If there is no change in the pressure difference (Δp) through the SAC, the interval can be increased (e.g. monthly).

The pressure difference must not be more than the maximum limit (Δp increase of 50% compared to the shop test value at the same engine load). For more data, see the Maintenance Manual 0380-1).

The quantity of contamination in the SAC is related to the condition of the air intake and the maintenance of the air suction filter on the turbocharger.



Remark: We recommend that you do not clean the SAC in tropical conditions because of increased condensation.

3.2 Procedure

Clean the SAC while the engine operates at partial load, i.e. below 50% load (see also the instruction panel on the engine). The air temperature downstream of the compressor (turbocharger) must not be more than 100°C. This is because heat will change too much of the cleaning agent to a gas.

Operating Instructions and Cleaning

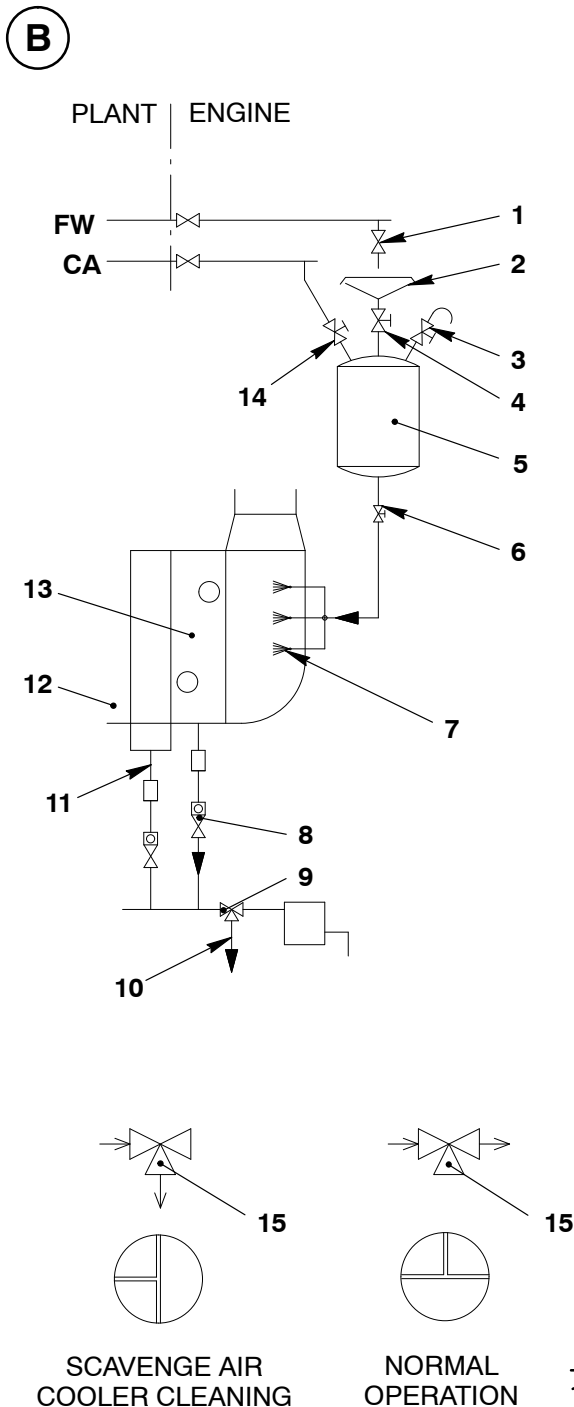

- ⇒ Decrease the engine power to the values given before.
- ⇒ Make sure that compressed air and fresh water are available at the shut-off valves 14 and 1 (see Fig. 'B').
- ⇒ Open the shut-off valve 3 to release possible pressure in the container 5.
- ⇒ Open the ball cock 4.
- ⇒ Open the shut-off valve 1 sufficiently to prevent back-flow of water into the funnel 2.
- ⇒ Fill the container 5 with fresh water 'FW' (20 liters).
- ⇒ Add the specified quantity of cleaning fluid into the container 1 through the funnel 2 (see paragraph 3.3 Cleaning fluid).
- ⇒ Close the ball cock 4 and the shut-off valve 3.
- ⇒ Open the shut-off valve 14 to let compressed air 'CA' flow into the container 5.
- ⇒ Open the ball cock 6 on the container 5. The water/cleaning fluid is sprayed through the nozzles 7 in approximately one minute.
- ⇒ Open the butterfly valve 8 on the two drain pipes 11.
- ⇒ Move the 3-way ball valve 15 to SCAVENGE AIR COOLER CLEANING. The water/cleaning fluid goes through the drain 10.
- ⇒ Close the shut-off valve 14 and the ball cock 6.
- ⇒ Open the shut-off valve 3 until there is no pressure in the container 5.
- ⇒ Close the two butterfly valves 8.
- ⇒ Move the 3-way ball valve 15 to NORMAL OPERATION.
- ⇒ After 10 minutes, do the procedure again with fresh water only (no cleaning fluid). The procedure is completed.



Remark: You can also use a hand-held container filled with cleaning fluid mixed with fresh water to put into the funnel 2. When you use this method, make sure that the shut-off valve 1 stays closed.



Remark: Dirt particles that are loosened from the cooling fins can collect in the water separator or the scavenge air receiver 12. Do a check of the cooling fins and clean if necessary (see the Maintenance Manual).

Operating Instructions and Cleaning

3.3 Cleaning fluid

Use cleaning fluids only from recommended suppliers. You must follow the instructions in the supplier documentation for the applicable water/cleaning fluid ratios.

For in-service cleaning, use only those fluids that have a sufficiently high flash point.



Remark: Data about operation, maintenance and repair of SAC are given in the Instruction Leaflets from the engine manufacturer or supplier.

You can get these Instruction Leaflets directly from the manufacturers. It is also possible to send an order for Instruction Leaflets from the engine manufacturer or supplier.

When you send an order for Instruction Leaflets, you must give the data that follows:

- The engine type and Number
- The engine supplier
- The SAC manufacturer and type
- The necessary language.

Intentionally blank

Cylinder Lubrication

Group 7

Cylinder Lubrication	7218-1/A2
Instructions Concerning Measurement of Cylinder Lubricating Oil Consumption	7218-2/A2
Feed Rate – Adjustment	7218-3/A1

Intentionally blank

Cylinder Lubrication

Overview

1.	General	1/14
2.	Description	1/14
3.	Duplex filter and measurement tube	3/14
4.	Cylinder lubricating pump	5/14
5.	ALM-20 module	9/14
6.	Lubricating quill	11/14
7.	Lubrication of exhaust valve spindle	12/14
8.	Cylinder lubricating system – control	13/14

1. General

The cylinder lubrication system operates independently to lubricate the cylinder liners, pistons and exhaust valve spindles. The Wärtsilä Engine Control System (WECS-9520) monitors and controls the adjustable load related feed rate of lubricating oil to each lubrication point.

1.1 Cylinder lubricating oil

During usual operating conditions, a high-additive, alkaline cylinder lubricating oil is necessary.



Remark: Select the alkalinity of the lubricating oil in relation to the sulphur content of the fuel. For more data, see [0750-1](#), paragraph 3.

1.2 Cylinder lubricating oil for running-in



Remark: We recommend that you use the approved, usual cylinder lubricating oil for running-in (see [0410-1](#), paragraph 3).

2. Description

The schematic diagram Fig. 'A' shows the cylinder lubricating system, which has the components that follow:

- Lube oil tank for cylinder lubricating oil (plant side),
- Duplex filter 8.17 (one for each engine),
- Cylinder lubricating pumps 8.06 (one for each cylinder) with control unit ALM-20, 4/2-way solenoid valve and pressure transmitter,
- Lubricating quills 8.09 (six for each cylinder) with non-return valves,
- Pressure reducing valve 8.11 (one for each engine),
- System control from the WECS-9520. For more data, see [4002-1](#), paragraph 3.4.

Cylinder Lubrication

A

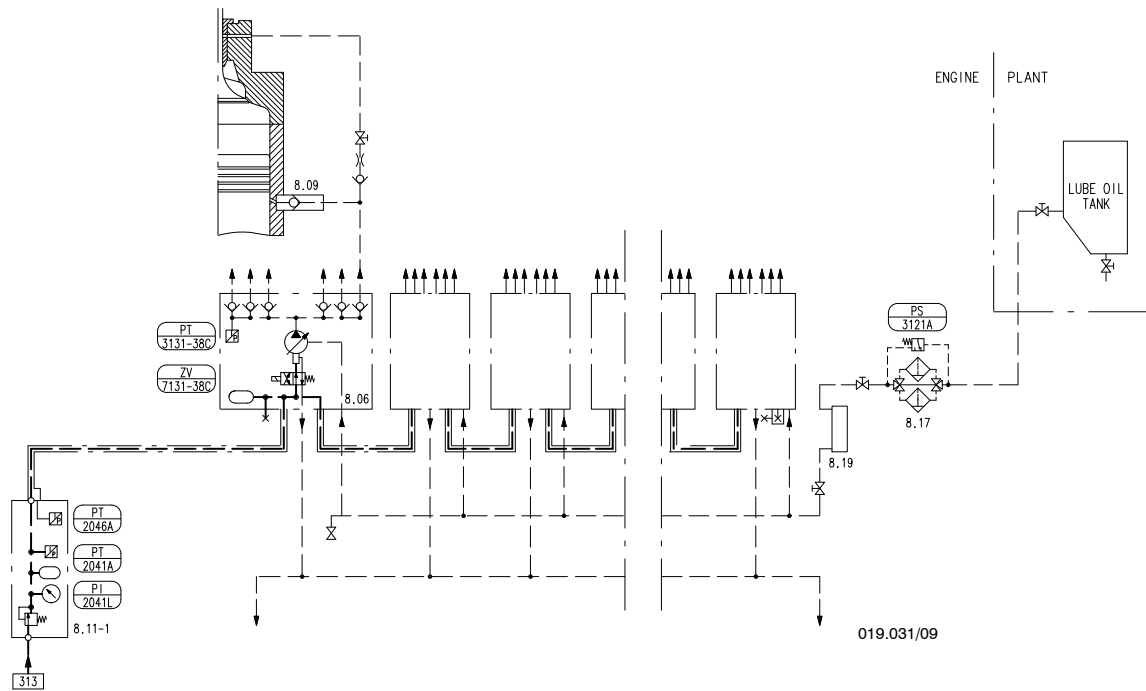

2.1 Lube oil tank

The lube oil tank for the cylinder lubricating oil is installed at a specified height above the engine. This lets static pressure move the oil down. The cylinder lubricating oil flows through the supply pipe to the duplex filter 8.17 and to the cylinder lubricating pumps 8.06.

2.2 Location of the cylinder lubricating pumps

Each cylinder has a cylinder lubricating pump 1 installed on a support on the cylinder block 10 on the fuel side of the engine (see Fig. 'B'). Servo oil, from the servo oil rail at free end, operates the cylinder lubricating pumps (see [8016-1](#), paragraph 4). The related control signal is released from the WECS-9520.

The cylinder lubricating pumps are hydraulically operated. All pumps are connected to the servo oil connecting pipe 7. The pressure reducing valve 2 decreases the servo oil pressure to 60 bar.

For safety, all high-pressure servo oil pipes have double walls. The pressure transmitters 3 and 4 monitor the servo oil pipes. If the pressure decreases, there is a leak. The pressure transmitters transmit a signal with a failure message to the alarm and monitoring system (see [0850-1](#) paragraph 4.7). To do a check of the servo oil pipes, loosen the screw plug 8 (maximum two turns). If servo oil comes out, the servo oil pipes are damaged (see Fig. 'E').

Cylinder Lubrication

B

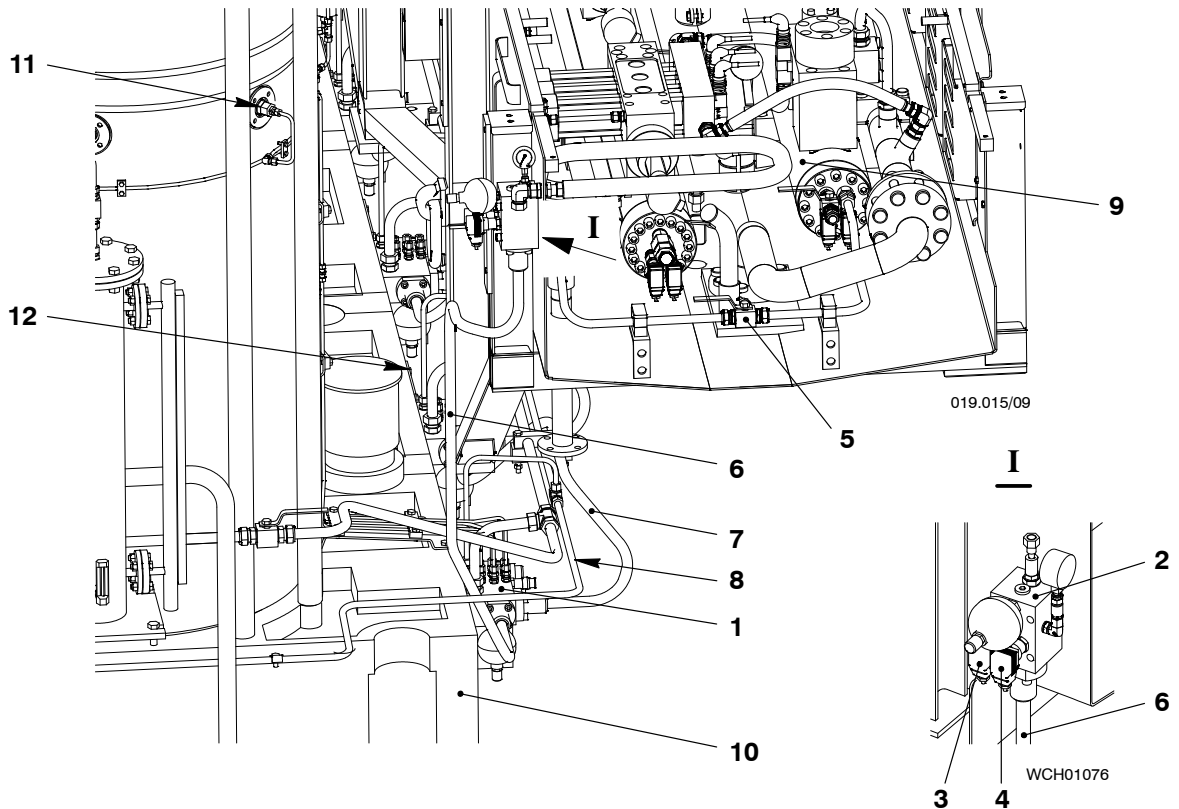
**Key to Illustration: 'B' Location of the cylinder lubricating pumps**

- | | |
|----------------------------------|-----------------------------|
| 1 Cylinder lubricating pump 8.06 | 7 Servo oil connecting pipe |
| 2 Pressure reducing valve 8.11-1 | 8 Servo oil return pipe |
| 3 Pressure transmitter PT2041A | 9 Servo oil rail 4.11 |
| 4 Pressure transmitter PT2046A | 10 Cylinder block |
| 5 Stop valve 4.30-5 | 11 Lubricating quill |
| 6 Servo oil pipe | 12 Support |

3. Duplex filter and measurement tube

The duplex filter 1 and the measurement tube 4 are installed between the lube oil tank and the cylinder lubricating pumps. The differential-pressure sensor 6 monitors the quantity of dirt in the duplex filter. If the filter is clogged, the differential-pressure sensor transmit a signal with a failure message to the alarm and monitoring system.

- ⇒ Make sure that the ball valve 10 is opened during operation.
- ⇒ If necessary, replace the clogged filter element (see paragraph 3.2).

3.1 Vent the duplex filter

It is necessary to vent the duplex filter:

- at the first operation,
- after you replaced a filter element.

Cylinder Lubrication

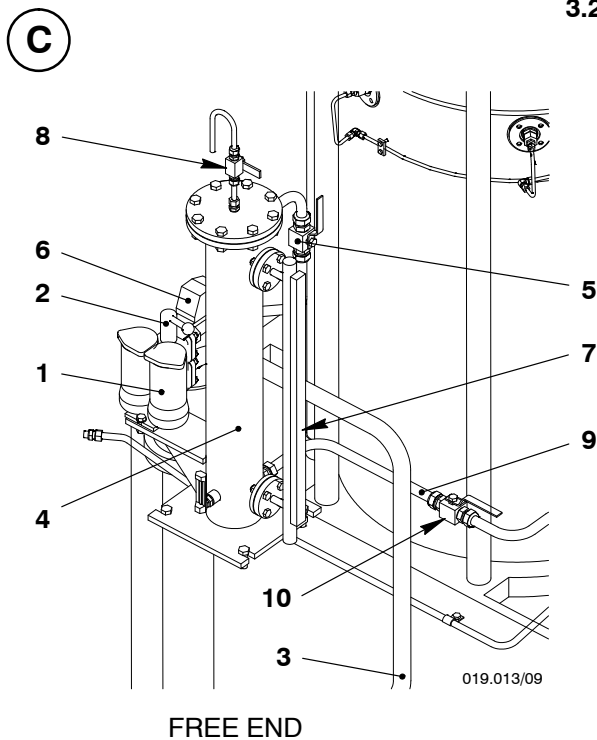
**3.2 Replace the filter element**

It is possible to replace a clogged filter element during operation. Because of the duplex filter, it is not necessary to stop the oil supply. Do the steps that follow:

- ⇒ Set the lever 2 to the other (clean) filter element.
- ⇒ Replace the clogged filter element.

Key to Illustration: 'C'**Filter and measurement tube**

- 1 Duplex filter 8.17
- 2 Lever
- 3 Supply pipe
- 4 Measurement tube 8.19
- 5 Ball valve
- 6 Differential-pressure sensor PS3121A
- 7 Measurement tube with scale
- 8 Venting cock
- 9 Supply pipe
- 10 Ball valve

3.3 Oil consumption measurement

The integrated magnetic level indicator and scale 7 are used to measure the lubricating oil consumption (see Fig. 'C').

The specified, theoretic feed rate is set in the WECS-9520. To change the parameters use the operator interface (see 4002-3, paragraph 1.1).



Remark: Make sure that the lubricating oil level is always above the mark '1'. If not, air can go into the system and cause a malfunction.

To check the parameters and make sure that the lubricating oil system operates correctly, measure the oil consumption at the measurement tube 4.

Do the steps that follow:

- ⇒ Close the ball valve 5.
- ⇒ Open the venting cock 8.
- ⇒ When you can see the oil level on the scale 7, mark the oil level and start the time measurement.
- ⇒ After the specified time (15 to 20 minutes) mark the oil level on the scale again.
- ⇒ Open the ball valve 5.
- ⇒ Keep the venting cock 8 open until oil that flows has no air.
- ⇒ Close the venting cock 8.
- ⇒ Measure the distance between the two marks on the scale 7.
- ⇒ Calculate the oil consumption during the measurement with this conversion factor: 1 cm = 0.14 l.



Remark: The conversion factor is related to the size of the measurement tube. For more data, see the labelling on the measurement tube.

To calculate the specific cylinder lubricating oil consumption (g/kWh), see 7218-2, paragraph 2.1.

Cylinder Lubrication

4. Cylinder lubricating pump

4.1 General

The cylinder lubricating pumps are attached to the cylinder block (see Fig. 'D'). The components of the cylinder lubricating pump can be replaced easily, because of interchangeable modules.

The cylinder lubricating pumps have the parts that follow (see Fig. 'D'):

- Pump body 1
- Baseplate 2
- 4/2-way solenoid valve 3
- Accumulator 4.

An ALM-20 module is installed to each cylinder lubricating pump (see paragraph 5).



Remark: If a cylinder lubricating pump is damaged, the WECS-9520 transmits a signal to decrease the speed of the engine (slowdown). Stop the fuel injection of the related cylinder (see 0510-1, paragraph 1).

Baseplate:

The baseplate 2 contains the main components of the cylinder lubricating pump and the routing of the servo oil pipes.

The shut-off valve 6 (servo oil inlet) is installed in the baseplate.



Remark: Make sure that the shut-off valve 6 is fully open during usual operation. If necessary, close the shut-off valve to replace the 4/2-way solenoid valve 3 (see Fig. 'D' and documentation of the cylinder lubricating pump supplier).

Pump body:

The function of the pump body 1 is to increase the oil pressure and to supply the servo oil.

To vent the cylinder lubricating pump, the venting screws 9 and 10 are installed in the pump body (see paragraph 4.3).

4/2-way solenoid valve:

The 4/2-way solenoid valve 3 is electronically controlled. The valve opens the related oil bore in the pump body to operate the central piston.

Accumulator:

The function of the accumulator 4 is to obtain a good performance of the lubricating module and the lubricating system in general. The accumulator makes sure that the servo oil pressure stays almost constant and unwanted high pressure (pressure fluctuation) is decreased.

To check the gas pre-charge pressure see 7218-1 in the Maintenance Manual.

ALM-20 module (control unit):

The WECS-9520 monitors the correct operation of each cylinder lubricating pump with an ALM-20 module. The ALM-20 modules activate the 4/2-way solenoid valves and sense the servo oil pressure.

LEDs show the status of the cylinder lubricating pump and the control system (see paragraph 5).



Remark: It is possible to replace an ALM-20 module during operation or when the engine has stopped (see 4002-4, paragraph 4 and 9362-1, paragraph 2).

Cylinder Lubrication

D

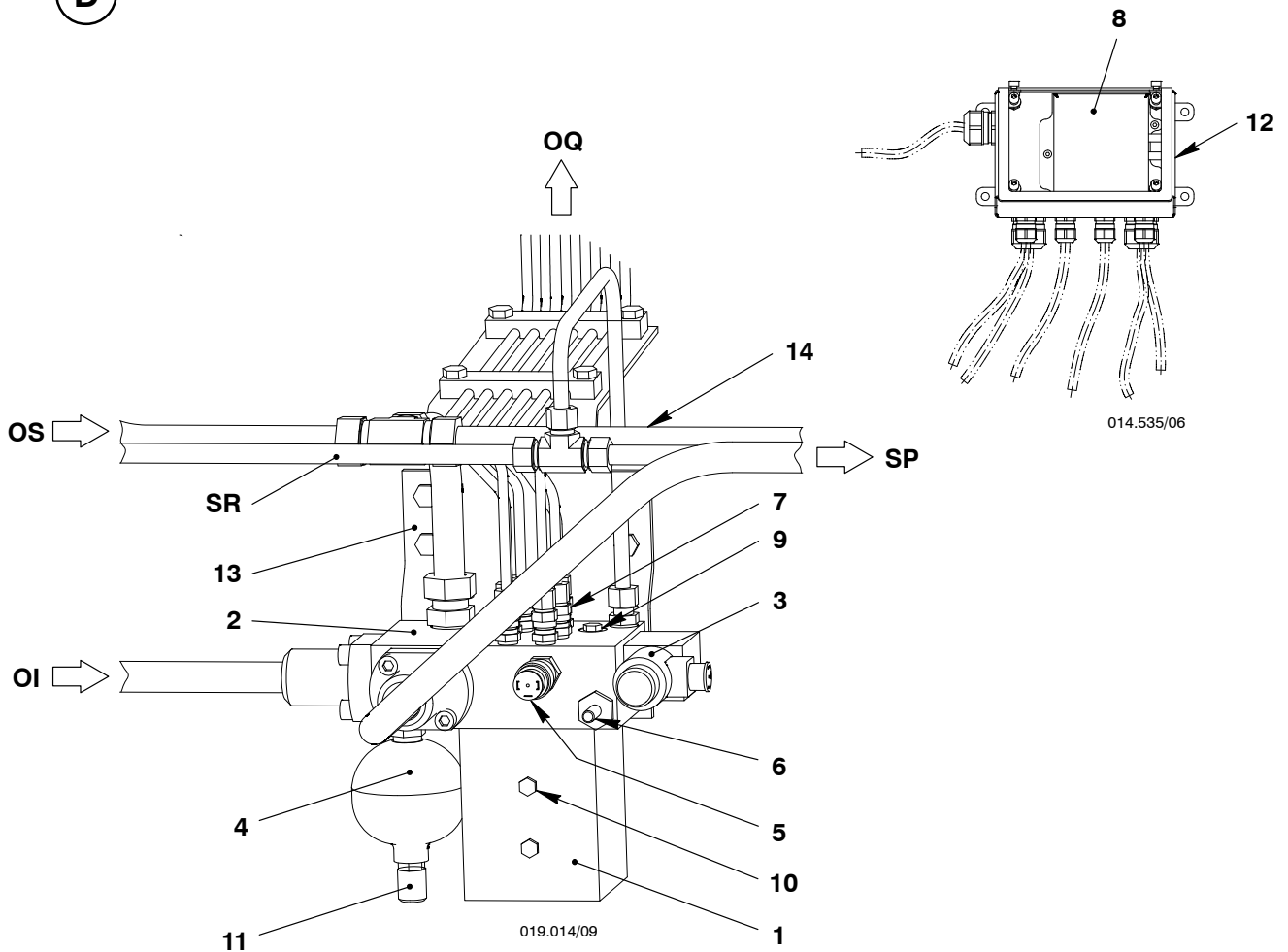
**Key to Illustration: 'D' Cylinder lubricating pump**

- | | |
|------------------------------------------------|---------------------------------------|
| 1 Pump body | 11 Test port and fill connection |
| 2 Baseplate | 12 Control box E41.01-08 |
| 3 4/2-way solenoid valve ZV7131-38C | 13 Support |
| 4 Accumulator | 14 Supply pipe |
| 5 Pressure transmitter PT3131-38C | |
| 6 Shut-off valve (servo oil) | OQ Oil to lubricating quill |
| 7 Lubricating oil outlet with non-return valve | OS Oil supply |
| 8 ALM-20 module | OI Servo oil inlet |
| 9 Venting screw (servo oil) | SR Servo oil return |
| 10 Venting screw (lubricating oil) | SP Servo oil to next lubricating pump |

4.2 Function

The WECS-9520 operates the 4/2-way solenoid valve 3 and servo oil flows through the valve to the bottom of the central piston. The pressure of the servo oil pushes the central piston to the top end position. The servo oil from the top of the central piston flows through the 4/2-way solenoid valve into the servo oil return pipe. The supply piston opens the lubricating oil inlet and the metering ducts are filled with lubricating oil.

Cylinder Lubrication

When the WECS-9520 sends a signal to the ALM-20 module, the 4/2-way solenoid valve operates. Servo oil flows to the top of the central piston. The servo oil from the bottom flows through the 4/2-way solenoid valve into the servo oil return pipe. The central piston moves down to the bottom end position. The lubricating oil flows at high pressure through the non-return valve into the lubricating oil outlet ports. The lubricating quills inject the lubricating oil into the cylinder liner.

The maximum stroke of the central piston is adjustable with a set-screw. Thus, the movement and the feed rate is equal for all supply pistons.

4.3 Vent the cylinder lubricating pump



Remark: Make sure that the cylinder lubricating system is prepared for operation (see 0140-1).

To vent the cylinder lubricating pump, open the venting screw 9 (servo oil) in baseplate 2 and the venting screw 10 (lubricating oil) in pump body 1 (see Fig. 'E').

It is necessary to vent the cylinder lubricating pump:

- at first operation
- after a long shutdown period
- after maintenance works
- if there is a problem during operation (e.g. operating pressure, feed rate).

Lubricating oil:

- ⇒ Put an oil tray below the cylinder lubricating pump.
- ⇒ Carefully loosen the venting screw 10 (maximum three turns).
- ⇒ Keep the venting screw 10 open until oil that flows has no air.
- ⇒ Close the venting screw 10.
- ⇒ Remove the oil tray.

Servo oil:



Attention! The servo oil system operates at high pressure. When you loosen the venting screws, oil can come out as a spray. Always wear safety goggles and gloves!

- ⇒ Put an oil tray below the cylinder lubricating pump.
- ⇒ On the operator interface, select the related cylinder number in the menu MANUAL LUBRICATION ON CYL. As an alternative, set the switch to MANUAL EMERGENCY on the related 4/2-way solenoid valve 3 (see Fig. 'E').
- ⇒ Loosen the venting screw 9 (maximum three turns).
- ⇒ Keep the venting screw 9 open until oil that flows has no air.
- ⇒ Close the venting screw 9.
- ⇒ Remove the oil tray.

Cylinder Lubrication

E

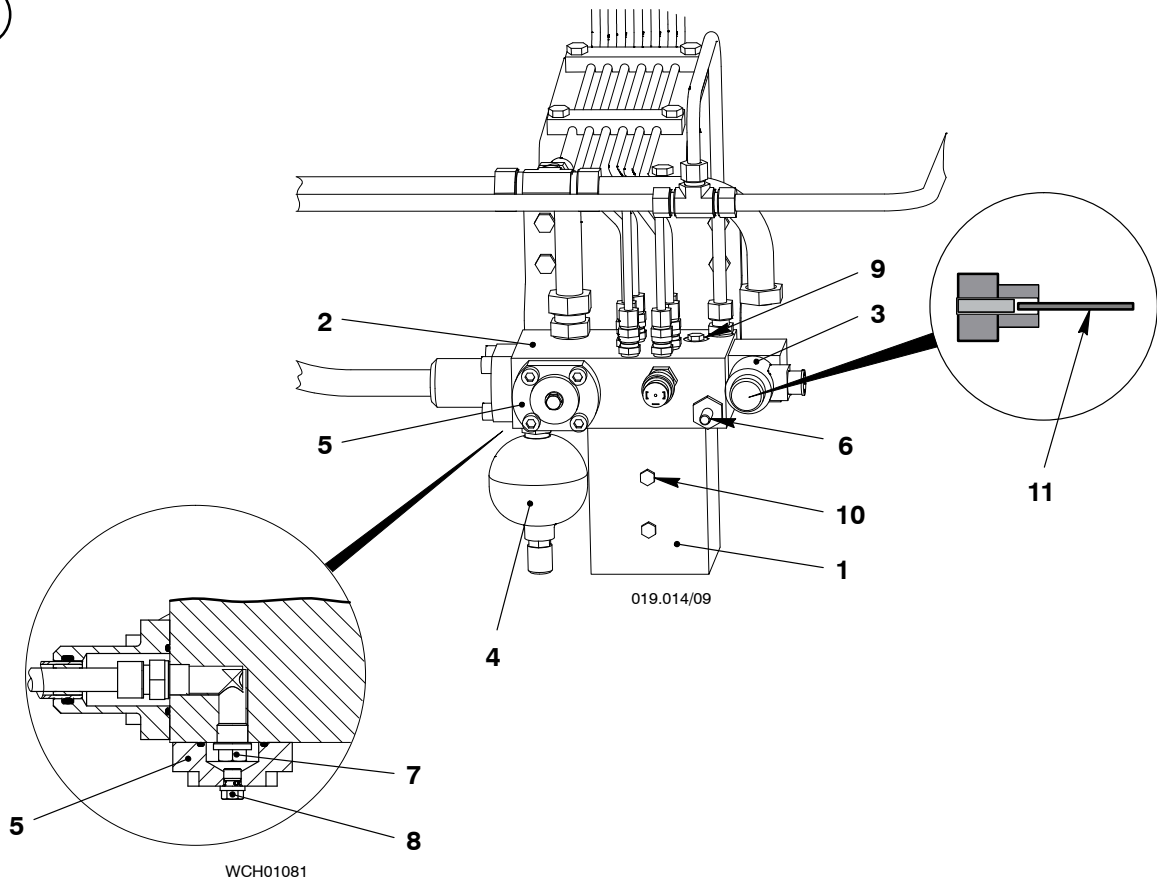
**Key to Illustration: 'E' Last cylinder lubricating pump**

- | | |
|-------------------------------------|------------------------------------|
| 1 Pump body | 7 Screw plug |
| 2 Baseplate | 8 Screw plug |
| 3 4/2-way solenoid valve ZV7131-38C | 9 Venting screw (servo oil) |
| 4 Accumulator | 10 Venting screw (lubricating oil) |
| 5 Blind flange | 11 Assembly pin (max. Ø 3.5 mm) |
| 6 Shut-off valve (servo oil) | |

4.4 Vent the lubricating oil system

Remark: Vent the pipes to the lubricating quills after you have vented the filter, the measurement tube and cylinder lubricating pumps.

Do the steps that follow:

- ⇒ Loosen all cap nuts of the pipes approximately two turns (see 2138-1).
- ⇒ On the operator interface, select the related cylinder number in the menu MANUAL LUBRICATION ON CYL. As an alternative, set the switch to MANUAL EMERGENCY on the related 4/2-way solenoid valve (see Fig. 'E').
- ⇒ Keep the cap nuts open until oil that flows has no air.
- ⇒ Close the cap nuts.



Remark: After all the lubricating oil pipes of a cylinder are vented, you can visually examine the cylinder oil supply. Make sure that the piston is in position TDC. Look through the scavenge air ports in the cylinder liner, while the lubricating system operates.

Cylinder Lubrication



Remark: To manually release a single lube pulse you can push in the assembly pin 11 (see Fig. 'E'). The manual lubrication is different to the pre-lubrication. Pre-lubrication is part of the PLS control system and operates automatically.

4.5 Cylinder lubricating pump components – maintenance

If it is necessary to do an overhaul or replace cylinder lubricating pump components, see the maintenance procedures in the cylinder lubricating pump supplier documentation.

For faults, causes and repair procedures, see 0820-1 paragraph 3 and the cylinder lubricating pump supplier documentation.

5. ALM-20 module

The function of the ALM-20 module is to operate the 4/2-way solenoid valve and to measure the metering pressure. The ALM-20 module monitors the lubricating quills for blockages, air locks, a decrease of lubricating oil and operation problems.

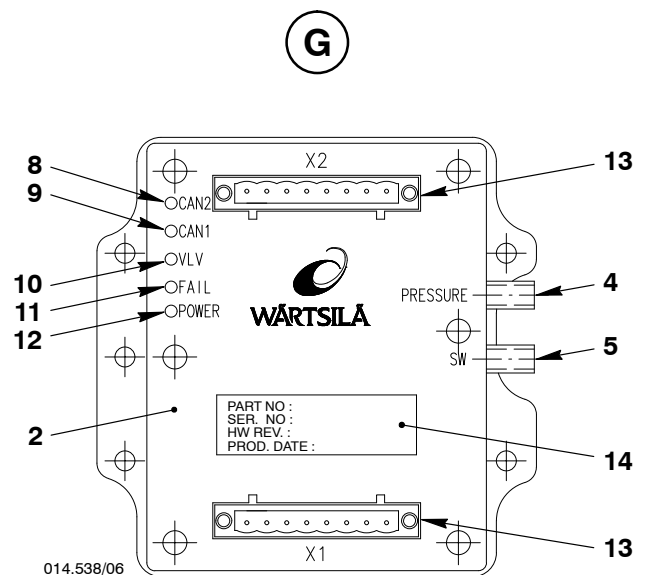
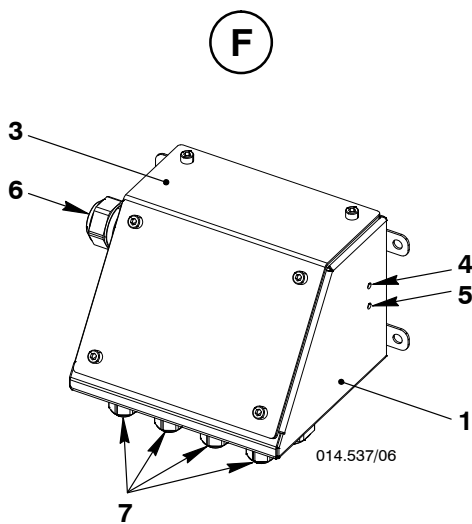

Key to Illustrations: 'F' Control box

'G' ALM-20 module

- | | |
|------------------------------------------|-------------------|
| 1 Control box E41.01-08 | 8 LED (CAN2) |
| 2 ALM-20 module | 9 LED (CAN1) |
| 3 Cover | 10 LED (VLV) |
| 4 LED (pressure) | 11 LED (FAIL) |
| 5 LED (SW) | 12 LED (POWER) |
| 6 Cable connection (to lubricating pump) | 13 Plug (X1 / X2) |
| 7 Cable connections (to control) | 14 Name plate |

Cylinder Lubrication

5.1 LED indications

LEDs 4 and 5 show the status of the cylinder lubricating pump and the control system (see Fig. 'F' and Fig. 'G'). The LEDs are visible on the outer surface of the ALM-20 module.

LED	Indication	Status
LED 4 (pressure)	flashes yellow	Indicates a satisfactory lube pulse
	shows red	Indicates an electrical short-circuit of the pressure transmitter (PT3131-38C)
LED 5 (SW)	flashes green	Module ready for software download
	shows green	Ready for operation



Remark: A lube pulse is not released at each piston stroke. At part load, the lube pulses start only after some piston strokes.

When the cover 3 is removed from the ALM-20 module, you can see LEDs that give more data (see Fig. 'H').

LED	Indication	Status
LEDs 8 / 9 (CAN2 / CAN1)	shows yellow	Active CAN Bus
	shows red	Defective CAN Bus (failure)
LED 10 (VLV)	flashes yellow	Indicates a released lube pulse
	shows red	and LED 11 (FAIL) shows red: Indicates an electrical short-circuit of the 4/2-way solenoid valve
	shows red	and LED 11 (FAIL) flashes red (one time): Indicates a defective cable at the 4/2-way solenoid valve
LED 11 (FAIL)	none	Electrical circuit of the injection system ready for operation
	shows red	and LED 10 (VLV) none: Indicates an electrical short-circuit of the pressure transmitter (PT3131-38C)
	flashes red (two times)	Indicates a defective cable at the pressure transmitter (PT3131-38C)
	flashes red (three times)	Shows an identification failure of the ALM-20 module
LED 12 (POWER)	shows green	Power supply is on
	none	Power supply is off

Cylinder Lubrication

5.2 Resistor in plug X1

Each ALM-20 module has a built-in resistor in the plug X1 (at terminals 16 and 17). The value of each resistor is related to the cylinder number.



Remark: Before you install a new resistor, make sure that the replacement has the correct resistance. See the table that follows:

Cylinder No.	Control box No.	Resistance Ohm [Ω]
1	E41.01	330
2	E41.02	390
3	E41.03	470
4	E41.04	560
5	E41.05	680
6	E41.06	820
7	E41.07	1.0K
8	E41.08	1.2K

6. Lubricating quill

Lubricating oil is injected on to the cylinder liner wall through the lubricating quills installed on the circumference of the cylinder liner.

For more data about the lubricating quills, see [2138-1](#).

Cylinder Lubrication

7. Lubrication of exhaust valve spindle

The cylinder lubricating pump 1 supplies lubricating oil through the lubricating oil pipe to the exhaust valve 4 (see Fig. 'I'). At each lube pulse, some lubricating oil flows through the non-return valve 5, orifice 6 and stop valve 7 into the exhaust valve (see Fig. 'H').

Service experience show that the additional lubrication of the exhaust valve spindle is only necessary during the initial hours of engine operation or after an exhaust valve overhaul (see also 2751-1). During usual operating condition the valve 7 is closed.



Remark: We recommend that you close the stop valve:

- after the sea trial (approximately 100 operating hours).
- approximately 24 operation hours after an overhaul of the exhaust valve.

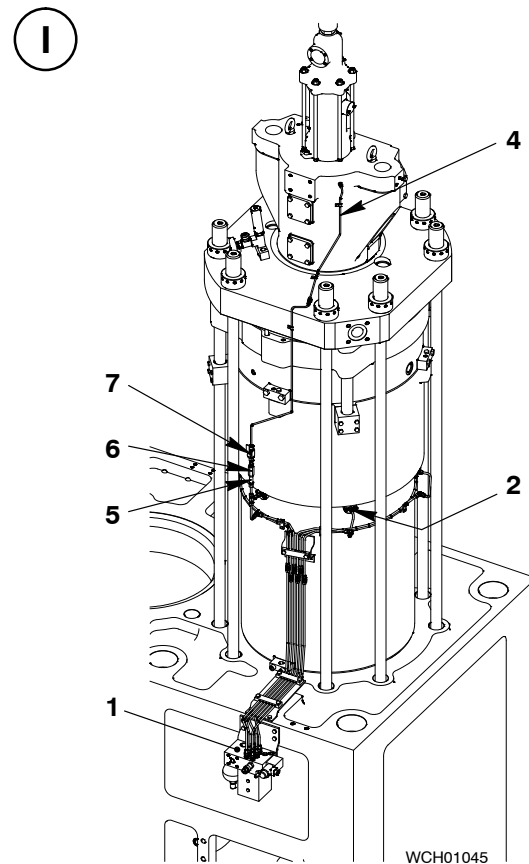
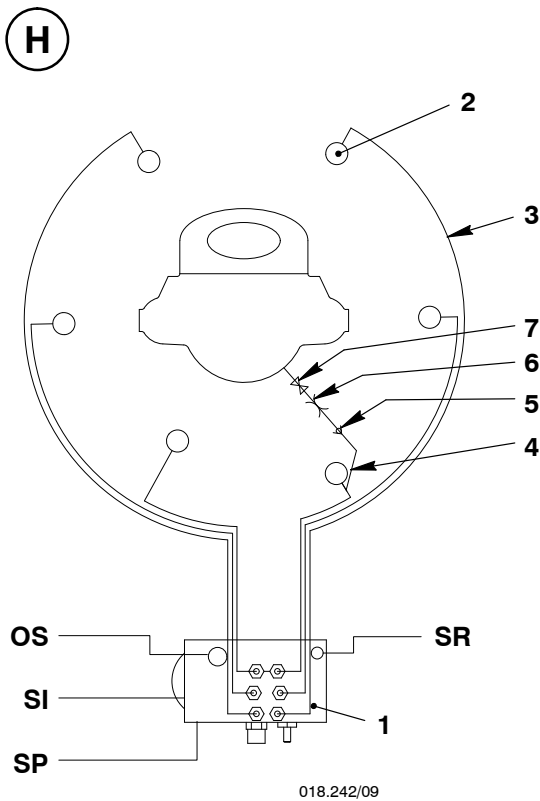

Key to Illustrations: 'H' Schematic diagram
'I' Configuration cylinder No. 1

1	Cylinder lubricating pump 8.06	OS	Oil supply
2	Lubricating quill 8.09	SI	Servo oil inlet
3	Lubricating oil pipe to lubricating quill	SR	Servo oil return
4	Lubricating oil pipe to exhaust valve	SP	Servo oil to next pump
5	Non-return valve		
6	Orifice		
7	Stop valve		

Cylinder Lubrication

8. Cylinder lubricating system – control

8.1 Control system

J

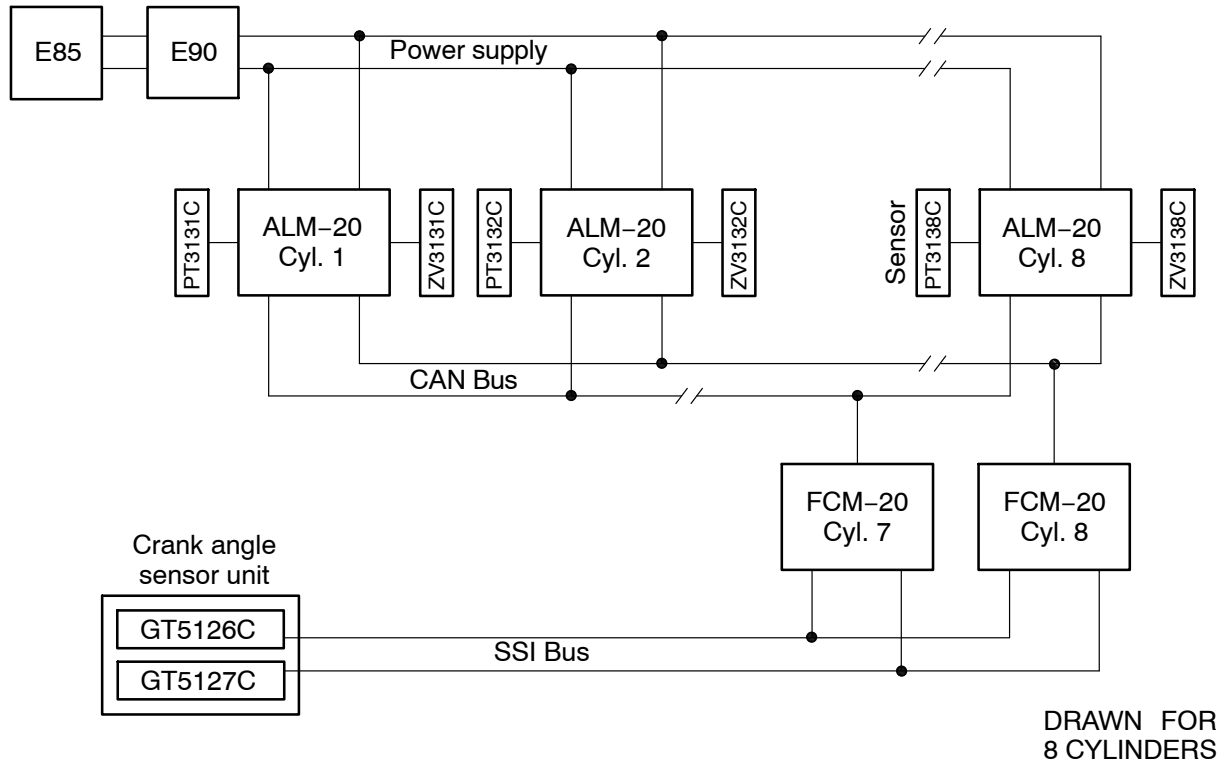

The WECS-9520 controls the cylinder lubricating system.

The control system includes a row of ALM-20 modules, one module for each cylinder. The CAN Bus transmits the signals. To prevent faults one more CAN Bus is installed and gives redundancy. Each ALM-20 module has a pressure transmitter to monitor the metering pressure. The necessary power for the ALM-20 modules is supplied through the power supply box E85 and the control box E90.

The FCM-20 modules get the necessary information from the last and next to last cylinder. The SSI Bus transmits the signals from the crank angle sensors. To prevent faults one more SSI Bus is installed and gives redundancy (see 4002-1).

The 4/2-way solenoid valves operate the cylinder lubricating pump (ZV3132C).

Cylinder Lubrication

8.2 Radial oil distribution

The nozzle tip in the lubricating quill has holes in specified positions (see Fig. 'K'). The lubricating oil flows out of these holes at high pressure. The lubricating grooves give equal lubrication on to the cylinder liner wall (see also 2138-1).

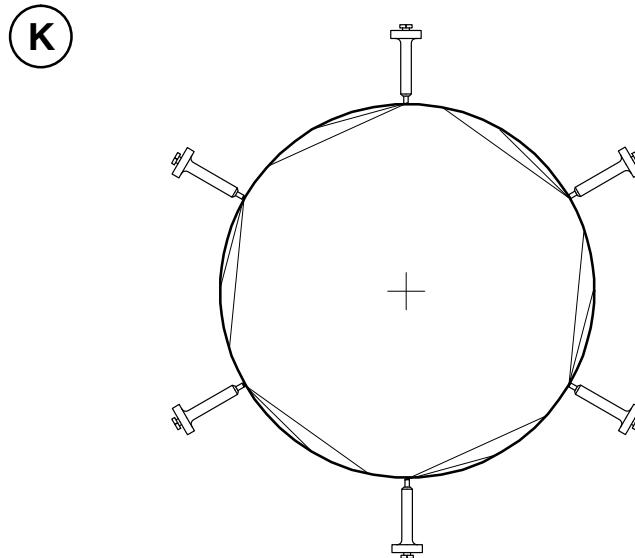

8.3 Vertical oil distribution

The WECS-9520 controls the injection timing of the vertical oil supply (see 4002-1, paragraph 4.4). The parameters of the oil feeds are set during the first operation of the engine.

The specified quantities are (see Fig. 'L'):

- 70% above
- 25% into
- 5% below the piston head.

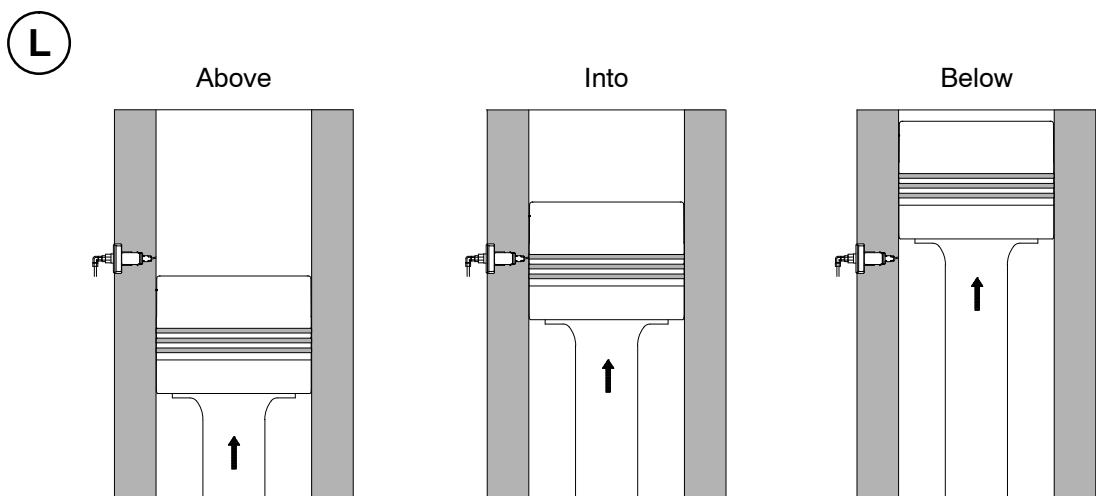

018.650/09

Cylinder Lubrication

8.4 Adjustment – Lubricating oil feed rate

It is possible to adjust the lubricating oil feed rate in the range 0.5 g/kWh to 3.0 g/kWh, in steps of 0.1 g/kWh. Use the user parameters in the columns 'Feed Rate' and 'Adjustment' for one cylinder, or for all cylinders (see [4002-3](#), paragraph 1.1).

For data about the guide feed rates for running-in of new cylinder liners and piston rings, see [0410-1](#), paragraph 4 and [0410-1](#), paragraph 5).

Intentionally blank

Instructions Concerning Measurement of Cylinder Lubricating Oil Consumption

1. Calculate the cylinder lubricating oil consumption

You can measure the cylinder lubricating oil consumption at all engine power outputs.

The engine has a load-related cylinder lubricating system. To get a correct result, make sure that the engine speed and power are kept as constant as possible.

The cylinder lubricating system has a measurement tube, which has a scale that gives accurate measurement of the lubricating oil consumption in a short time.

For data about the measurement procedure see [7218-1](#) paragraph 3.3.

Calculate the specified cylinder lubricating oil consumption, for a) + b):

To calculate the specific cylinder lubricating oil consumption, you must know the power output during the test. Get the engine output:

- a) From the curve fuel injection quantity (%) x engine speed (FQ x rpm)
Make sure that the curve refers to the used fuel (see the acceptance protocol).
- b) From the field Est. Power [%] shown in the operator interface.

$$\text{Specified cylinder lubricating oil consumption} = \frac{1000 \times G}{P} \text{ g/kWh (g/BHP)}h$$

G = Cylinder lubricating oil consumption [kg/h]

P = Engine power output in kW (BHP) given from the curve FQ x rpm
or nominal power x estimated power [%]

2. Calculate the theoretical cylinder lubricating oil consumption

The specified theoretical feed rate is set in the WECS-9520. To change the parameters, use the Operator Interface (see [4002-3](#), paragraph 1.1).

Use the formula below to calculate the cylinder lubricating oil consumption (kg/h):

$$G = \frac{3600 \times V \times \rho \times Z}{t}$$

V = Supply volume of the lubricating oil pump for each injection pulse [ml]

ρ = Oil density [kg/l]

Z = Number of injection pulses

T = Measurement time [s]

Instructions Concerning Measurement of Cylinder Lubricating Oil Consumption

2.1. Calculate the cylinder lubricating oil consumption of a consumption measurement

You use a a consumption measurement (parallel measurement) to do a check of the parameter settings and function of the cylinder lubricating system.

For data about the measurement procedure see 7218-1 paragraph 3.3.

Use the formula below to calculate the cylinder lubricating oil consumption (feed rate):

$$R = \frac{3600 \times (h \times k) \times \rho}{f \times t \times P}$$

R = Cylinder lubricating oil consumption [g/kWh]

h = Measurement height [cm]

k = Conversion factor [l/cm]

ρ = Oil density [g/l]

t = Measurement time [s]

P = Engine power output [kW]

f = Correction factor (see table that follows)

Engine power output %	Correction factor f
100	1.00
75	1.02
50	1.06
20	1.25
10	1.56

Example 8 RT-flex58T-D:

$$R = \frac{3600 \times (21.0 \times 0.14) \times 920}{1.02 \times 900 \times 13560} = 0.8 \text{ g/kWh}$$

- Measurement time 15 min = 900 s
- Measuring height 21.0 cm
- Conversion factor 0.14 l/cm
- Oil density 920 g/l
- Output at 75% 13560 kW
- Correction factor 1.02

Instructions Concerning Measurement of Cylinder Lubricating Oil Consumption

3. Recommended cylinder lubricating oil feed rate

We recommend to decrease the cylinder lubricating oil feed rate gradually, after running-in the engine (see [0410-1](#)).

The set value refers to the nominal output at nominal speed. Because of the load-related lubricating system, this value stays almost constant.

Adjust the feed rate to service experiences (e.g. running surfaces of pistons, piston rings and cylinder liners).

When data is given to us about the consumption of cylinder lubricating oil, it must always be related to liter or kg / hour or each period of 24 hours, and shows at the same time (as far as known):

The data must include:

- Engine type and number of cylinders
- Engine speed
- Fuel injection quantity
- Set lubricating oil volume
- Number of pulses during measurement
- Engine power output during measurement
- Supply volume of the lubricating pump
- Lubricating oil specifications
- Fuel oil specifications
- Fuel oil consumption in metric tons each period of 24 hours.

Intentionally blank

Feed Rate – Adjustment

Overview

1.	General	1/8
2.	Base Feed Lubrication	3/8
3.	Sulphur Dependent Lubrication	3/8
4.	Safeguard Sulfur Dependent Lubrication	5/8
5.	Blending on Board	7/8

1. General

To set the correct cylinder lubricating oil feed rate, it is very important to monitor the piston running performance of the engine. The procedures that follow are necessary:

- Use an on-board monitoring programme to monitor the piston underside (PU) drain oil. Make an analysis of the Fe content, Cr content and the residual base number (BN) from the PU drain oil. For more data, see Fig. 2 and 0750-1 Lubricating Oils, paragraph 3.2.
- At regular intervals, visually examine the PU.
- Make an analysis of the fuel quality. If possible, send a sample of the fuel to a laboratory to make an analysis of the effective sulfur content. Do the analysis before you use the fuel oil for the first time.



Note: Engines with the same design can have different piston running performances (because of different operation modes, the properties of the used cylinder lubricating oil or the engine tuning). The most important problem is that cold corrosion can occur and causes faster or more dangerous wear on piston running components.

There are different engine operation modes and operation responses. Each engine operation mode needs an applicable cylinder lubrication set-up. To find the correct set-up, see the data given in paragraph 2, paragraph 3 and paragraph 4.

The setting of the sulfur dependency category is related to the residual BN in the PU drain oil of the engine (see 0750-1 Lubricating Oils, paragraph 3.2).

Table 1 shows data about the different feed rates used in this manual.

Table 1: Feed Rate Glossary

Guide Feed Rate	Recommended base feed rate, e.g. 0.8 g/kWh for pulse lubricating systems.
Base Feed Rate	Adjusted feed rate in the lubricating system. Load dependent without sulfur dependency.
Sulfur Dependant Feed Rate	Adjusted feed rate in the lubricating system. Load dependent with sulfur dependency.
Effective Feed Rate	Actual feed rate. Load dependent and also sulfur dependent, if applicable.

Set the applicable adjustment of the cylinder lubricating feed rate in relation to the fuel sulfur content, cylinder lubrication BN and engine load. See the flow diagram given in Fig. 1 to find the applicable cylinder lubricating feed rate.

Feed Rate – Adjustment



Note: Winterthur Gas & Diesel Ltd. strongly recommends that you use an on-board monitoring programme to make a subsequent analysis of:

- The Fe content
- The Cr content
- The residual base number (BN) from the PU drain oil.

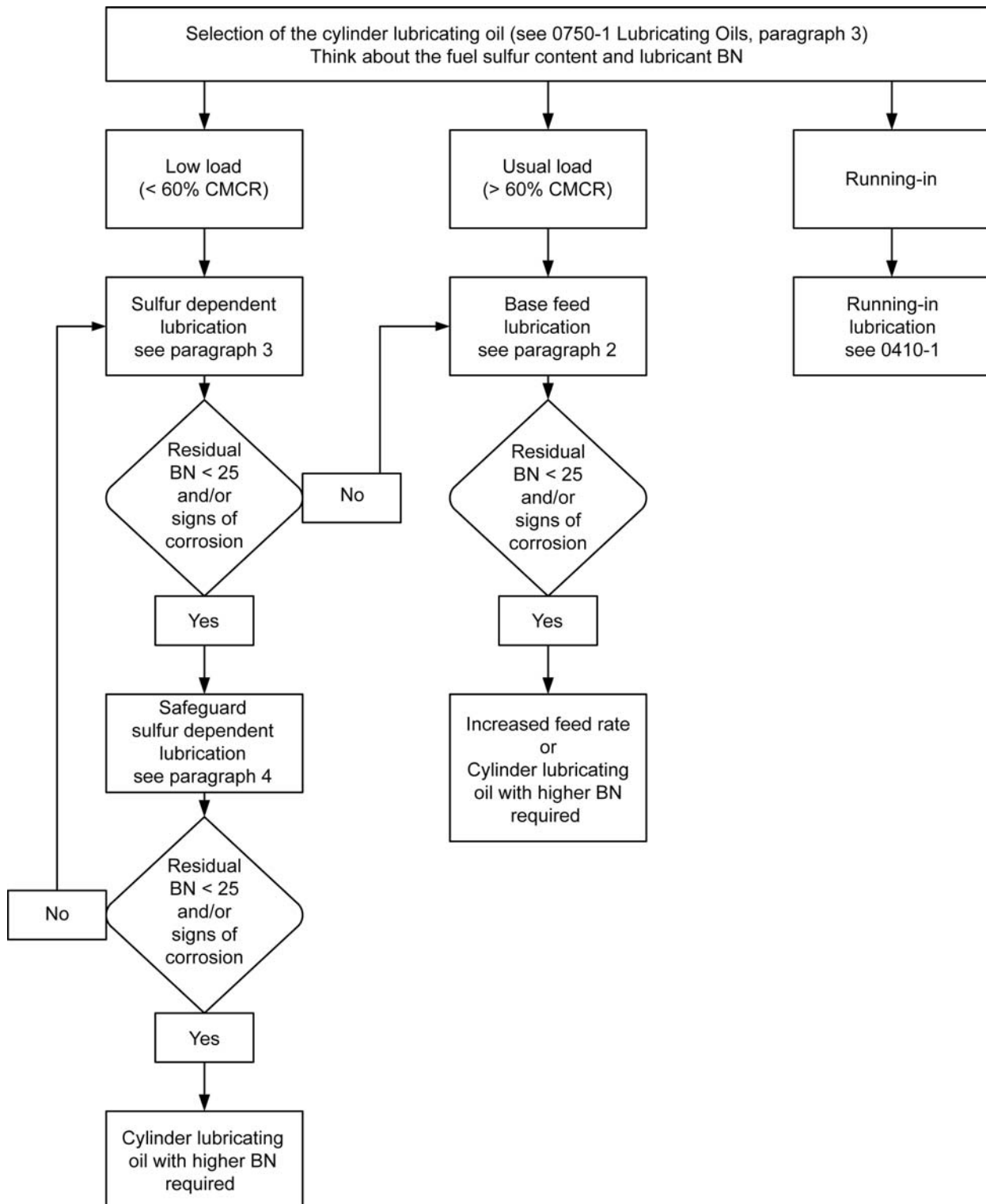

Fig. 1: Selection of the Cylinder Lubricating Oil Feed Rate

Feed Rate – Adjustment



Fig. 2 PU Drain Oil Residual BN

2. Base Feed Lubrication (Engine Load is More than 60% CMCR)

The recommended base feed rate for pulse lubricating systems is 0.8 g/kWh.



Note: When the engine load is more than 60% CMCR, Wärtsilä Services Switzerland Ltd. recommends that you set the base feed rate as a function of the used cylinder lubricating system.

3. Sulfur Dependent Lubrication (Engine Load is Less than 60% CMCR)

During low load operation, the conversion of the sulfur in the HFO into sulfuric acid increases. The alkaline additives in the cylinder lubricating oil make the acidic components neutral. For more data, see see [0750-1 Lubricating Oils](#), paragraph [3.3](#).

Wärtsilä Services Switzerland Ltd. recommends that you use a sulfur dependent feed rate if the engine operates at less than 60% CMCR (see [Table 2](#)).

To increase the protective chemical properties of the cylinder lubricating oil at low load operation, Wärtsilä Services Switzerland Ltd. recommends that you adjust the cylinder lubricating oil feed rate. Refer to the data that follows to set the cylinder lubricating oil feed rate:

- The base feed rate [g/kWh]
- The sulfur content [% m/m] of the used residual HFO
- BN [mg KOH/g] of the used cylinder lubricating oil
- Installed cylinder lubricating system
- PU drain oil residual BN.



Equipment Hazard: The results of the bunker analysis and the values given in the Bunker Delivery Note (BDN) can be different. Always use the higher sulfur content value to set the correct feed rate to make sure that the engine operates safely.



Note: Use the cylinder lubricating oil feed rates given in [Table 2](#) as a function of the used cylinder lubricating system, cylinder lubricating oil and fuel.

See the data given in [Table 2](#) to set the sulfur dependent cylinder lubricating oil feed rate (LOFR) for pulse lubricating systems (PLS) and systems with a guide feed rate of 0.8 g/kWh at CMCR.

Feed Rate – Adjustment

**Table 2: Setting Table – PLS Sulfur Dependent Feed Rate
at Low Load (less than 60% CMCR) (Calculated Values, Last Update March 2014)**

Sulfur Content [%]	Lubricating Oil Feed Rate [g/kWh]						
	BN 40	BN 50	BN 60	BN 70	BN 80	BN 90	BN 100
0.0							
0.1	0.80 ⁽³⁾						
0.2	0.80 ⁽³⁾						
0.3	0.80 ⁽³⁾						
0.4	0.80 ⁽³⁾						
0.5	0.80	0.80 ⁽³⁾	0.80 ⁽³⁾				
0.6	0.80	0.80 ⁽³⁾	0.80 ⁽³⁾				
0.7	0.80	0.80 ⁽³⁾	0.80 ⁽³⁾				
0.8	0.80	0.80 ⁽³⁾	0.80 ⁽³⁾				
0.9	0.80	0.80 ⁽³⁾	0.80 ⁽³⁾				
1.0	0.80	0.80	0.80	0.80 ⁽³⁾	0.80 ⁽³⁾		
1.1	0.80	0.80	0.80	0.80 ⁽³⁾	0.80 ⁽³⁾		
1.2	0.80	0.80	0.80	0.80 ⁽³⁾	0.80 ⁽³⁾		
1.3	0.80	0.80	0.80	0.80 ⁽³⁾	0.80 ⁽³⁾		
1.4	0.80	0.80	0.80	0.80 ⁽³⁾	0.80 ⁽³⁾		
1.5	0.80	0.80	0.80	0.80	0.80		
1.6	0.80 ⁽³⁾	0.80	0.80	0.80	0.80		
1.7	0.80 ⁽³⁾	0.80	0.80	0.80	0.80		
1.8	0.85 ^{(2), (3)}	0.80	0.80	0.80	0.80		
1.9	0.90 ^{(2), (3)}	0.80	0.80	0.80	0.80		
2.0	0.95 ^{(2), (3)}	0.80	0.80	0.80	0.80	0.80 ⁽³⁾	0.80 ⁽³⁾
2.1		0.80	0.80	0.80	0.80	0.80 ⁽³⁾	0.80 ⁽³⁾
2.2		0.80	0.80	0.80	0.80	0.80 ⁽³⁾	0.80 ⁽³⁾
2.3		0.85 ⁽²⁾	0.80	0.80	0.80	0.80 ⁽³⁾	0.80 ⁽³⁾
2.4		0.90 ⁽²⁾	0.80	0.80	0.80	0.80 ⁽³⁾	0.80 ⁽³⁾
2.5		0.95 ⁽²⁾	0.80	0.80	0.80	0.80	0.80
2.6			0.80 ^{(2), (4)}	0.80	0.80	0.80	0.80
2.7			0.85 ^{(2), (4)}	0.80	0.80	0.80	0.80
2.8			0.85 ^{(2), (4)}	0.80	0.80	0.80	0.80
2.9			0.90 ^{(2), (4)}	0.80	0.80	0.80	0.80
3.0			0.95 ^{(2), (4)}	0.80	0.80	0.80	0.80
3.1			0.95 ^{(2), (4)}	0.85 ⁽²⁾	0.80	0.80	0.80
3.2			1.00 ^{(2), (4)}	0.85 ⁽²⁾	0.80	0.80	0.80
3.3			1.00 ^{(2), (4)}	0.90 ⁽²⁾	0.80	0.80	0.80
3.4			1.05 ^{(2), (4)}	0.90 ⁽²⁾	0.80	0.80	0.80
3.5 ⁽¹⁾			1.10 ^{(2), (4)}	0.95 ⁽²⁾	0.80	0.80	0.80
3.6				0.95 ⁽²⁾	0.85 ⁽²⁾	0.80	0.80
3.7				1.00 ⁽²⁾	0.85 ⁽²⁾	0.80	0.80
3.8				1.05 ⁽²⁾	0.85 ⁽²⁾	0.80	0.80
3.9				1.05 ⁽²⁾	0.90 ⁽²⁾	0.80	0.80
4.0				1.10 ⁽²⁾	0.90 ⁽²⁾	0.80	0.80
4.1				1.10 ⁽²⁾	0.95 ⁽²⁾	0.80	0.80
4.2				1.15 ⁽²⁾	0.95 ⁽²⁾	0.85 ⁽²⁾	0.80
4.3				1.15 ⁽²⁾	1.00 ⁽²⁾	0.85 ⁽²⁾	0.80
4.4				1.20 ⁽²⁾	1.00 ⁽²⁾	0.90 ⁽²⁾	0.80
4.5				1.20 ⁽²⁾	1.05 ⁽²⁾	0.90 ⁽²⁾	0.85 ⁽²⁾

(1) Marpol Annex VI: Limit 3.50% sulfur content

(2) Adjusted lubricating oil feed rate from 0.8 g/kWh to the new value.

(3) Lubricating oil feed rate setting for temporary operation (less than 48 hours).

(4) If no on-board monitoring system for PU drain oil is used, there is a 2.5% limit of sulfur content (see also 0750-1 Lubricating Oils, paragraph 3.2).

Feed Rate – Adjustment

4. Safeguard Sulfur Dependent Lubrication (Engine Load is Less than 60% CMCR)

If the data given in paragraph 3 is not sufficient to prevent corrosion, Wärtsilä Services Switzerland Ltd. recommends that you apply the safeguard sulfur dependency.

You know that there is cold corrosion if:

- You see visual signs of cold corrosion on the piston rings and the cylinder liner
- The analysis of the PU drain oil shows a base number that is less than the recommended limits or more than the usual Fe and Cr content values. For more data, see 0750-1 Lubricating Oils, paragraph 3.2.

If you find signs of cold corrosion, Wärtsilä Services Switzerland Ltd. recommends that you set the lubricating feed rates to the safeguard sulfur dependent values (see Table 3). Use also all other applicable procedures to decrease cold corrosion.

For more data about cold corrosion, see 0750-1 Lubricating Oils, paragraph 3.2 and paragraph 3.3.

See the data given in Table 3 to set the safeguard sulfur dependent LOFR for pulse lubricating systems (PLS) and systems with a guide feed rate of 0.8 g/kWh at CMCR.

Feed Rate – Adjustment

Table 3: Setting Table – PLS Safeguard Sulfur Dependent Feed Rate at Low Load (less than 60% CMCR) (Calculated Values, Last Update March 2014)

Sulfur Content [%]	Lubricating Oil Feed Rate [g/kWh]					
	BN 50	BN 60	BN70	BN 80	BN 90	BN 100
0.0						
0.1						
0.2						
0.3						
0.4						
0.5	0.80 ⁽³⁾	0.80 ⁽³⁾				
0.6	0.80 ⁽³⁾	0.80 ⁽³⁾				
0.7	0.80 ⁽³⁾	0.80 ⁽³⁾				
0.8	0.80 ⁽³⁾	0.80 ⁽³⁾				
0.9	0.80 ⁽³⁾	0.80 ⁽³⁾				
1.0	0.80	0.80	0.80 ⁽³⁾	0.80 ⁽³⁾		
1.1	0.80	0.80	0.80 ⁽³⁾	0.80 ⁽³⁾		
1.2	0.80	0.80	0.80 ⁽³⁾	0.80 ⁽³⁾		
1.3	0.80	0.80	0.80 ⁽³⁾	0.80 ⁽³⁾		
1.4	0.80	0.80	0.80 ⁽³⁾	0.80 ⁽³⁾		
1.5	0.80	0.80	0.80	0.80		
1.6	0.90 ⁽²⁾	0.80	0.80	0.80		
1.7	0.95 ⁽²⁾	0.80	0.80	0.80		
1.8	1.00 ⁽²⁾	0.80	0.80	0.80		
1.9	1.05 ⁽²⁾	0.85 ⁽²⁾	0.80	0.80		
2.0	1.10 ⁽²⁾	0.90 ⁽²⁾	0.80	0.80	0.80 ⁽³⁾	0.80 ⁽³⁾
2.1	1.15 ⁽²⁾	0.95 ⁽²⁾	0.80	0.80	0.80 ⁽³⁾	0.80 ⁽³⁾
2.2	1.20 ⁽²⁾	1.00 ⁽²⁾	0.85 ⁽²⁾	0.80	0.80 ⁽³⁾	0.80 ⁽³⁾
2.3	1.25 ⁽²⁾	1.05 ⁽²⁾	0.90 ⁽²⁾	0.80	0.80 ⁽³⁾	0.80 ⁽³⁾
2.4	1.30 ⁽²⁾	1.10 ⁽²⁾	0.95 ⁽²⁾	0.80	0.80 ⁽³⁾	0.80 ⁽³⁾
2.5	1.40 ⁽²⁾	1.15 ⁽²⁾	1.00 ⁽²⁾	0.85 ⁽²⁾	0.80	0.80
2.6		1.15 ^{(2), (4)}	1.00 ⁽²⁾	0.90 ⁽²⁾	0.80	0.80
2.7		1.20 ^{(2), (4)}	1.05 ⁽²⁾	0.90 ⁽²⁾	0.80	0.80
2.8		1.25 ^{(2), (4)}	1.10 ⁽²⁾	0.95 ⁽²⁾	0.85 ⁽²⁾	0.80
2.9		1.30 ^{(2), (4)}	1.15 ⁽²⁾	1.00 ⁽²⁾	0.85 ⁽²⁾	0.80
3.0		1.35 ^{(2), (4)}	1.15 ⁽²⁾	1.00 ⁽²⁾	0.90 ⁽²⁾	0.80
3.1			1.20 ⁽²⁾	1.05 ⁽²⁾	0.95 ⁽²⁾	0.85 ⁽²⁾
3.2			1.25 ⁽²⁾	1.10 ⁽²⁾	0.95 ⁽²⁾	0.85 ⁽²⁾
3.3			1.30 ⁽²⁾	1.10 ⁽²⁾	1.00 ⁽²⁾	0.90 ⁽²⁾
3.4			1.35 ⁽²⁾	1.15 ⁽²⁾	1.00 ⁽²⁾	0.90 ⁽²⁾
3.5 ⁽¹⁾			1.35 ⁽²⁾	1.20 ⁽²⁾	1.05 ⁽²⁾	0.95 ⁽²⁾
3.6				1.20 ⁽²⁾	1.10 ⁽²⁾	0.95 ⁽²⁾
3.7				1.25 ⁽²⁾	1.10 ⁽²⁾	1.00 ⁽²⁾
3.8				1.30 ⁽²⁾	1.15 ⁽²⁾	1.05 ⁽²⁾
3.9				1.35 ⁽²⁾	1.15 ⁽²⁾	1.05 ⁽²⁾
4.0				1.35 ⁽²⁾	1.20 ⁽²⁾	1.10 ⁽²⁾
4.1					1.25 ⁽²⁾	1.10 ⁽²⁾
4.2					1.25 ⁽²⁾	1.15 ⁽²⁾
4.3					1.30 ⁽²⁾	1.15 ⁽²⁾
4.4					1.30 ⁽²⁾	1.20 ⁽²⁾
4.5					1.35 ⁽²⁾	1.20 ⁽²⁾

(1) Marpol Annex VI: Limit 3.50% sulfur content.

(2) Adjusted lubricating oil feed rate from 0.8 g/kWh to the new value.

(3) Lubricating oil feed rate setting for temporary operation (less than 48 hours).

(4) If no on-board monitoring system for PU drain oil is used, there is a 2.5% limit of sulfur content (see also 0750-1 Lubricating Oils, paragraph 3.2).

Feed Rate – Adjustment

5. Blending on Board

You can use the Wärtsilä Blending on Board (BoB) system to adjust the base number of the cylinder lubricating oil.

The system oil is used as a base oil and the correct additive package is added to make an applicable cylinder lubricating oil. The BoB system gives the best results related to the necessary neutralization and detergency properties of the cylinder lubricating oil.

You can make different BN lubricating oils on board. With an applicable cylinder lubricating oil it is not necessary to adjust the feed rate to different operation modes, i.e. the base feed rate is not changed, but the cylinder oil BN is adjusted.

Use the BoB system together with an on-board monitoring system for the PU drain oil (e.g. SEA-Mate® B2000 blender combined with the SEA-Mate® M2000 XRF analyzer) to make a correct BN lubricating oil. The correct BN improves the corrosion protection and the detergency properties of the lubricating oil.

The BoB system is most applicable for vessels that operate on a wide range of different fuel oils (related to the fuel sulfur content) and operation modes.

As a general recommendation, see the data given in Table 4. But, adjust the values as a function of the engine performance for each engine. For more data, speak to or send a message to Wärtsilä Services Switzerland Ltd.

Feed Rate – Adjustment

Table 4: BN Values Related to Sulfur Content for a Base Feed Rate of 0.8 g/kWh

Sulfur Content [%]	Usual Operation (above 60% CMCR)	Low Load Operation (below 60% CMCR)	Safeguard Operation
1.0	40	40	40
1.1	40	40	40
1.2	40	40	40
1.3	40	40	40
1.4	40	40	40
1.5	40	40	50
1.6	50	50	50
1.7	50	50	50
1.8	50	50	60
1.9	50	50	60
2.0	50	50	60
2.1	50	50	60
2.2	50	70	60
2.3	50	70	70
2.4	50	70	70
2.5	50	70	70
2.6	50	70	70
2.7	50	70	80
2.8	50	70	80
2.9	51	72	80
3.0	53	75	90
3.1	55	77	90
3.2	57	80	90
3.3	59	82	100
3.4	61	85	100
3.5	63	87	100

▽ Lubricating Oil System

- Turbocharger TPL and A100-L Type	8016-1/A3
- Turbocharger MET Type	8016-1/A4
Cooling Water System	8017-1/A1
Starting Air Diagram	8018-1/A1
Fuel System	8019-1/A1
Exhaust Waste Gate (Low-load Tuning)	8135-1/A1
Drainage System and Wash-water Piping System	8345-1/A1

Intentionally blank

Overview

1.	General	1/12
2.	Bearing and turbocharger oil system	1/12
3.	Crosshead bearing, leakage oil pipes from exhaust valves	5/12
4.	Servo oil system	7/12
5.	Servo oil system – leakage	10/12
6.	Servo oil rail – fill and pressure release	12/12

1. General

The oil pump 1 (see Fig. 'A') supplies oil at the necessary pressure for engine control, lubrication and crosshead lubricating oil pump 4 (but not cylinder lubrication). For data about the pressure values, see [0250-1](#) Operating Data Sheet.

The oil supply to the different lubricating points is shown in the schematic diagrams Fig. 'A' and Fig. 'B'.

The cylinder and exhaust valve lubrication is described in [7218-1](#).

The location of the pumps, filters, heat exchangers, etc is shown on the plant diagram, which is given in different documentation.

2. Bearing and turbocharger oil system

Bearing oil is supplied through the oil inlet pipe 5 on fuel side to the oil pipe 10 and the main bearings 9 through bores in the bearing girders.

Bearing oil is also used to cool the piston through the toggle lever 15 (for more data, see [3603-1](#) Piston Cooling and Crosshead Lubrication).

Oil flows to the exhaust valve control units through the servo oil system (see paragraph 4 and [4003-2](#) Control Diagram).

There is an oil supply through the supply pipe 18 for the bearings, nozzles, fuel pumps and internal bores in the supply unit (for more data, see [5552-1](#) Supply Unit and [5556-1](#) Fuel Pump).

From inlet pipe 5, oil also flows off to operate the fuel pressure control valve 3.06 in the fuel rail (see [8019-1](#), paragraph 3 and the Control Diagram).

The built-in axial damper 8, (and if installed, the vibration damper 26), intermediate wheels 21 and the drive supply unit are supplied and cooled with bearing oil.

The bearing oil and crosshead bearing oil systems are connected through the non-return valve 6.

Turbocharger TPL type:

Bearing oil flows through the oil inlet pipe 5 on the fuel side and oil inlet pipe 27 to the turbochargers 28. The oil flows back through the vent tank 29 (air separator built in to the scavenge air receiver) to the outlet pipe 30 and the main leakage oil collector 32 from the exhaust valve to the column.

Turbocharger A100-L type:

Bearing oil flows through oil inlet pipe 5 on fuel side and the oil inlet pipe 25 to the turbochargers 26. The oil flows back through the outlet pipe 28 to the main leakage oil collector 30.

The device (ball valves 34 and 35) used to get oil samples is installed in the outlet pipe for dirty oil 33 from the piston underside (see also [0750-1](#) Cylinder lubricating oil).



Remark: During operation, the ball valves 36 stay open and the ball valves 35 are closed.

2.1 Taking dirty oil samples

2.1.1 Preparation

- 1.) Write the applicable data on the oil analysis form (e.g. operation conditions, fuel parameters, cylinder lubricating oil feed rate etc).
- 2.) Make sure that the labels on the sample bottles refer to the related cylinders.

2.1.2 Procedure

- 1.) Close the ball valve (2) for approximately 30 minutes to 60 minutes.



Remark: Some parts can look different.

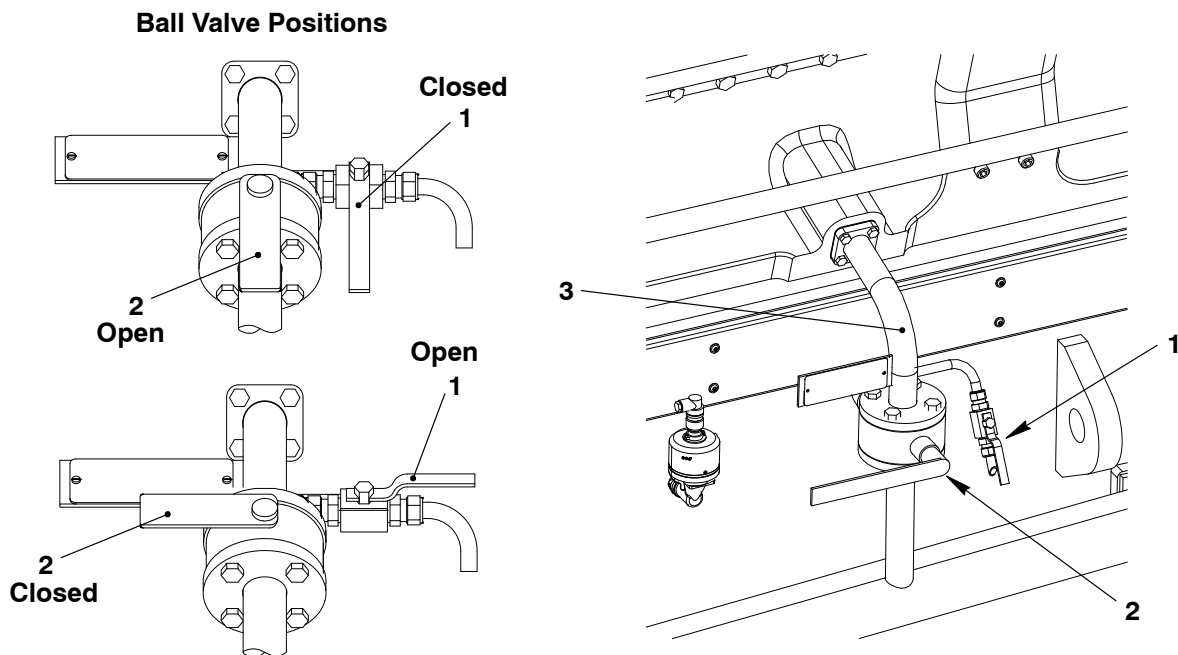

- 2.) Put an applicable container under the ball valve (1).
- 3.) Slowly open the ball valve (1) to flush out oil and possible dirt.
- 4.) Close the ball valve (1).
- 5.) Open the ball valve (2) to drain the remaining oil from the dirty oil pipe (3).
- 6.) Close the ball valve (2).
- 7.) Put the sample bottle under the ball valve (1).
- 8.) After approximately 10 minutes to 60 minutes, slowly open the ball valve (1) to fill the sample bottle.
- 9.) Close the ball valve (1).
- 10.) Open the ball valve (2) to drain the oil that collected in the dirty oil pipe (3).
- 11.) Do the steps 1) to 10) again on each cylinder.



Remark: Wäertsilä Services Switzerland Ltd. recommends that you get an oil sample of the cylinder lubricating oil downstream of the duplex filter. Send the oil sample to the laboratory to make an analysis to make sure the initial cylinder lubricating oil had the correct quality and no contamination.

- 12.) Make sure that the sample bottles are tightly closed and use an applicable package.
- 13.) Send the samples to the laboratory to make an analysis.

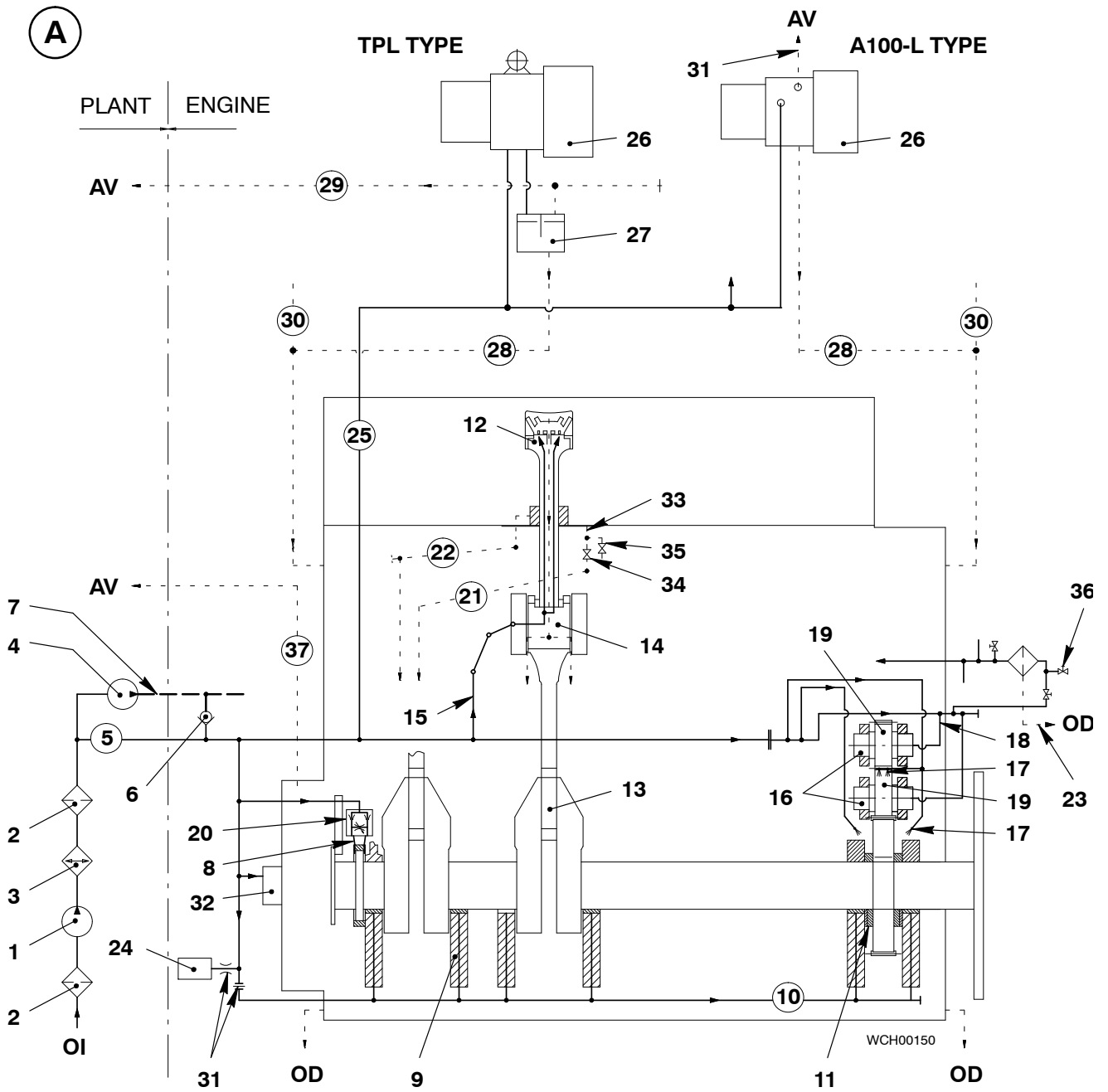

Key to Illustrations: 'A' Bearing and turbocharger oil system

- | | |
|---------------------------------------------------------------|--------------------------------------------------------|
| 1 Oil pump | 25 Oil inlet pipe |
| 2 Oil filter | 26 Turbocharger |
| 3 Oil cooler | 27 Vent tank (for TPL type only) |
| 4 Crosshead lubricating oil pump | 28 Outlet pipe |
| 5 Oil inlet pipe (fuel side) | 29 Vent pipe |
| 6 Non-return valve | 30 Main leakage oil collector
(from exhaust valves) |
| 7 Oil supply pipe, crosshead lubrication | 31 Throttle |
| 8 Axial damper | 32 Crank angle sensor unit |
| 9 Main bearing | 33 Outlet (drain) pipe for dirty oil |
| 10 Oil inlet to main bearing | 34 Ball valve |
| 11 Thrust bearing | 35 Ball valve (oil samples PU) |
| 12 Piston | 36 Ball valve (oil samples of system oil) |
| 13 Bottom end bearing | 37 Crankcase vent pipe |
| 14 Crosshead pin | |
| 15 Toggle lever (piston cooling
and crosshead lubrication) | |
| 16 Intermediate wheel bearing | |
| 17 Nozzle | |
| 18 Supply pipe | |
| 19 Intermediate wheels (top and bottom) | |
| 20 Axial damper monitor | |
| 21 Main dirty oil collector (from PU) | BO Bearing oil |
| 22 Main leakage oil collector
(from piston rod gland) | AV Air vent |
| 23 Flushing oil drain f. automatic filter | CB Crosshead bearing oil |
| 24 Vibration damper | OD to oil drain tank |
| | OI Oil inlet from oil drain tank |

BO —————**CB** - - - - -**OD** - - - - -

3. Crosshead bearing, leakage oil pipes from exhaust valves

3.1 Crosshead bearing oil system

Lubricating oil flows through the toggle levers 10 to the crosshead pins 9, then through the connecting rods to the bottom end bearings 8 (see Fig. 'B').



Remark: If the crosshead lubricating oil pump 4 becomes defective, the crosshead bearing oil system is supplied with bearing oil pressure. In these conditions, the engine can only be operated at a decreased load of 40%.

3.2 Main leakage oil collection

Leakage oil flows to the oil drain tank 'DT' through the pipes that follow:

- Leakage oil pipe 13
- Leakage oil from air spring 14 through the leakage oil return 15
- Leakage oil pipe exhaust valve 18 DE
- Leakage oil pipe exhaust valve 19 FE
- Turbocharger oil return 17
- Oil drain 16 from fuel pressure control valve 3.06

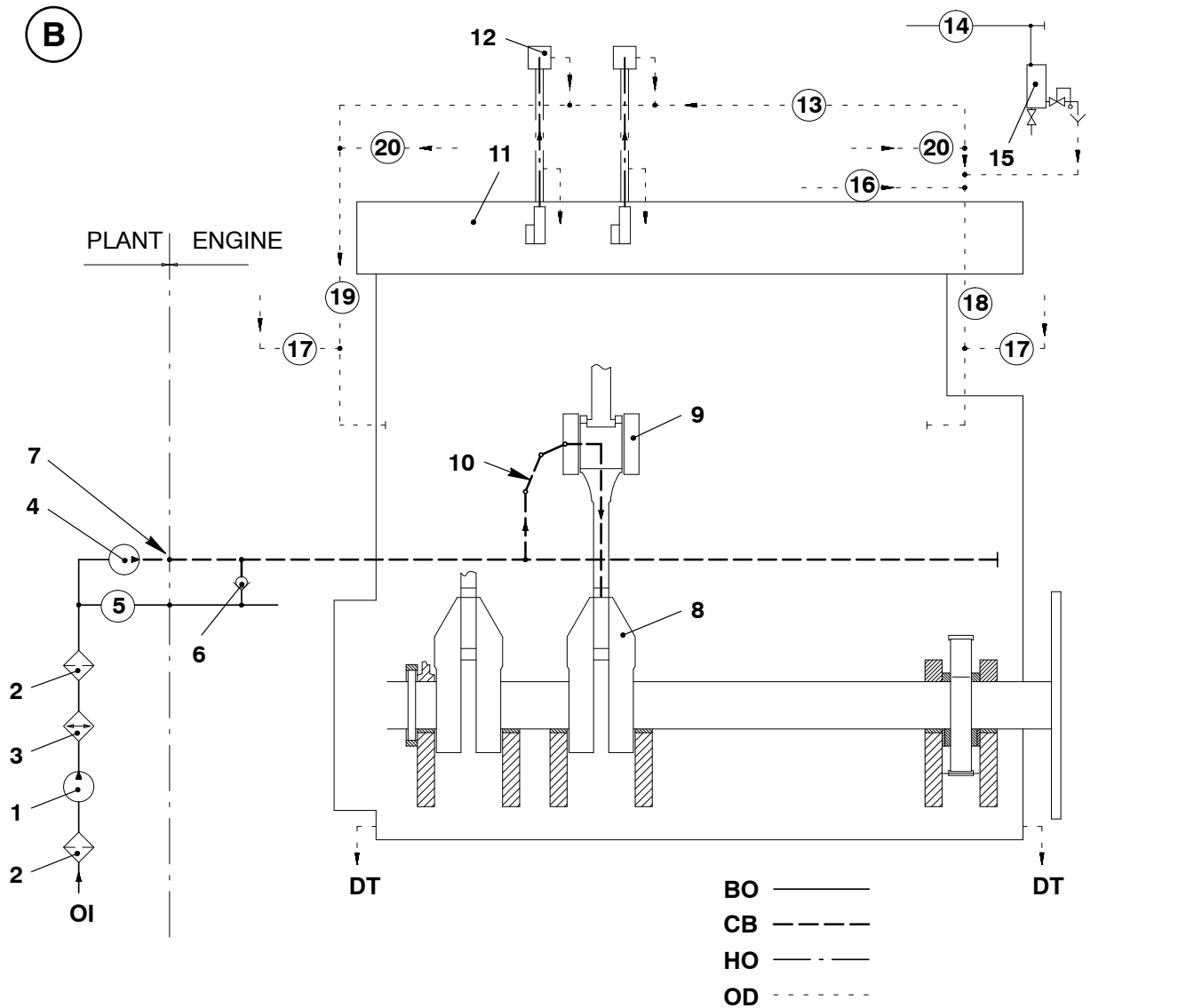

Key to Illustration: 'B' Crosshead bearing, main leakage oil collector

- | | |
|------------------------------------------|----------------------------------------|
| 1 Oil pump | 15 Leakage oil return |
| 2 Oil filter | 16 Oil drain (from |
| 3 Oil cooler | fuel pressure control valve 3.06) |
| 4 Crosshead lubricating oil pump | 17 Turbocharger oil return |
| 5 Oil inlet pipe on exhaust side | 18 Leakage oil pipe exhaust valve (DE) |
| 6 Non-return valve | 19 Leakage oil pipe exhaust valve (FE) |
| 7 Oil supply pipe, crosshead lubrication | 20 Servo oil return from cylinder |
| 8 Bottom end bearing | lubrication pumps |
| 9 Crosshead pin | |
| 10 Toggle lever | OD Drain |
| 11 Rail unit | CB Crosshead bearing oil |
| 12 Exhaust valve | BO Bearing oil |
| 13 Leakage oil pipe (from exhaust valve) | DT to oil drain tank |
| 14 Leakage oil pipe (from air spring) | OI from oil drain tank |
| | HO Hydraulic oil |

4. Servo oil system

The servo oil system controls the exhaust valve movement and the injection control units. The necessary oil flows off from the bearing oil system (see Fig. 'C').

4.1 Servo oil service pump

The electrically-driven servo oil service pump 3 must be manually set to on and off. The servo oil service pump is used to supply the necessary pressure for exhaust valve movement. The servo oil service pump is also used to do a leak test before the first commissioning, or after maintenance on the servo oil system.



Do not start the servo oil service pump if the bearing oil pump is not in operation.



Remark: The lubricating oil pump and servo oil service pump must only be set to on after the air spring air supply is available and the exhaust valves are closed.

The servo oil service pump increases the pressure in the fuel rail when necessary through the tool 94583 (pipe) (see 8019-1 High pressure circuit and 0120-1 Vent and leak test of fuel oil system on engine).

The servo oil service pump is not necessary for engine start or engine operation.



Remark: The stop valve 14 must be open before commissioning (see also 0130-1 Prepare the servo oil system).

Before engine start, make sure that the servo oil service pump is set to off.

4.2 Servo oil system

Oil flows through the automatic filter 1, the supply pipes 5 and 13 to the servo oil pumps 4.



Do not operate the engine if there is no oil supply to the servo oil service pumps. During operation, the stop valve 14 must always be open.

The servo oil pumps 4 supply oil to the servo oil rail 7 through the high pressure (HP) servo oil pipes 6. The pressure value is related to the engine load.

The leakage oil pipe is attached to the connecting block of the HP servo oil pipes (see paragraph 5).



Remark: The flow sensors 22 (installed upstream of each servo oil pump) monitor the oil supply from the servo oil pumps. If a servo oil pump becomes defective, the alarm and monitoring system (AMS) activates an alarm (see Servo Oil Pump 5551-1).

Servo oil flows from the servo oil rail 7 to the exhaust valve drive units 8 and the rail valves. The servo oil controls the movement of the exhaust valve spindle. The servo oil then flows through the flexible hose 19 to the return pipe 25 and through the column back to the plant.

Servo oil also flows from the servo oil rail 7 through the flexible hose 18 to operate the injection control units and their rail valves. The servo oil then flows through the flexible hose 19 to the return pipe 25 and through the column back to the plant.

Servo oil flows through 'CL' and operates the cylinder lubricating system at decreased pressure (for more data, see 7218-1 Cylinder Lubrication and 4003-2 Control Diagram).

(C)

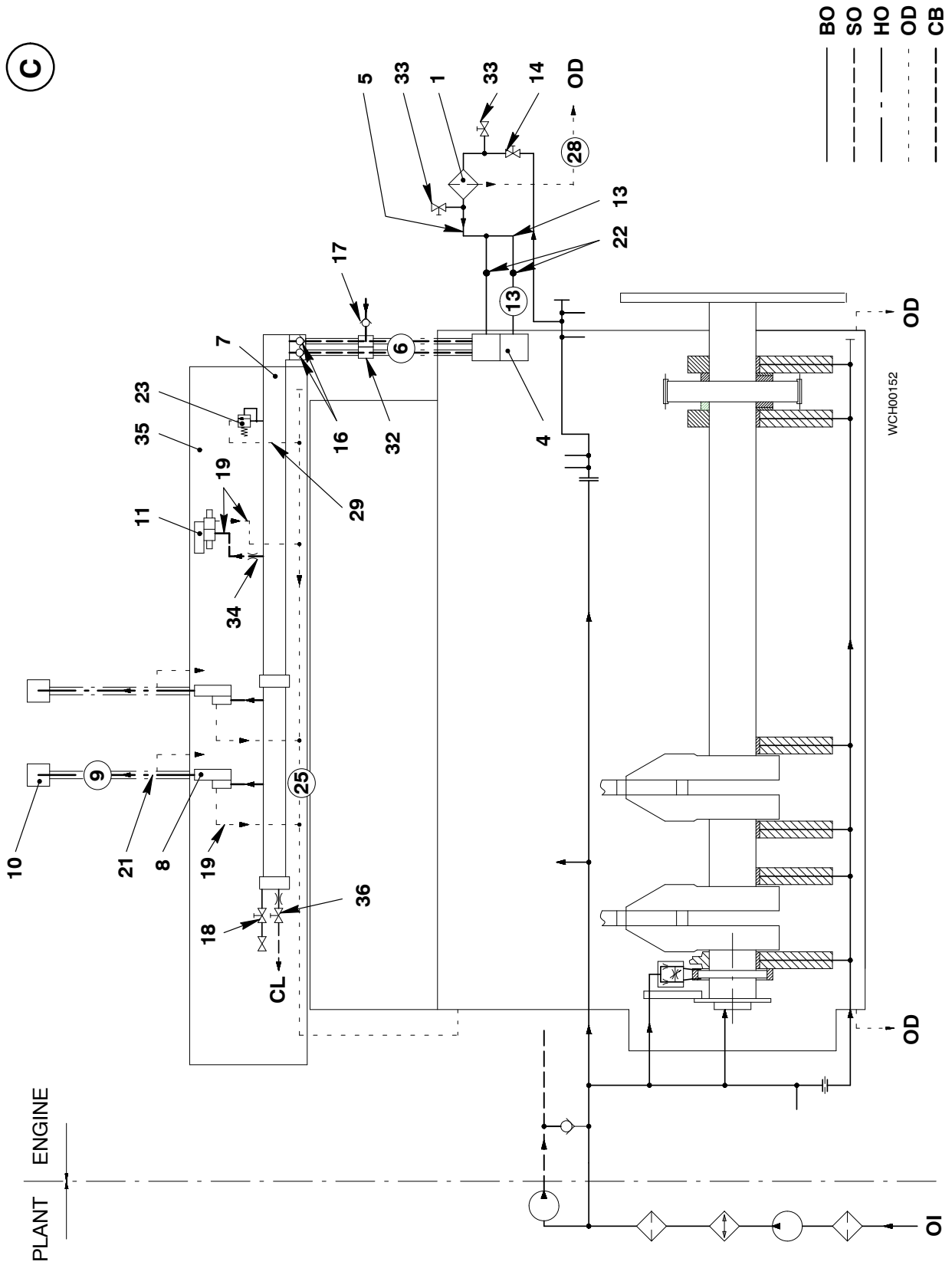

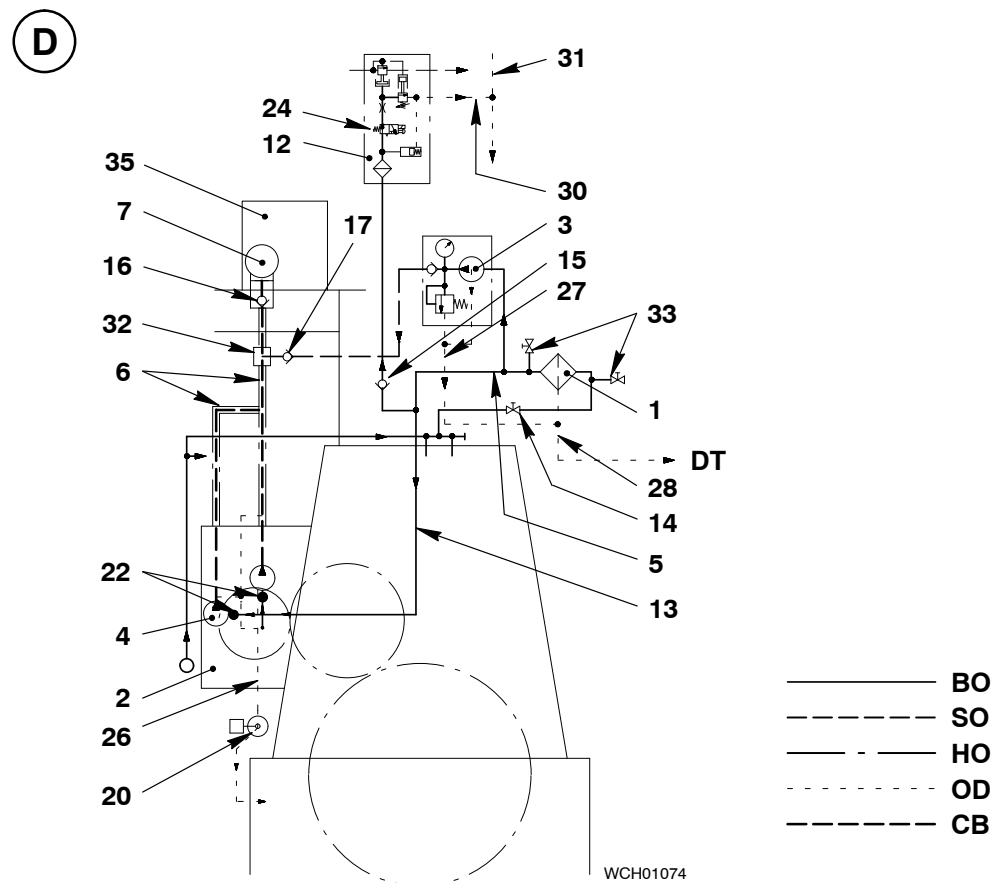

Key to Illustrations: 'C' and 'D' Servo oil system

- | | |
|----------------------------------------|--------------------------------------------------|
| 1 Automatic filter 4.20 | 23 Safety valve 4.23 |
| 2 Servo oil supply D | 24 Fuel shut-down pilot valve 3.08 |
| 3 Servo oil service pump 4.88 | 25 Servo oil return pipe 4.63 |
| 4 Servo oil pump 4.15 | 26 Leakage drain from HP servo oil pipes |
| 5 Supply pipe 4.51 | 27 Return from servo oil service pump 4.88 |
| 6 HP servo oil pipe 4.55 | 28 Flushing oil drain from automatic filter 4.20 |
| 7 Servo oil rail 4.11 | 29 Drain from safety valve 4.23 |
| 8 Exhaust valve control unit 4.10 | 30 Drain from fuel pressure control valve 3.06 |
| 9 Hydraulic pipe 4.66 | 31 Leakage oil pipe exhaust valve DE |
| 10 Exhaust valve 4.01 | 32 Connecting block |
| 11 Injection control unit 3.02 | 33 Ball valve (for oil samples) |
| 12 Fuel pressure control valve 3.06 | 34 Throttle |
| 13 Supply pipe | 35 Rail unit |
| 14 Stop valve 4.37 | 36 Stop valve 4.30-5 |
| 15 Non-return valve 3.67 | |
| 16 Non-return valves 4.24-1 and 4.24-2 | OD Drain |
| 17 Non-return valve 4.53 | HO Hydraulic oil |
| 18 Stop valve 3.40 | CB Crosshead bearing oil |
| 19 Flexible hose | BO Bearing oil |
| 20 Level switch LS2055A | DT to oil drain tank |
| 21 Leakage inspection point 4.17 | OI from oil drain tank |
| 22 Flow sensor FS2061-62A | SO Servo oil |
| | CL To cylinder lubrication |

5. Servo oil system – leakage

The level switches (LS) monitor all important leakages in the servo oil system.

If there is a large quantity of leakage oil, the related alarm is activated. See the table below:

Level switch	Monitored components
LS3444A	Monitors fuel and oil leakage from the rail unit, between exhaust valve drive unit and exhaust valve (a check bore in the cover)
LS2055A	Leakages from HP pipes

5.1 Leakage



Risk of injury! Always use gloves and safety goggles when you do work on hot components. Oil can come out as a spray when you loosen the pipe connections, and open the ball valves / stop valves.

If the level switch 9 (LS2055A) activates an alarm, the pipe connections 6 let you find the location of the leakage (see Fig. 'E'). You can then do the related procedure.

⇒ For the leakages in the HP servo oil pipes 11, do as follows:

- On the leakage oil pipe 8, carefully loosen the connections 6 a maximum of two full turns (see Fig. 'E' and Fig. 'F').

⇒ On the servo oil service pump of the related HP servo oil pipe, use the pressure controller to adjust the pressure to minimum.

If only one HP servo oil pipe is serviceable, you can operate the engine until the defective HP servo oil pipe is replaced.

You can find defective hydraulic pipes when oil flows from the check bore 'CB' in the housing of the related exhaust valve control unit 2 (for more data, see [0520-1](#) Operation with Exhaust Valve Control Unit Cut Out).

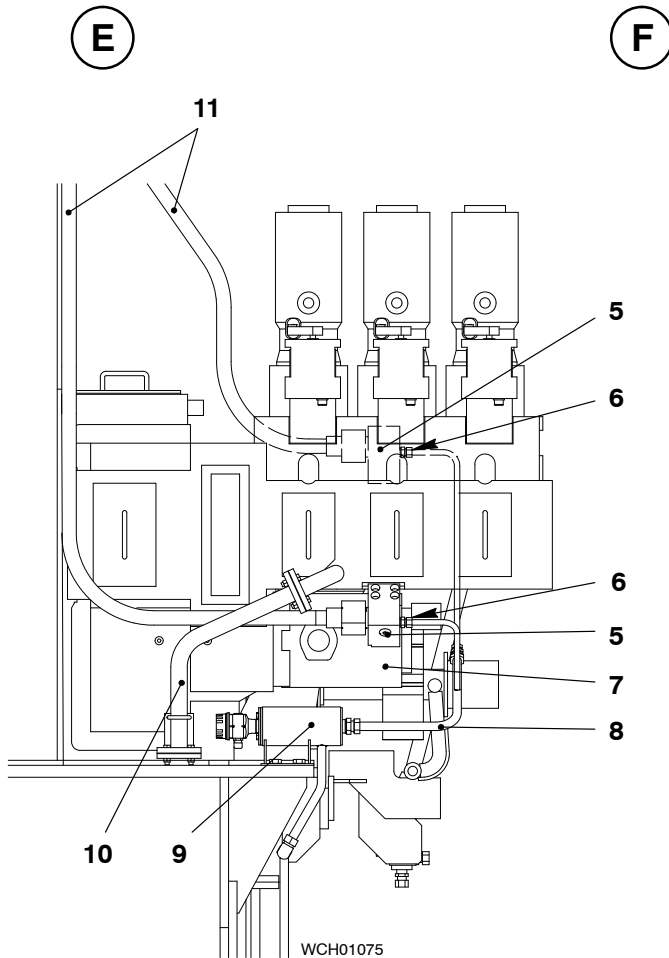

F

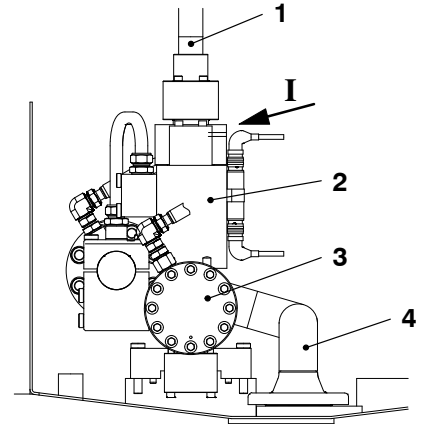

WCH01071

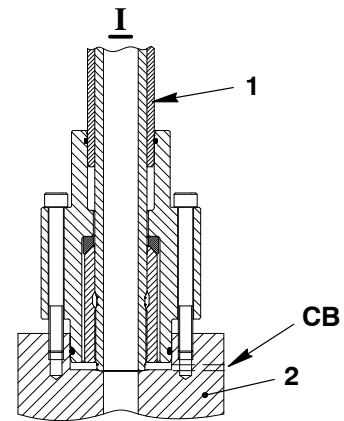

WCH01072

Key to Illustrations: 'E' Servo oil supply **D**
 'F' Exhaust valve control unit 4.10

- | | |
|-----------------------------------|----------------------------------------------|
| 1 Hydraulic pipe 4.66 | 8 Leakage oil pipe (from HP servo oil pipes) |
| 2 Exhaust valve control unit 4.10 | 9 Level switch LS2055A |
| 3 Servo oil rail 4.11 | 10 Oil drain (from supply unit) |
| 4 Servo oil return pipe 4.63 | 11 HP servo oil pipes 4.55 |
| 5 Connecting block | |
| 6 Pipe connection | |
| 7 Servo oil pump 4.15 | CB Check bore |

6. Servo oil rail – fill and pressure release

The servo oil pumps supply bearing oil to the HP servo oil pipes 6 through the automatic filter 1 (see Fig. 'C' and Fig. 'D'). The supply pressure opens the non-return valves 16 and oil flows into the servo oil rail 7. From the servo oil rail, the oil flows to the exhaust valve control units 8, through the hydraulic pipes 9 and into exhaust valve housings. Orifices release the air in the system (see also Exhaust valve 2751-1).

6.1 Fill and vent

- ⇒ Make sure that the stop valve 14 is open upstream of the automatic filter 1.
- ⇒ Make sure that the stop valve 18 in the servo oil rail 7 is closed.
- ⇒ Make sure that the plug 3 is tight (see Fig. 'G').
- ⇒ Start the bearing oil pump.



Remark: To do a function check of the exhaust valve movement, or a leak test of the servo oil system, the servo oil service pump must be set to on.

6.2 Pressure release and drain

To release the pressure and drain the servo oil rail, do the procedure that follows:

- ⇒ Remove the plug 3.
- ⇒ Carefully open the ball valve 2 to release the pressure and drain the servo oil rail 1.
- ⇒ Close the ball valve 2
- ⇒ Install the plug 3.

G

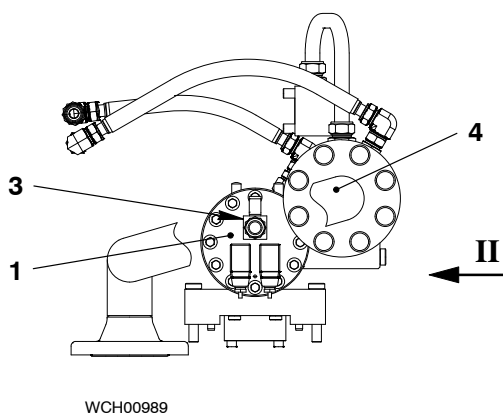

WCH00989

FREE END

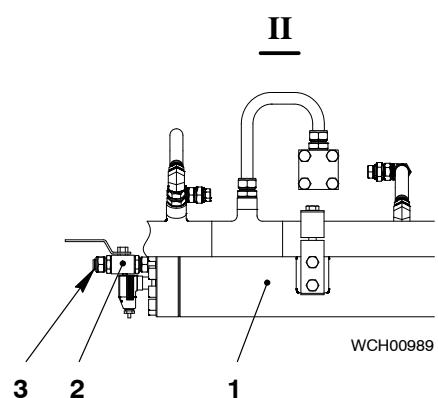

WCH00989

Key to Illustrations: 'E' Servo oil rail 4.11

- | | |
|-----------------------|------------------------------|
| 1 Servo oil rail 4.11 | 3 Plug |
| 2 Ball valve | 4 Servo oil return pipe 4.63 |

Overview

1.	General	1/12
2.	Bearing and turbocharger oil system	1/12
3.	Crosshead bearing, leakage oil pipes from exhaust valves	5/12
4.	Servo oil system	7/12
5.	Servo oil system – leakage	10/12
6.	Servo oil rail – fill and pressure release	12/12

1. General

The pump 1 supplies oil at the necessary pressure for engine control, lubrication and crosshead lubricating oil pump 4 (but not cylinder lubrication). For data about the pressure values, see [0250-1](#) Operating Data Sheet.

The oil supply to the different lubricating points is shown in the schematic diagrams Fig. 'A' and Fig. 'B'.

The cylinder and exhaust valve lubrication is described in [7218-1](#).

The configuration of the pumps, filters, heat exchangers, etc is shown on the plant diagram, which is given in different documentation.

2. Bearing and turbocharger oil system (Fig. 'A')

Bearing oil is supplied through the oil inlet pipe 5 on fuel side to the oil pipe 10 and the main bearings 9 through bores in the bearing girders.

Bearing oil is also used to cool the piston through the toggle lever 15 (for more data, see [3603-1](#) Piston Cooling and Crosshead Lubrication).

Oil flows to the exhaust valve control units through the servo oil system (see paragraph 4 and [4003-2](#) Control Diagram).

There is an oil supply through the supply pipe 18 for the bearings, nozzles, fuel pumps and internal bores in the supply unit (for more data, see [5552-1](#) Supply Unit and [5556-1](#) Fuel Pump).

From inlet pipe 5, oil also flows off to operate the fuel pressure control valve 3.06 in the fuel rail (see [8019-1](#), paragraph and the Control Diagram).

The built-in axial damper 8, (and if installed, the vibration damper 26), intermediate wheels 21 and the drive supply unit are supplied and cooled with bearing oil.

The bearing oil and crosshead bearing oil systems are connected through the non-return valve 6.

Turbocharger MET type:

Bearing oil flows through oil inlet pipe 5 on fuel side and the oil inlet pipe 25 to the turbochargers 26. The oil flows back through the outlet pipe 28 to the main leakage oil collector 30.

The device (ball valves 34 and 35) used to get oil samples is installed in the outlet pipe for dirty oil 33 from the piston underside (see also [0750-1](#) Cylinder lubricating oil).



Remark: During operation, the ball valves 34 remain open and ball valves 35 are closed.

2.1 Taking dirty oil samples

2.1.1 Preparation

- 1.) Write the applicable data on the oil analysis form (e.g. operation conditions, fuel parameters, cylinder lubricating oil feed rate etc).
- 2.) Make sure that the labels on the sample bottles refer to the related cylinders.

2.1.2 Procedure

- 1.) Close the ball valve (2) for approximately 30 minutes to 60 minutes.



Remark: Some parts can look different.

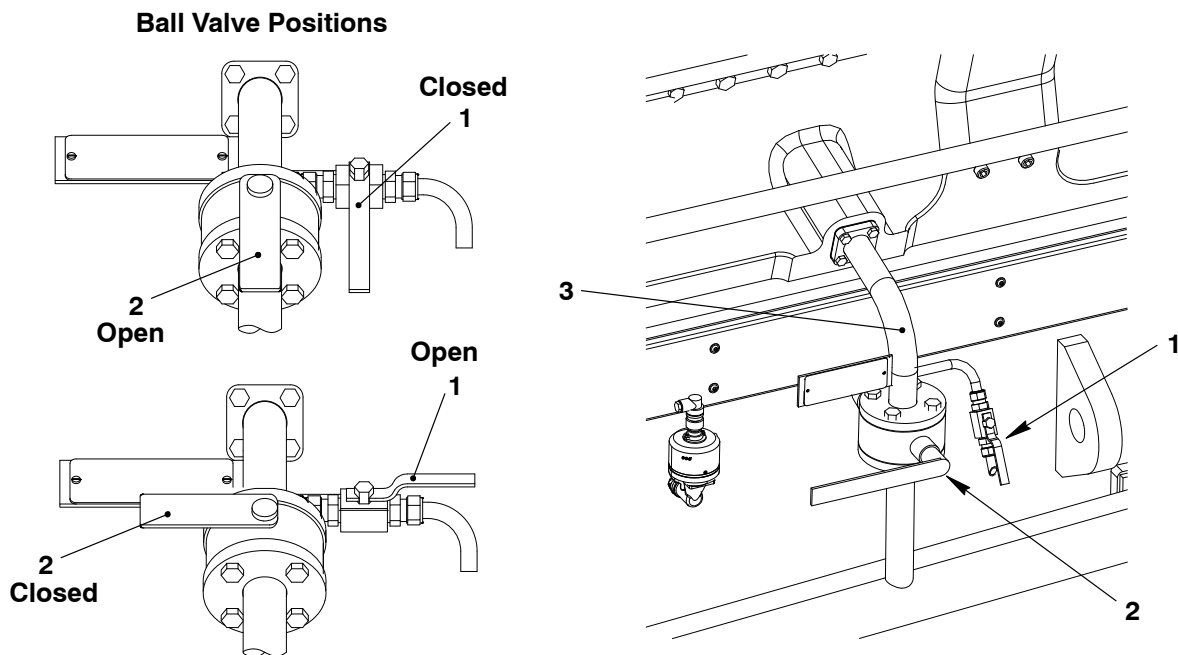

- 2.) Put an applicable container under the ball valve (1).
- 3.) Slowly open the ball valve (1) to flush out oil and possible dirt.
- 4.) Close the ball valve (1).
- 5.) Open the ball valve (2) to drain the remaining oil from the dirty oil pipe (3).
- 6.) Close the ball valve (2).
- 7.) Put the sample bottle under the ball valve (1).
- 8.) After approximately 10 minutes to 60 minutes, slowly open the ball valve (1) to fill the sample bottle.
- 9.) Close the ball valve (1).
- 10.) Open the ball valve (2) to drain the oil that collected in the dirty oil pipe (3).
- 11.) Do the steps 1) to 10) again on each cylinder.



Remark: Wäertsilä Services Switzerland Ltd. recommends that you get an oil sample of the cylinder lubricating oil downstream of the duplex filter. Send the oil sample to the laboratory to make an analysis to make sure the initial cylinder lubricating oil had the correct quality and no contamination.

- 12.) Make sure that the sample bottles are tightly closed and use an applicable package.
- 13.) Send the samples to the laboratory to make an analysis.

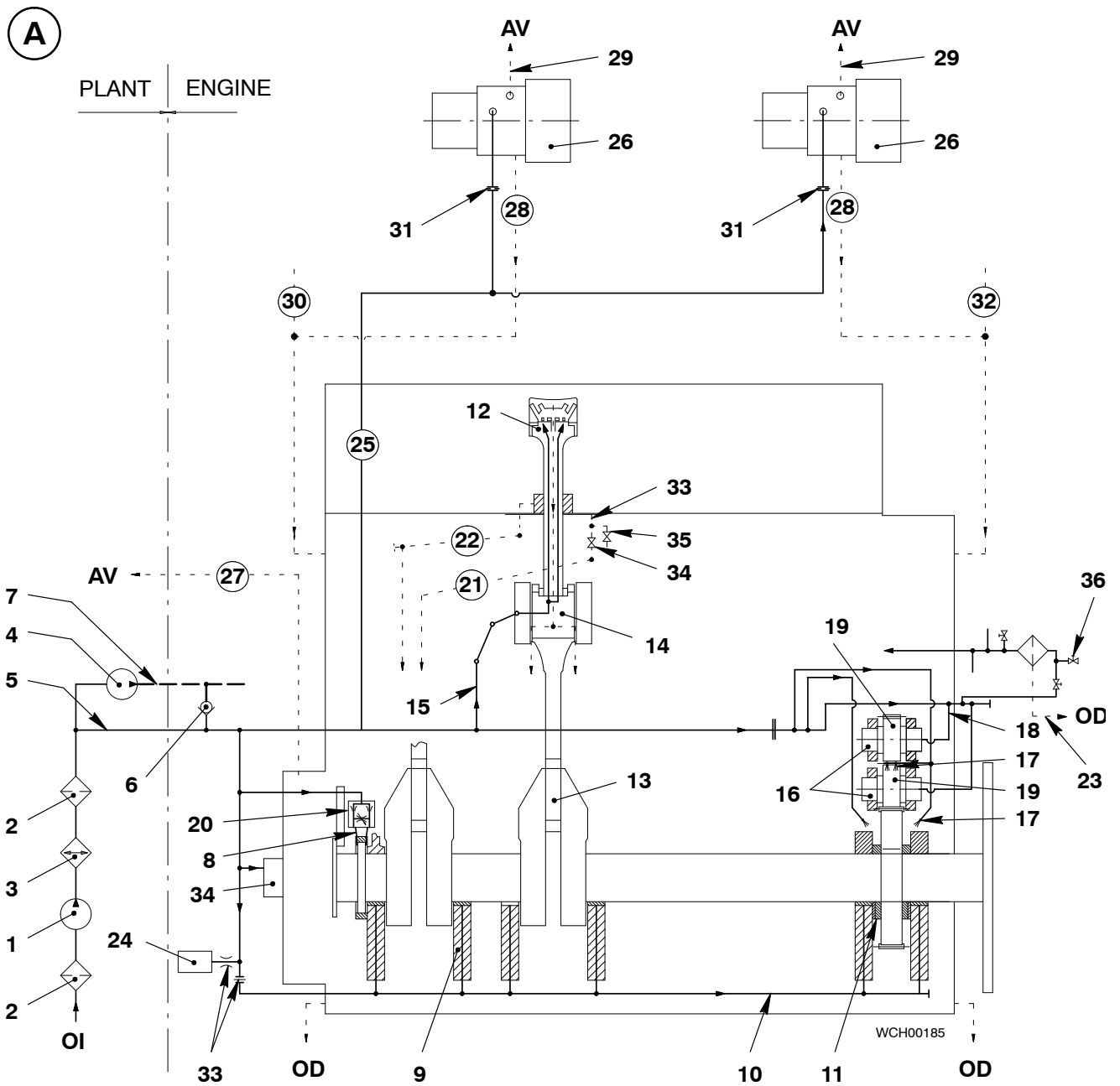

Key to Illustrations: 'A' Bearing and turbocharger oil system

1 Oil pump	25 Oil inlet pipe
2 Oil filter	26 Turbocharger
3 Oil cooler	27 Outlet pipe
4 Crosshead lubricating oil pump	28 Vent pipe
5 Oil inlet pipe (fuel side)	29 Main leakage oil collector (from exhaust valves)
6 Non-return valve	30 Throttle
7 Oil supply pipe, crosshead lubrication	31 Crank angle sensor unit
8 Axial damper	32 Outlet (drain) pipe for dirty oil
9 Main bearing	33 Ball valve
10 Oil inlet to main bearing	34 Ball valve (oil samples PU)
11 Thrust bearing	35 Ball valve (oil samples of system oil)
12 Piston	36 Crankcase vent pipe
13 Bottom end bearing	
14 Crosshead pin	
15 Toggle lever (piston cooling and crosshead lubrication)	
16 Intermediate wheel bearing	
17 Nozzle	
18 Supply pipe	
19 Intermediate wheels (top and bottom)	
20 Axial damper monitor	
21 Main dirty oil collector (from PU)	
22 Main leakage oil collector (from piston rod gland)	AV Air vent
23 Flushing oil drain f. automatic filter	CB Crosshead bearing oil to oil drain tank
24 Vibration damper	OI Oil inlet from oil drain tank
	BO ————
	CB - - - - -
	OD - - - - -

3. Crosshead bearing, leakage oil pipes from exhaust valves

3.1 Crosshead bearing oil system

Lubricating oil flows through the toggle levers 10 to the crosshead pins 9, then through the connecting rods to the bottom end bearings 8 (see Fig. 'B').



Remark: If the crosshead lubricating oil pump 4 becomes defective, the crosshead bearing oil system is supplied with bearing oil pressure. In these conditions, the engine can only be operated at a decreased load of 40%.

3.2 Main leakage oil collection

Leakage oil flows to the oil drain tank 'DT' through the pipes that follow:

- Leakage oil pipe 13
- Leakage oil from air spring 14 through the leakage oil return 15
- Leakage oil pipe exhaust valve 18 DE
- Leakage oil pipe exhaust valve 19 FE
- Oil drain 16 from fuel pressure control valve 3.06

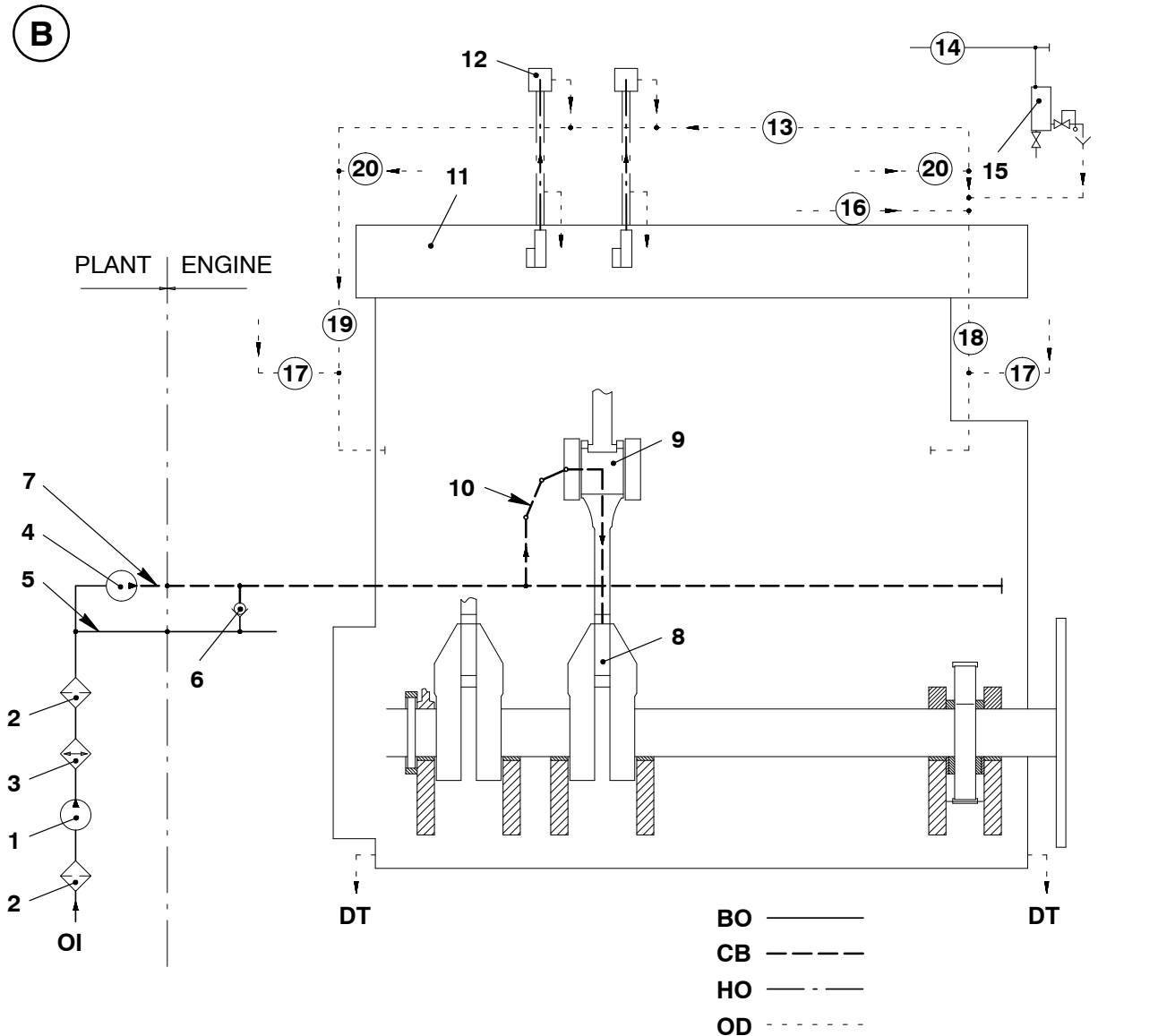

Key to Illustration: 'B' Crosshead bearing, main leakage oil collector

- | | |
|------------------------------------------|------------------------------------------------------|
| 1 Oil pump | 15 Leakage oil return |
| 2 Oil filter | 16 Oil drain (from fuel pressure control valve 3.06) |
| 3 Oil cooler | 17 Turbocharger oil return |
| 4 Crosshead lubricating oil pump | 18 Leakage oil pipe exhaust valve (DE) |
| 5 Oil inlet pipe on exhaust side | 19 Leakage oil pipe exhaust valve (FE) |
| 6 Non-return valve | 20 Servo oil return from cylinder lubrication pumps |
| 7 Oil supply pipe, crosshead lubrication | |
| 8 Bottom end bearing | |
| 9 Crosshead pin | |
| 10 Toggle lever | OD Drain |
| 11 Rail unit | CB Crosshead bearing oil |
| 12 Exhaust valve | BO Bearing oil |
| 13 Leakage oil pipe (from exhaust valve) | DT to oil drain tank |
| 14 Leakage oil pipe (from air spring) | OI from oil drain tank |
| | HO Hydraulic oil |

4. Servo oil system

The servo oil system controls the exhaust valve movement and the injection control units. The necessary oil flows off from the bearing oil system (see Fig. 'C').

4.1 Servo oil service pump

The electrically-driven servo oil service pump 3 must be manually set to on and off. The servo oil service pump is used to supply the necessary pressure for exhaust valve movement. The servo oil service pump is also used to do a leak test before the first commissioning, or after maintenance on the servo oil system.



Do not start the servo oil service pump if the bearing oil pump is not in operation.



Remark: The lubricating oil pump and servo oil service pump must only be set to on after the air spring air supply is available and the exhaust valves are closed.

The servo oil service pump increases the pressure in the fuel rail when necessary through the tool 94583 (pipe) (see 8019-1 High pressure circuit and 0120-1 Vent and leak test of fuel oil system on engine).

The servo oil service pump is not necessary for engine start or engine operation.



Remark: The stop valve 14 must be open before commissioning (see also 0130-1 Checks to be carried out on servo oil system).

Before engine start, make sure that the servo oil service pump is set to off.

4.2 Servo oil system

Oil flows through the automatic filter 1, the supply pipes 5 and 13 to the servo oil service pumps 4.



Do not operate the engine if there is no oil supply to the servo oil service pumps. During operation, the stop valve 14 must always be open.

The servo oil pumps 4 supply oil to the servo oil rail 7 through the high pressure (HP) servo oil pipes 6. The pressure value is related to the engine load.

The leakage oil pipe is attached to the connecting block of the HP servo oil pipes (see paragraph 5).



Remark: The flow sensors 22 (installed upstream of each servo oil service pump) monitor the the oil supply from the servo oil service pumps. If a servo oil service pump becomes defective, the alarm and monitoring system (AMS) activates an alarm (see Servo Oil Pump 5551-1).

Servo oil flows from the servo oil rail 7 to the exhaust valve drive units 8 and the rail valves. The servo oil controls the movement of the exhaust valve spindle. The servo oil then flows through the flexible hose 19 to the return pipe 25 and through the column back to the plant.

Servo oil also flows from the servo oil rail 7 through the flexible hose 18 to operate the injection control units and their rail valves. The servo oil then flows through the flexible hose 19 to the return pipe 25 and through the column back to the plant.

Servo oil flows through 'CL' and operates the cylinder lubricating system at decreased pressure (for more data, see 7218-1 and 4003-2 Control Diagram).

(C)

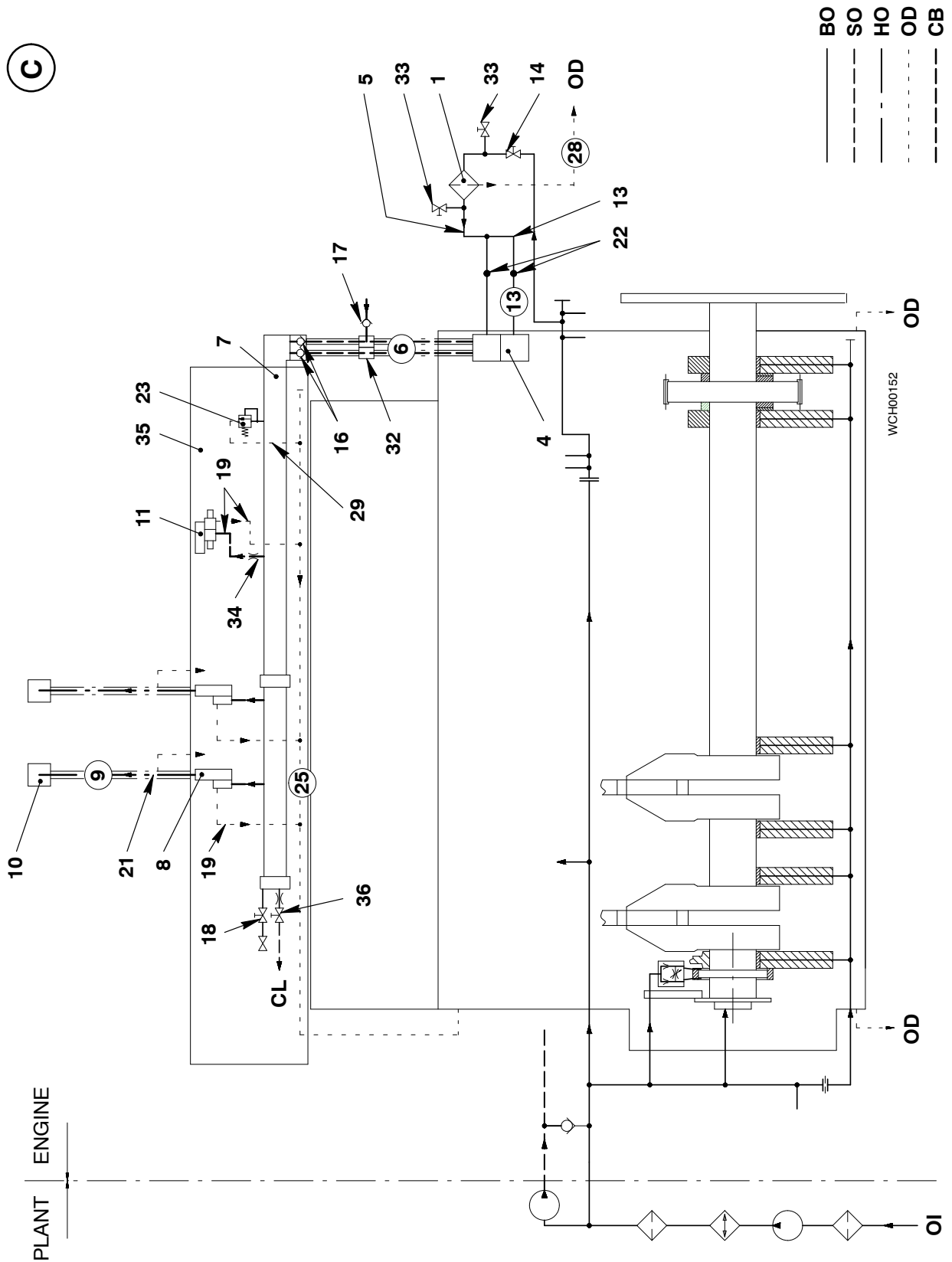

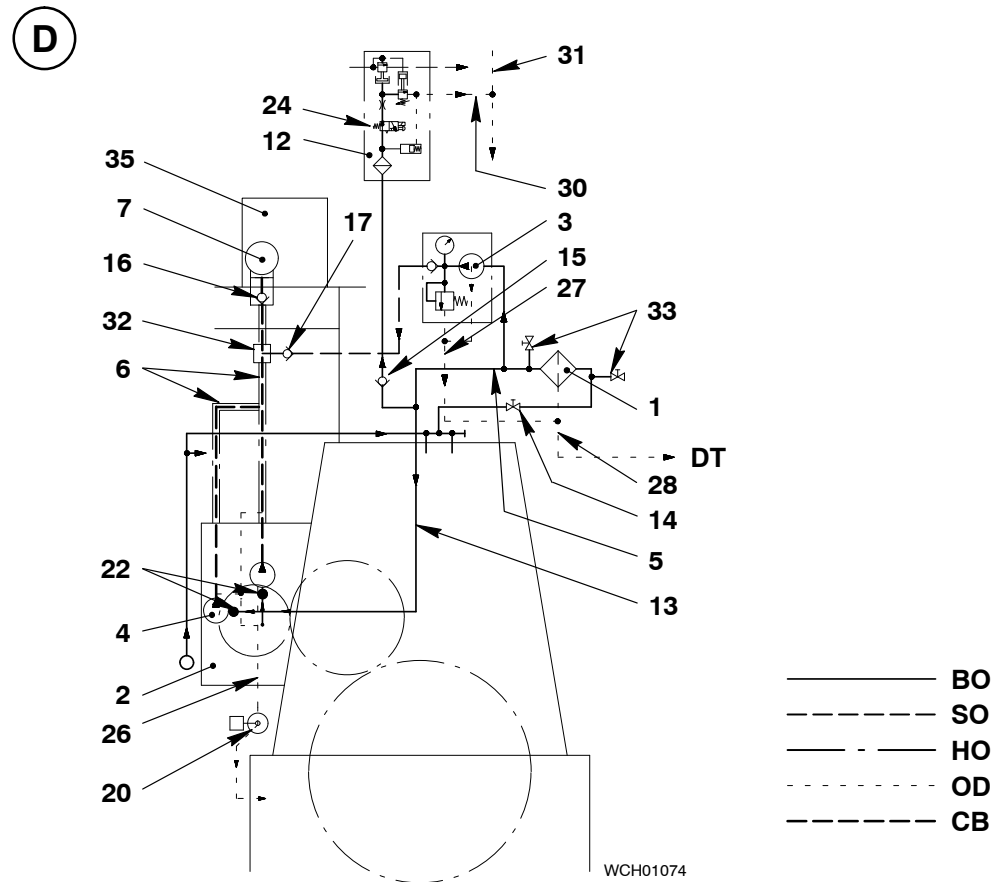

Key to Illustrations: 'C' and 'D' Servo oil system

- | | |
|----------------------------------------|--------------------------------------------------|
| 1 Automatic filter 4.20 | 23 Safety valve 4.23 |
| 2 Servo oil supply D | 24 Fuel shut-down pilot valve 3.08 |
| 3 Servo oil service pump 4.88 | 25 Servo oil return pipe 4.63 |
| 4 Servo oil pump 4.15 | 26 Leakage drain from HP servo oil pipes |
| 5 Supply pipe 4.51 | 27 Return from servo oil service pump 4.88 |
| 6 HP servo oil pipe 4.55 | 28 Flushing oil drain from automatic filter 4.20 |
| 7 Servo oil rail 4.11 | 29 Drain from safety valve 4.23 |
| 8 Exhaust valve control unit 4.10 | 30 Drain from fuel pressure control valve 3.06 |
| 9 Hydraulic pipe 4.66 | 31 Leakage oil pipe exhaust valve DE |
| 10 Exhaust valve 4.01 | 32 Connecting block |
| 11 Injection control unit 3.02 | 33 Ball valve (for oil samples) |
| 12 Fuel pressure control valve 3.06 | 34 Throttle |
| 13 Supply pipe | 35 Rail unit |
| 14 Stop valve 4.37 | 36 Stop valve 4.30-5 |
| 15 Non-return valve 3.67 | |
| 16 Non-return valves 4.24-1 and 4.24-2 | OC Drain |
| 17 Non-return valve 4.53 | HO Hydraulic oil |
| 18 Stop valve 3.40 | CB Crosshead bearing oil |
| 19 Flexible hose | BO Bearing oil |
| 20 Level switch LS2055A | DT to oil drain tank |
| 21 Leakage inspection point 4.17 | OI from oil drain tank |
| 22 Flow sensor FS2061-62A | SO Servo oil |
| | CL To cylinder lubrication |

5. Servo oil system – leakage

The level switches (LS) monitor all important leakages in the servo oil system.

If there is a large quantity of leakage oil, the related alarm is activated. See the table below:

Level switch	Monitored components
LS3444A	Monitors fuel and oil leakage from the rail unit, between exhaust valve drive unit and exhaust valve (a check bore in the cover)
LS2055A	Leakages from HP pipes

5.1 Leakage



Risk of injury! Always use gloves and safety goggles when you do work on hot components. Oil can come out as a spray when you loosen the pipe connections, and open the ball valves / stop valves.

If the level switch 9 (LS2055A) activates an alarm, the pipe connections 6 let you find the location of the leakage (see Fig. 'E'). You can then do the related procedure.

⇒ For the leakages in the HP servo oil pipes 11, do as follows:

- On the leakage oil pipe 8, carefully loosen the connections 6 a maximum of two full turns (see Fig. 'E' and Fig. 'F').
- ⇒ On the servo oil service pump of the related HP servo oil pipe, use the pressure controller to adjust the pressure to minimum.

If only one HP servo oil pipe is serviceable, you can operate the engine until the defective HP servo oil pipe is replaced.

You can find defective hydraulic pipes when oil flows from the check bore 'CB' in the housing of the related exhaust valve control unit 2 (for more data, see [0520-1 Operation with Exhaust Valve Control Unit Cut Out](#)).

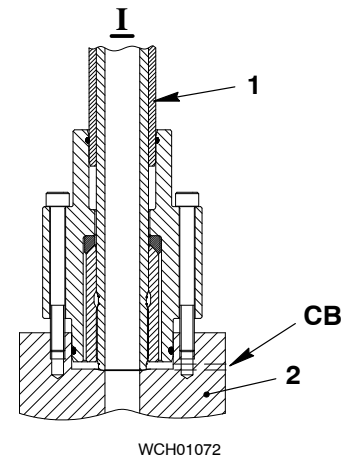
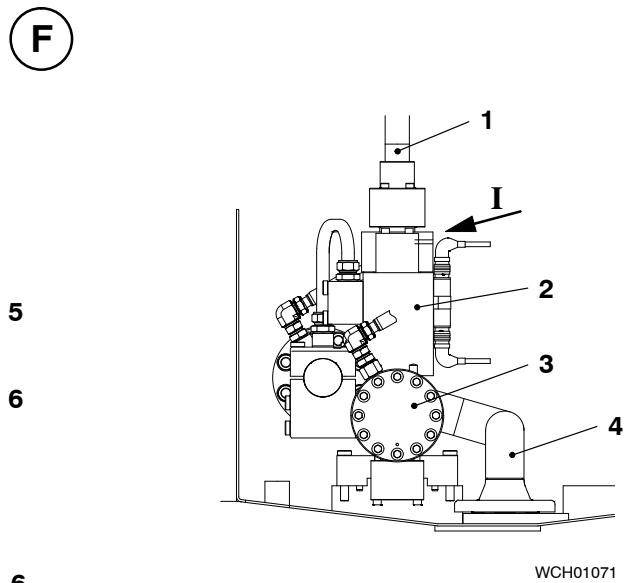
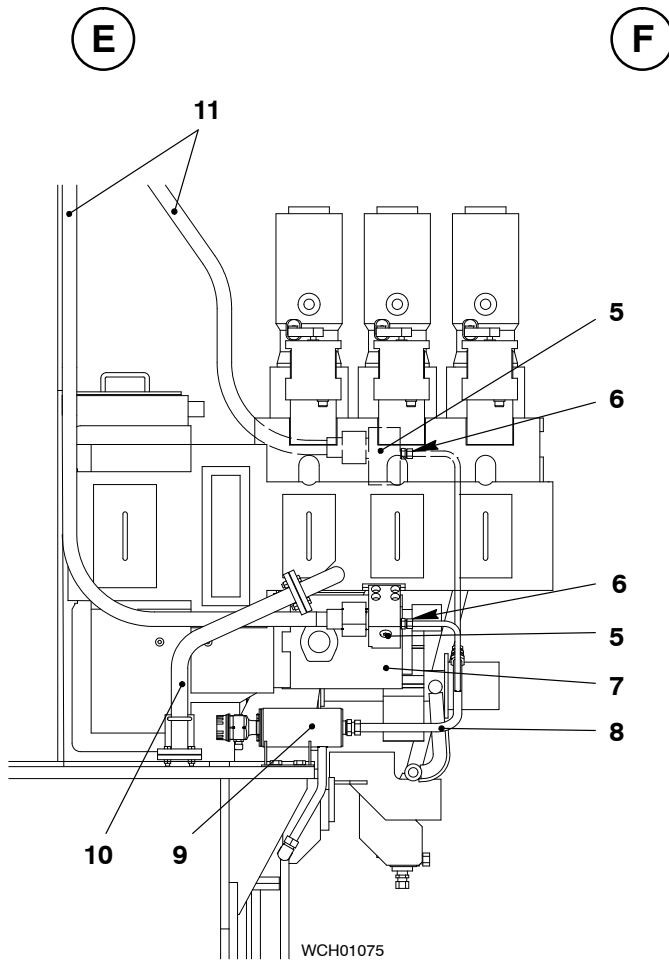

Key to Illustrations: 'E' Servo oil supply **D**
 'F' Exhaust valve control unit 4.10

- | | |
|-----------------------------------|----------------------------------------------|
| 1 Hydraulic pipe 4.66 | 8 Leakage oil pipe (from HP servo oil pipes) |
| 2 Exhaust valve control unit 4.10 | 9 Level switch LS2055A |
| 3 Servo oil rail 4.11 | 10 Oil drain (from supply unit) |
| 4 Servo oil return pipe 4.63 | 11 HP servo oil pipes 4.55 |
| 5 Connecting block | |
| 6 Pipe connection | |
| 7 Servo oil pump 4.15 | CB Check bore |

6. Servo oil rail – fill and pressure release

The servo oil pumps supply bearing oil to the HP servo oil pipes 6 through the automatic filter 1 (see Fig. 'C' and Fig. 'D'). The supply pressure opens the non-return valves 16 and oil flows into the servo oil rail 7. From the servo oil rail, the oil flows to the exhaust valve control units 8, through the hydraulic pipes 9 and into exhaust valve housings. Orifices release the air in the system (see also Exhaust valve 2751-1).

6.1 Fill and vent

- ⇒ Make sure that the stop valve 14 is open upstream of the automatic filter 1.
- ⇒ Make sure that the stop valve 18 in the servo oil rail 7 is closed.
- ⇒ Make sure that the plug 3 is tight (see Fig. 'G').
- ⇒ Start the bearing oil pump.



Remark: To do a function check of the exhaust valve movement, or a leak test of the servo oil system, the servo oil service pump must be set to on.

6.2 Pressure release and drain

To release the pressure and drain the servo oil rail, do the procedure that follows:

- ⇒ Remove the plug 3.
- ⇒ Carefully open the ball valve 2 to release the pressure and drain the servo oil rail 1.
- ⇒ Close the ball valve 2
- ⇒ Install the plug 3.

G

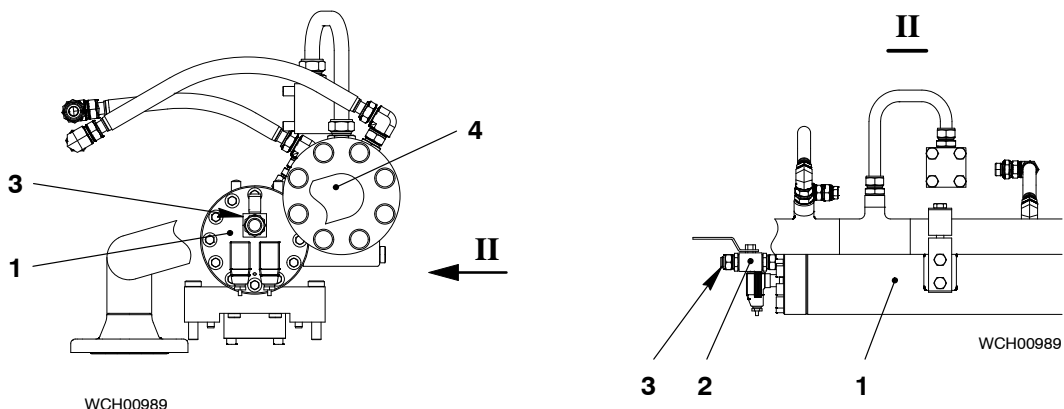

FREE END

Key to Illustrations: 'E' Servo oil rail 4.11

- | | |
|-----------------------|------------------------------|
| 1 Servo oil rail 4.11 | 3 Plug |
| 2 Ball valve | 4 Servo oil return pipe 4.63 |

Cooling Water System

1. General

The schematic diagram (Fig. 'A') shows the cooling water system on the engine.

The location of pumps, coolers, fresh water generator, heater, expansion tank, valves and throttling discs for flow control etc. are found in the separate documentation for the plant layout (shipyard side). Also the layouts of raw water for the scavenge air, lubricating oil and jacket cooling water coolers are shown in the layout diagram.

The cooling water system is a closed circuit and connected to an expansion tank in the plant. The cooling water, keeps cool the cylinder liners, cylinder covers and exhaust valve cages.

In order to bring the cooling water to operating temperature even before the engine has started a cooling water heater is installed in the plant.

The cooling water must be treated with an approved inhibitor to prevent corrosive attack, sludge formation and scale deposits in the system (see Cooling Water / Cooling Water Treatment 0760-1).



Attention! If the engine is out of operation for a long period in cold/frosty conditions, you must drain the cooling water system. The water is chemically treated and you must decontaminate the water in accordance with local environmental regulations. To fill the system again, see the Cooling Water / Cooling Water Treatment 0760-1.

Automatic cooling water temperature control:

Keep the temperature of the cooling water outlet temperature as stable as possible during all load conditions. This will prevent too much expansion and contraction of the combustion chamber components e.g. cylinder liners and cylinder covers.

- $\pm 2^{\circ}\text{C}$ at constant load
- $\pm 4^{\circ}\text{C}$ during load changes (transient conditions)

For data about pressures, temperature ranges, alarm and safety setting points, see Operating Data Sheets 0250-1 and 0250-2.

Cooling Water System

2. Function

The cooling water pump supplies cooling water, through the supply pipe 6 on the exhaust side, to the cylinders. The cooling water flows through the cylinder liner 11, water guide jacket 12, cylinder cover 13 and exhaust valve cage 14.

You can use the shut-off valves 5 and 7 to isolate and drain each cylinder from the cooling water system. A vent pipe 2 is connected to an expansion tank and the main outlet connector 1. The cooling water system continuously vents.

The water flows from the cylinder cooling water outlet 3 through the adjustable throttle 3 and a temperature regulating valve to the cooler and back to the pump. A balance pipe connects the suction side of the pump to the expansion tank. This balance pipe makes sure there is static pressure and also adjusts for the expansion and decrease of water.

A throttle 15 is installed in the outlet pipe of each cylinder. The throttle controls the flow rate of cooling water through the cylinder.

The adjustable throttle 4, installed in the cylinder cooling water outlet 3, controls the pressure in the system.

Cooling Water System

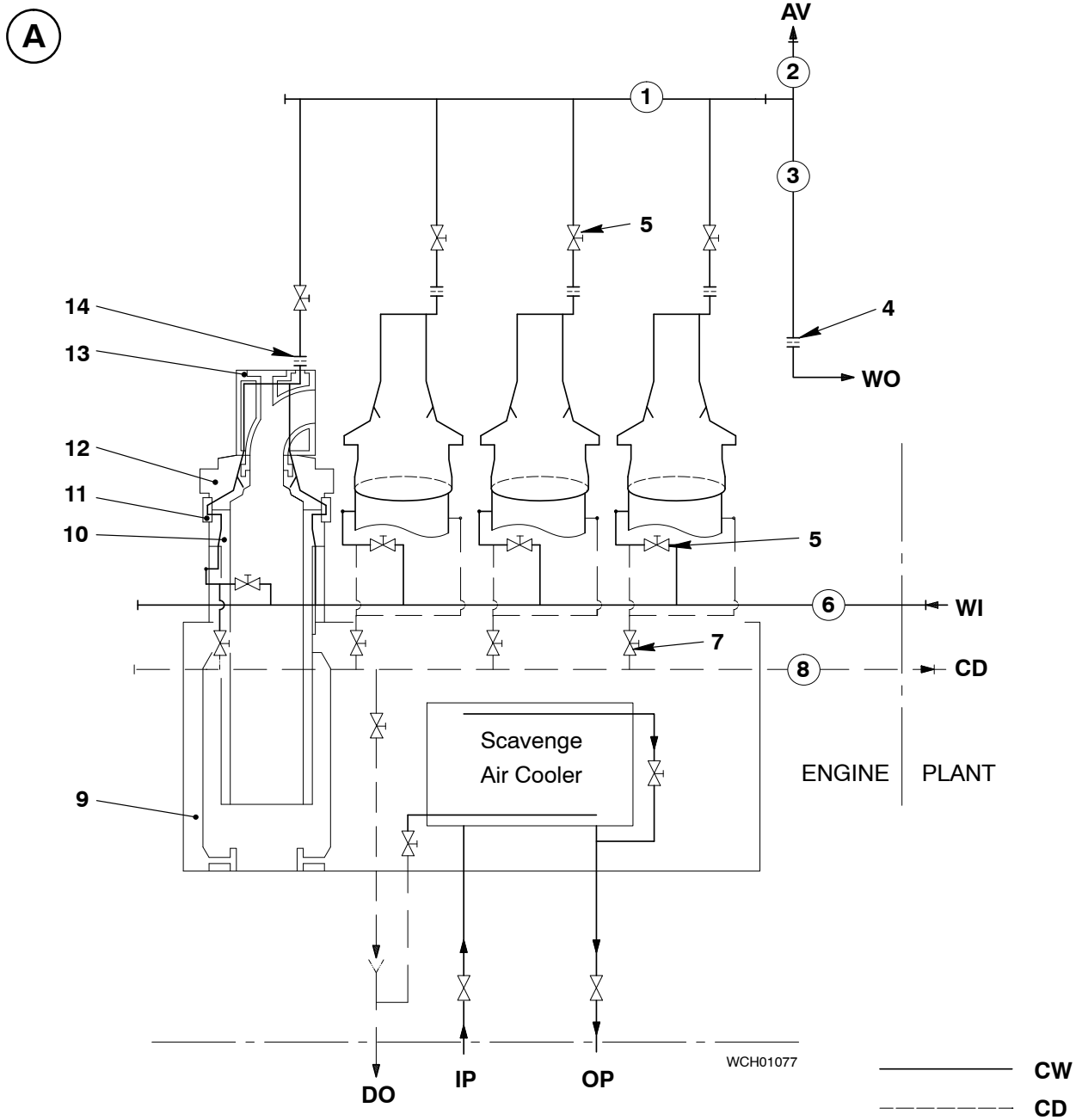

Key:

- | | |
|-------------------------------------|------------------------------|
| 1 Main collector outlet | 12 Cylinder cover |
| 2 Vent pipe | 13 Exhaust valve cage |
| 3 Cylinder cooling water outlet | 14 Throttle, cylinder outlet |
| 4 Adjustable throttle, water outlet | |
| 5 Shut-off valve at cylinder | |
| 6 Supply pipe | |
| 7 Shut-off valve (cylinder drain) | AV Air vent |
| 8 Cooling water drain | CW Cooling water |
| 9 Cylinder block | WO Cooling water outlet |
| 10 Cylinder liner | WI Cooling water inlet |
| 11 Water guide jacket | CD Cylinder drain |

Intentionally blank

Starting Air Diagram

1. General

The configuration of the starting air system is shown on the schematic diagram below.

The control air supply unit 6 and the control air bottle 5 supply the air necessary for engine control. For more data about the control air system, see 4003-2 Control Diagram and 4003-3 Control and Auxiliary Systems.

The compressed air must be clean and dry.

You must open the drain valves at regular intervals to remove condensation from the starting air system. For more data about the starting air venting, see 0320-1, Procedures after Engine Stop, paragraph 1.2.

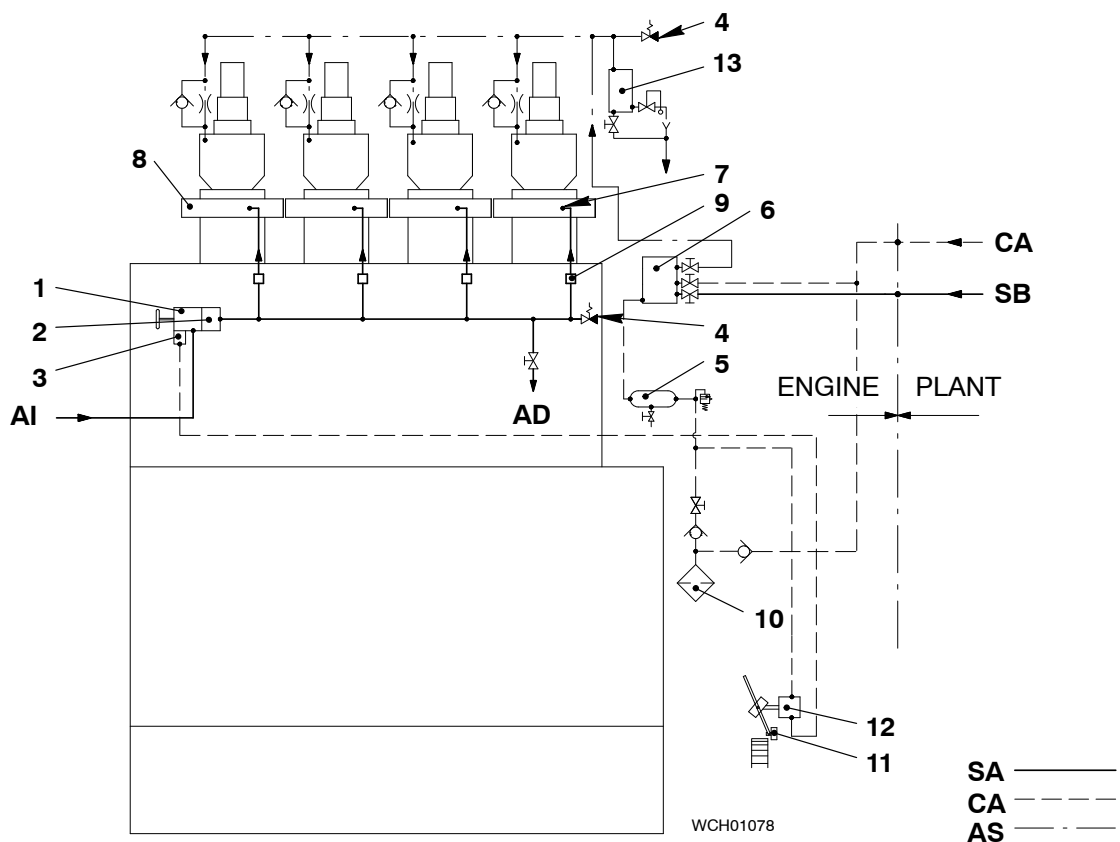

Key to illustration:

- | | |
|---------------------------------------------------|-----------------------------------------------|
| 1 Shut-off valve for starting air | 12 3/2-way valve on turning gear |
| 2 Non-return valve | 13 Oil leakage return from air spring |
| 3 Control valve and valve unit for start E | |
| 4 Safety valve | |
| 5 Air bottle (control air supply unit) A | SA Starting air |
| 6 Control air supply unit A | AI Starting air inlet |
| 7 Starting valve | AD Air drain |
| 8 Cylinder cover | CA Control air (board supply) 7 bar to 9 bar |
| 9 Flame arrester | AS Air spring air |
| 10 Automatic fine filter | SB Starting air 30 bar and safety control air |
| 11 Turning gear | |

Intentionally blank

Fuel System

1. General

For heavy fuel operation, the heating system is used to keep the engine warm during operation and for a short engine stop. All the pipes to the injection control units 13 (see Fig. 'A') have heating pipes and applicable insulation.

For safety, the fuel rail is installed in the rail unit 30. All the pipes in the high pressure circuit outside the rail unit casing have double-walls.

2. Low pressure circuit

A booster pump installed in the plant supplies fuel through the fuel inlet pipe 1 to the fuel pumps 3. The fuel quantity supplied is more than necessary for the engine. The pressure retaining valve 6 adjusts the booster pressure to the specified setting. Unwanted fuel flows back to the system through the fuel outlet pipe 4.

2.1 Setting the pressure retaining valve

The fuel pressure values must be adjusted in accordance with the indications in Operating Data Sheet [0250-1](#) for 'fuel pump inlet' and 'fuel pump return' (downstream of the pressure retaining valve).

When the spindle 31 is turned in a clockwise direction (+), the pressure is increased. When the spindle is turned in a counterclockwise direction (-), the pressure is decreased. The pressures are shown on the pressure gauges 7. The two locknuts 32, 33 must be loosened before the spindle can be adjusted (see 'Fig. B').

If it is necessary to drain the low pressure circuit (i.e. for fuel pump removal), use the screw plugs 34 (see Fig. 'A' and Fig. 'E').

3. High pressure circuit

Before the first commissioning, or after maintenance on the high pressure circuit, the tool 94583 (pipe) can be connected between the fuel rail 12 and the servo oil rail (4.11) (see Fig. 'A'). The servo oil service pump supplies the necessary pressure through the servo oil system for a leak test and quick vent of the high pressure circuit (see [0120-1](#) 'Venting and leak test of fuel system on the engine').

The fuel pumps 3 supply fuel through the high pressure (HP) fuel pipes 8 into the fuel rail. The fuel pumps supply sufficient fuel to keep the necessary pressure in the fuel rail (see Fuel Pump [5556-1](#)).

The injection control units 13 control the fuel injection volume to each injection valve 15.

The non-return valves 9, 10 or 11 prevent a pressure decrease in the fuel rail if there is damage that lets fuel come out as a spray from the HP fuel pipe 8 (see paragraph 4, Fuel leakage system).

Fuel System

A

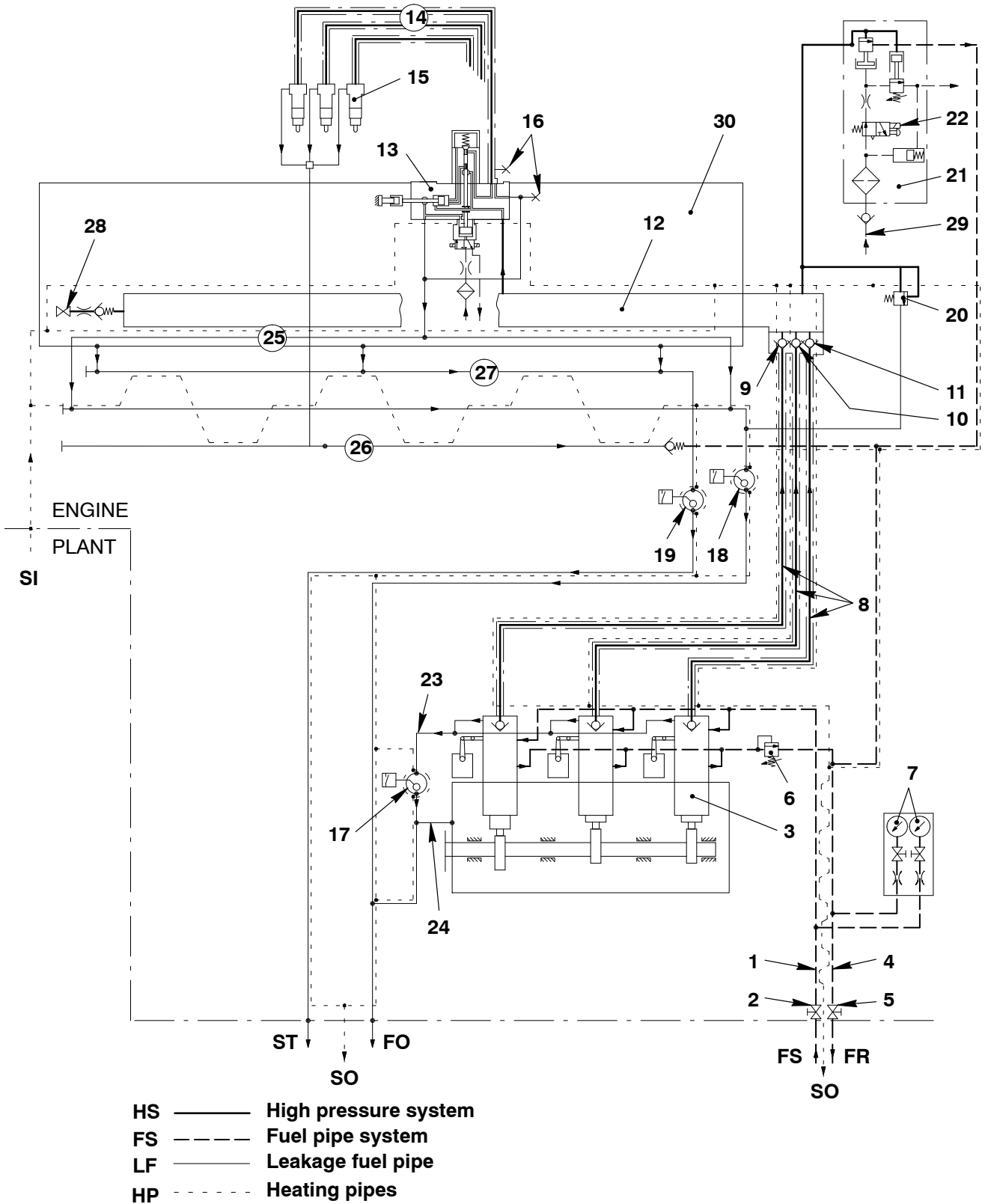

Fuel System

**Key to Illustrations: 'A' Fuel oil system on engine
'B' Pressure retaining valve**

- | | |
|-----------------------------------------------------------------|-------------------------------------------------------|
| 1 Fuel inlet pipe 3.24 | 24 Leakage fuel from fuel pumps |
| 2 Shut-off valve | 25 Leakage fuel (collecting) pipe 3.46 |
| 3 Fuel pump 3.14 | 26 Leakage fuel collecting pipe from injection valves |
| 4 Fuel outlet pipe | 27 Leakage drain from rail unit |
| 5 Shut-off valve | 28 Plug 3.39 |
| 6 Pressure retaining valve 3.53 | 29 Connection from bearing oil system |
| 7 Pressure gages | 30 Rail unit (casing) |
| 8 HP fuel pipe 3.29 | 31 Spindle |
| 9 Non-return valve 3.81-1 | 32 Locknut |
| 10 Non-return valve 3.81-2 | 33 Locknut |
| 11 Non-return valve 3.81-3 | |
| 12 Fuel rail 3.05 | |
| 13 Injection control unit 3.02 | |
| 14 HP pipe 3.47 (to injection valve) | |
| 15 Injection valve 3.01 | FP Fuel pipe system |
| 16 Leakage inspection point 3.17 | FR Fuel return |
| 17 Level switch LS3426A | FS Fuel supply |
| 18 Level switch LS3446A | SO Steam outlet |
| 19 Level switch LS3444A | SI Steam inlet |
| 20 Fuel overpressure safety valve 3.52 | HS High pressure system |
| 21 Fuel pressure control valve 3.06 | HP Heating pipes |
| 22 Fuel shut-down pilot valve 3.08 | FO to fuel overflow tank |
| 23 Leakage fuel collecting pipe of HP fuel pipes and fuel pumps | LF Leakage fuel pipe |
| | ST to sludge tank |

B

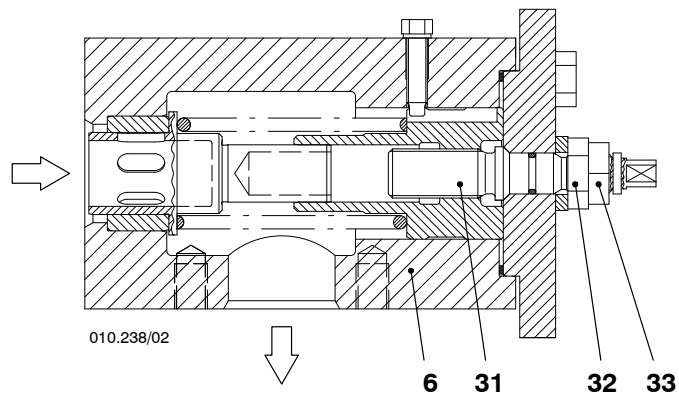

Fuel System

4. Fuel leakage system

4.1 Leakages at inspection points

The fuel leakage system has some leakage inspection points to help you find the location of leakages.



Risk of injury! Always use gloves and safety goggles when you do work on hot components. When drain screws and nuts with conical plugs are opened or when screwed pipe couplings are loosened, fuel can come out as a spray.

The level switches (LS) 17, 18 and 19 (see Fig. 'A') monitor all important leakages in the fuel oil system.

If there is too much leakage, the related alarm is activated.

Level switch	Monitored components
LS3444A	Leakages (fuel and servo oil) from the rail unit
LS3446A	HP pipes 14, injection control units 13 (fuel quantity pistons), fuel overpressure safety valve 20
LS3426A	HP fuel pipes 8, fuel pumps 3

If the level switch 17 (LS3426A) or 18 (LS3446A) activates an alarm, do the procedure that follows:

- ⇒ Loosen the related drain screws 2 (see Fig. 'C').
- ⇒ Loosen the nut with conical plug 3 (see Fig. 'D').
- ⇒ Loosen the screwed pipe coupling of the leakage fuel pipe 35 (see Fig. 'E').

This will help you find the leakage. You can then do the related procedures.

4.2 Leakages at HP fuel pipes

- The level switch 17 (LS3426A) (Fig. 'A') activates an alarm.

4.2.1 Procedure

- ⇒ Carefully loosen the pipe union of the leakage fuel pipe 35 a maximum of two turns (see Fig. 'E'). Do a check to see if fuel flows out or not.



A defective HP fuel pipe can only be replaced after the engine has stopped. If the HP fuel pipe cannot be replaced immediately, the related fuel pump must be cut out (see Cutting Out and Cutting In of the Fuel Pump [5556-2](#)).

- ⇒ Replace the defective fuel HP fuel pipe (see the Maintenance Manual [8752-1](#)).



Remark: If the engine must continue to operate, use the tool 94555 to cut out the related fuel pump at the zero position to stop the fuel supply (see Faults in High Pressure Fuel System [0515-1](#)).

When a fuel pump is cut out, the engine can only operate at decreased load (see [5556-2](#) Cutting Out and Cutting In of the Fuel Pump and [5801-1](#) Regulating Linkage).

Fuel System

4.3 Leakage at HP pipes 3.47

- The level switch 18 (LS3446A, Fig. 'A') activates an alarm.

4.3.1 Procedure:

- ⇒ Carefully loosen the drain screw 2 on the flange 4 of the injection pipe 1 approximately two turns. Do a check to see if fuel flows out or not (see Fig. 'C').

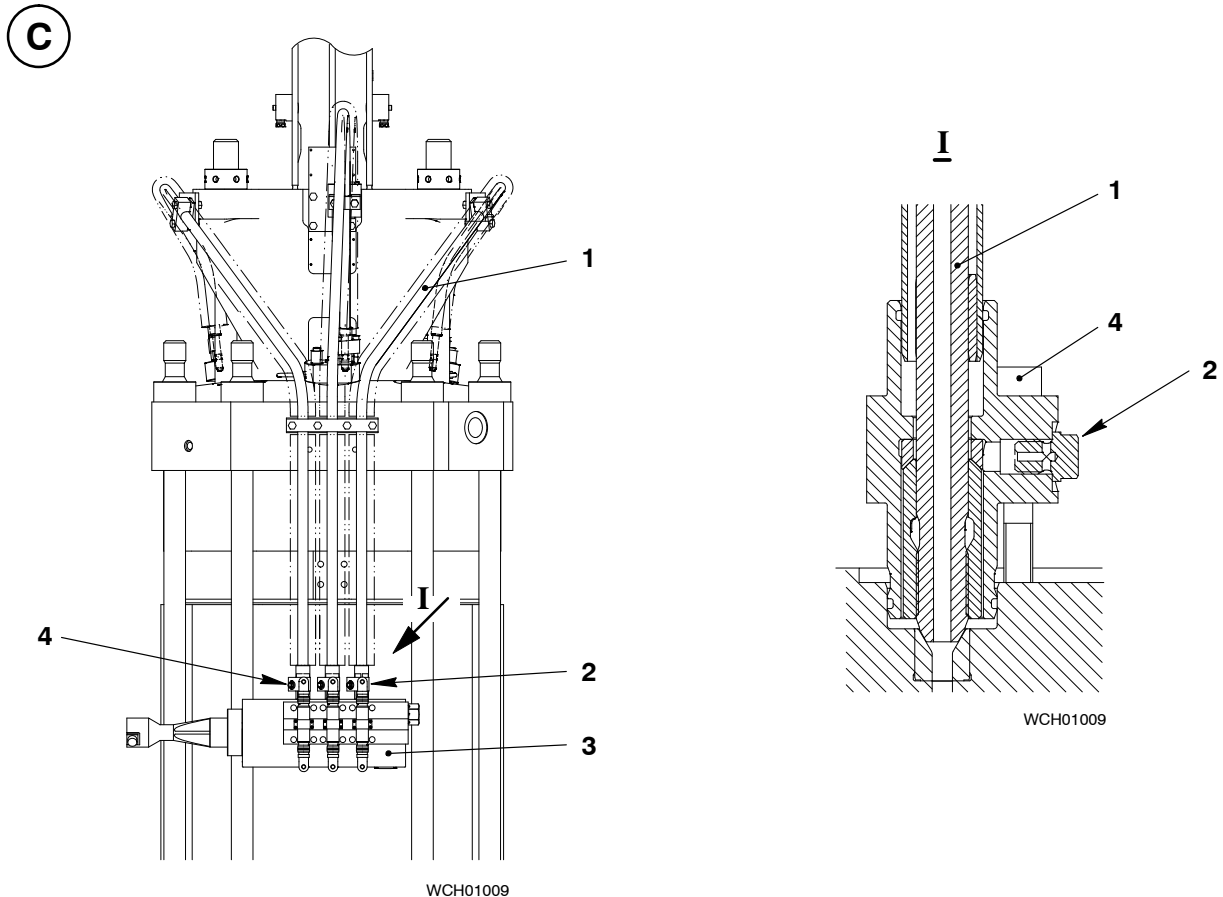

Key to Illustrations: 'C' Leakage inspection point of injection pipes

- | | |
|----------------|-------------------------------|
| 1 HP pipe 3.47 | 3 Injection control unit 3.02 |
| 2 Drain screw | 4 Flange |



Remark: On the related cylinder, there will be an exhaust temperature difference.

- ⇒ Replace the defective injection pipe (see 0510-1 paragraph 2.2 and the Maintenance Manual 8733-1).



You can only replace a defective HP pipe at engine standstill. If the injection pipe cannot be replaced immediately, the injection of the related cylinder must be cut out (see Operation with Injection Cut Out 0510-1).



Remark: When the injection is cut out (Inj. CUT OFF), the engine can only be operated at decreased load.

Fuel System

4.4 Leakage at injection control units 3.02

- The level switch 18 (LS3446A, Fig. 'A') activates an alarm.
- No leakage was found during a check of the injection pipes 14.

4.4.1 Procedure

⇒ Carefully loosen the nut with conical plug 3 on the return pipe 4 a maximum of two turns. Do a check to see if fuel flows out or not (see Fig. 'D').



Risk of injury! Never remove the nut with conical plug 3 during operation. Hot fuel can come out as a spray.



A defective injection control unit can only be replaced at engine standstill. If the injection control unit cannot be replaced immediately, the injection of the related cylinder must be cut out (see Operation with Injection Cut Out 0510-1).

⇒ Replace the defective injection control unit (see 0510-1 paragraph 2.1 and Maintenance Manual 5564-1).

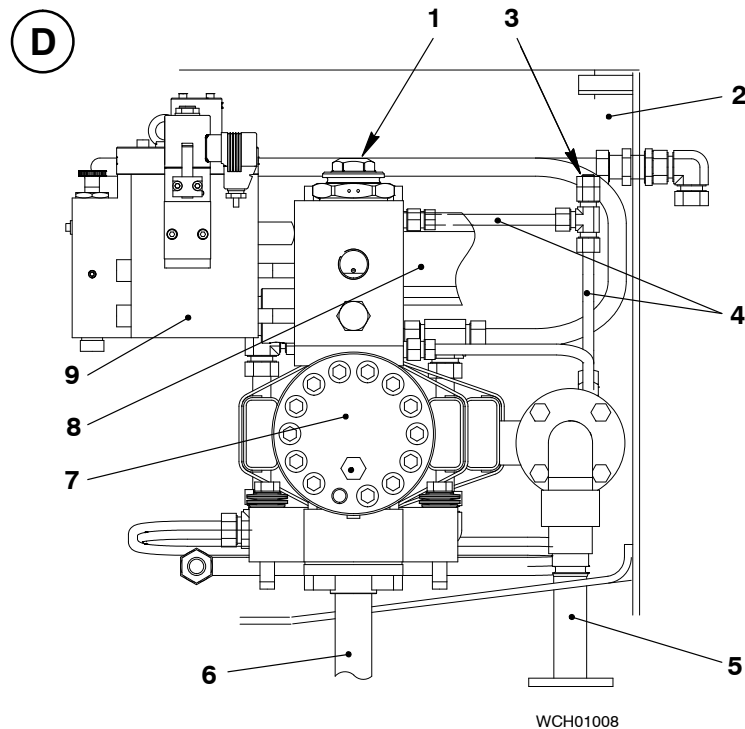

Key to Illustrations: 'D' Leakage inspection point of injection control units

- | | |
|---------------------------------------|------------------------------------|
| 1 Fuel overpressure safety valve 3.52 | 6 High pressure fuel pipe 3.29 |
| 2 Rail unit | 7 Fuel rail 3.05 |
| 3 Nut with conical plug | 8 Injection control unit 3.02 |
| 4 Return pipe | 9 Fuel pressure control valve 3.06 |
| 5 Fuel leakage pipe 3.46 | |

Fuel System

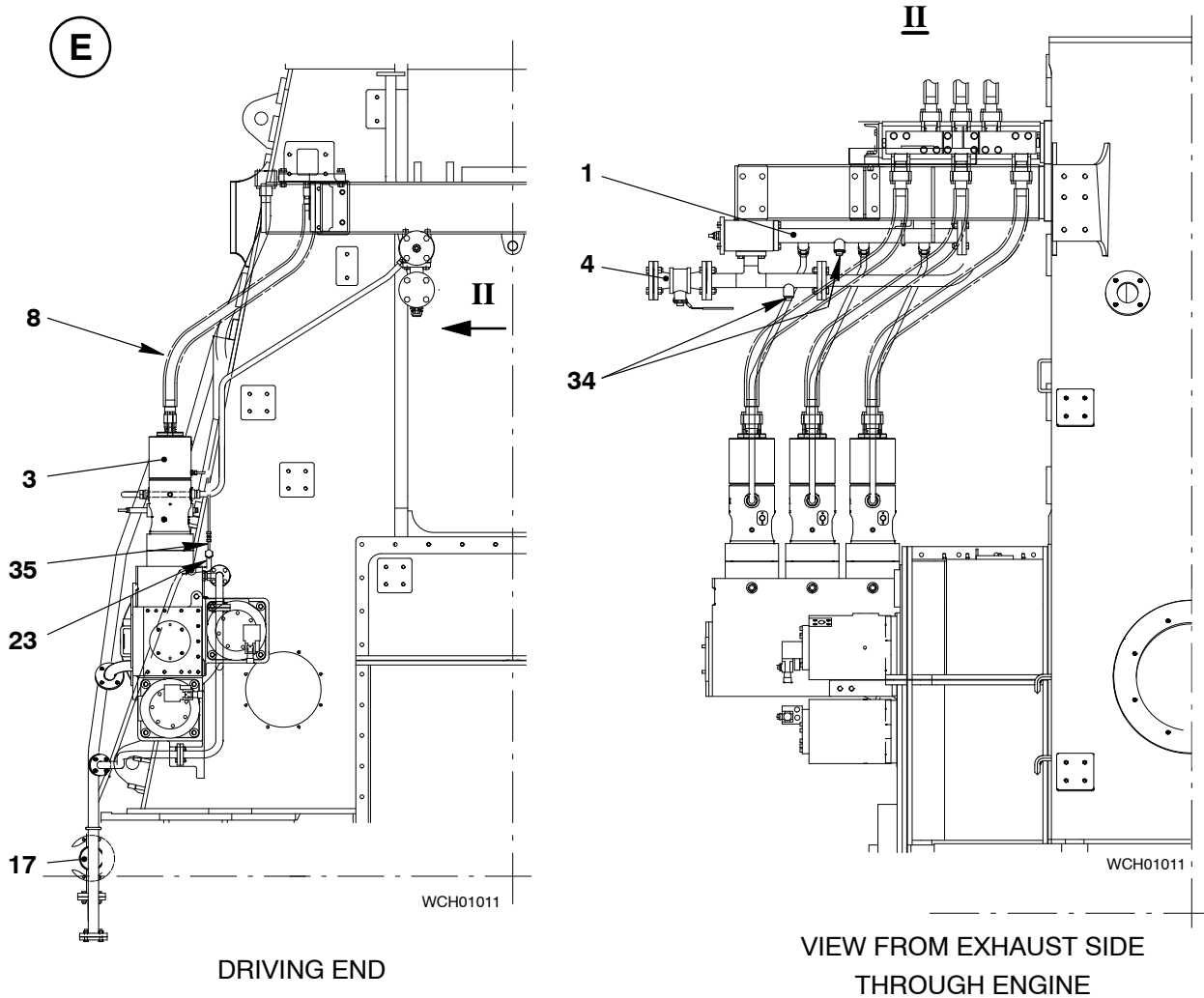

Key to Illustrations: 'E' Leakage inspection point of high pressure fuel pipes

- | | |
|------------------------|---------------------------------------------------|
| 1 Fuel inlet pipe 3.24 | 17 Level switch LS3426A |
| 3 Fuel pump 3.14 | 23 Leakage fuel collection pipe |
| 4 Fuel outlet pipe | 34 Screw plug |
| 8 HP fuel pipe 3.29 | 35 Leakage fuel pipe (HP fuel pipe and fuel pump) |

Intentionally blank

Exhaust Waste Gate (Low-load Tuning)

1. General

The Low-load Tuning (LLT) gives the lowest possible Brake Specific Fuel Consumption (BSFC) in the range of 40% to 70% engine load (see Fig. 'A' for the schematic diagram of the LLT function).

With LLT, engines can operate continuously at all loads in the range of 30% to 100%.

The LLT uses a specially designed turbocharger system and engine parameters. These parameters are related to fuel injection and exhaust valve control and get the best decreased part-load BSFC in LLT.

Engines with LLT have an exhaust gas waste gate installed (i.e. a pneumatically operated valve on the exhaust gas manifold upstream of the turbocharger turbine).

Exhaust gas blown through the waste gate flows to the exhaust uptake.

A turbocharger is used to get LLT for part-load operation. The combustion pressure is increased at less than 75% load through an increased scavenge air pressure (waste gate closed). The waste gate opens at engine loads of more than 85% to prevent damage to the turbocharger and the engine from overload.

The higher scavenge air pressure at part-load causes a decrease in the thermal load and thus, better combustion for the full part-load range.

The engine parameters that control the fuel injection and exhaust valve operation are selected to make sure that the applicable NO_x limit is obeyed.

The specified parameters make sure that the waste gate opens and closes smoothly through the full range. However, higher scavenge air pressure increases NO_x emissions. Thus, to get the correct value for the test cycle, it is necessary to adjust the parameters for the scavenger air pressure increase.

Schematic functional principle of Low-Load Tuning:

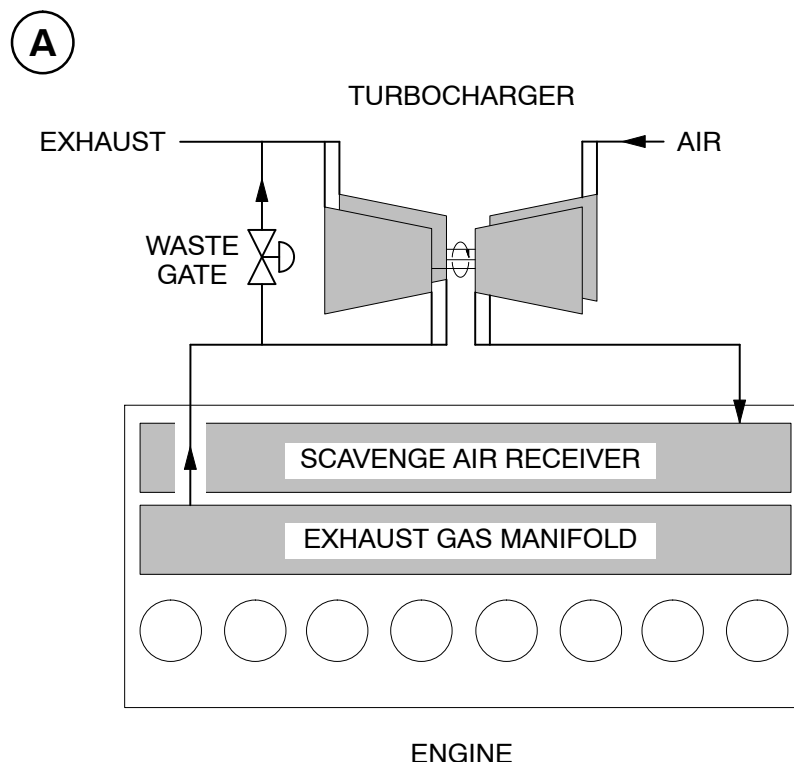

Exhaust Waste Gate (Low-load Tuning)

2. Function

When the load is less than 85% (in accordance with ISO conditions), the force of the spring in the actuator 2 (see Fig. 'B') keeps the butterfly valve 1 in the closed position.

Open:

When the engine load is more than 85%, the scavenge air pressure increases to more than the set limit. The WECS-9520 activates the 3/2-way solenoid valve 4, air spring air is released through the control air pipe 12 to the actuator and the butterfly valve 1 opens.

Close:

When the engine load decreases to less than 85% and the scavenge air pressure decreases to less than the set limit, the WECS-9520 deactivates the solenoid valve. This stops the air spring air supply. The pressure in the system is released and the spring in the actuator closes the butterfly valve.

If a part becomes defective, alarm messages are activated in the WECS-9520 and shown in the alarm and monitoring system (see [0820-1](#) Exhaust waste gate).

3. Function check

A function check is necessary when the engine operates for long periods at low engine load with the exhaust waste gate closed. Do the function check that follows one time each week.



Remark: You can do this function check:

- When the engine is stopped, or
- When the engine operates at less than 70% load.

You can do procedure one or procedure two:

Procedure one:

- ⇒ Turn the screw 6 on the solenoid valve 4 inwards until the butterfly valve 1 opens.
- ⇒ Turn the screw 6 back to its initial position.

Procedure two:

- ⇒ On the USER or ExhWgt page of the flexView, set the manual command to OPEN.

The butterfly valve opens.



Remark: After 20 seconds the butterfly valve will close automatically.

Exhaust Waste Gate (Low-load Tuning)

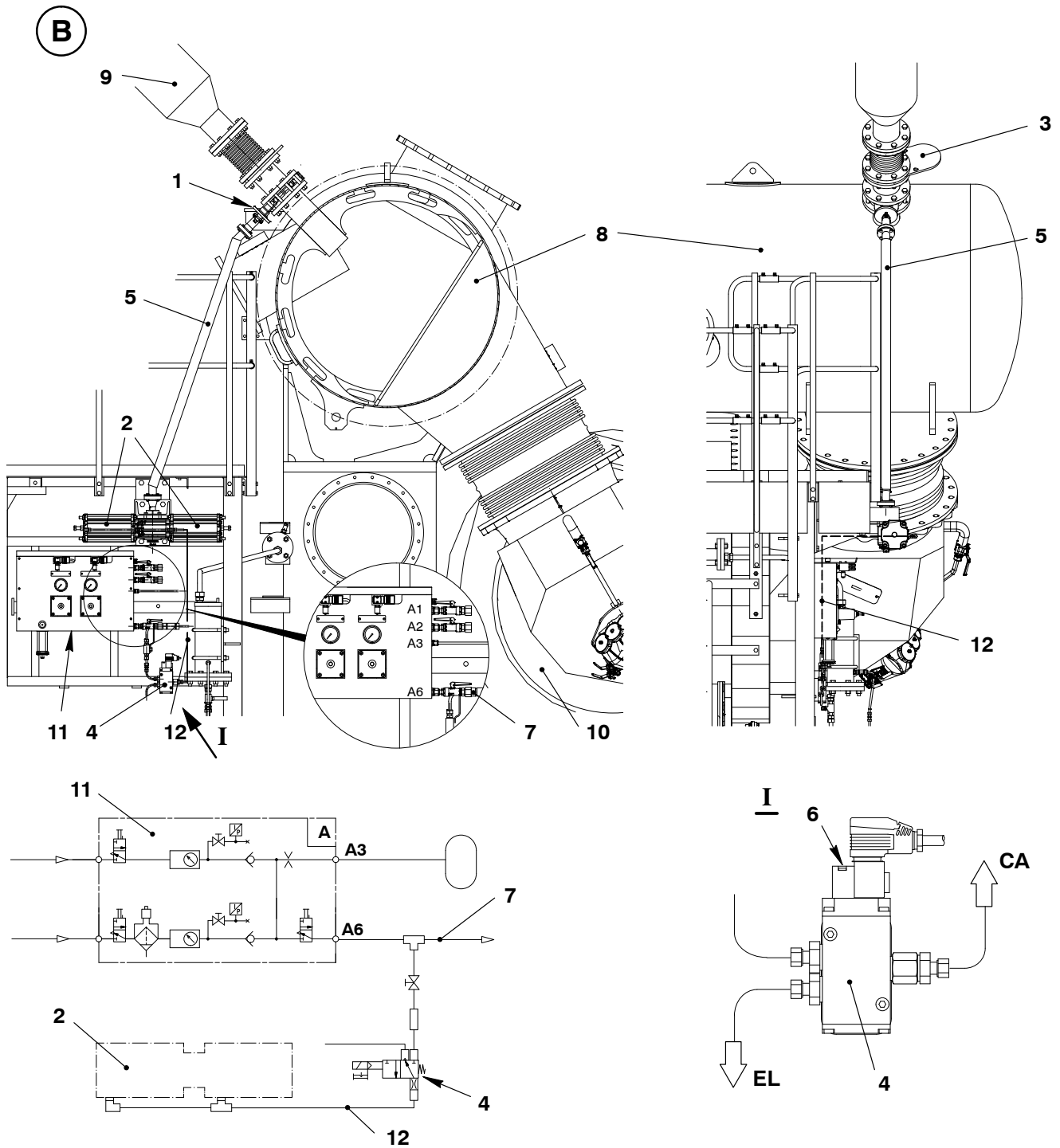

Key to Illustrations:

- | | |
|-----------------------------------|-------------------------------------|
| 1 2/2-way valve (butterfly valve) | 9 Exhaust bypass pipe |
| 2 Actuator | 10 Turbocharger |
| 3 Orifice | 11 Control air supply unit A |
| 4 3/2 way solenoid valve CV7076C | 12 Control air pipe |
| 5 Cardan rod | |
| 6 Screw | |
| 7 Air spring air pipe | |
| 8 Exhaust gas manifold | CA to control actuator |
| | EL Vent |

Intentionally blank

Drainage System and Wash-water Piping System

1. General

You must do checks at regular intervals to make sure that all drain pipes are not blocked. The checks on the drain pipes 3, 10 and 25 from the turbocharger, piston underside and piston rod glands are important (see Fig. 'A').

The ambient temperature and humidity can cause condensate to flow out upstream and downstream of the cooler at the water drain 12. Very high ambient conditions can make up to 0.16 kg/kWh of condensate.

2. Condensate drain

The charging module has four condensate drains. These drains must operate correctly as follows:

- ⇒ Make sure that all valves in the condensate drain pipe are fully open.
- ⇒ Make sure that the 3-way ball cock 22 is in the position USUAL OPERATION (see Fig. 'B').



Remark: During engine operation, the butterfly valves 18 must always be set to the closed position.

The condensate will flow off through the orifice plate, but:

- Dirt particles (rust) can collect in the butterfly valves 18
- ⇒ Open the butterfly valves 18 at regular intervals to remove dirt particles.
- ⇒ At regular intervals, look at the sight glasses 20 to make sure that water flows.

See also [0240-1](#) Checks and precautions, paragraph 2.

If one, or the two level switches 7 activates an alarm (condensate level too high), you must find the cause immediately and correct the defect. The possible causes of the alarm are:

- The 3-way ball cock 22 is in position CLOSED (see Fig. 'B').
- The scavenge air cooler is defective (see [0550-1](#)).
- There is too much contamination in the butterfly valves 18 (the orifice plate is blocked).
- You must clean the butterfly valves 18 and orifice plates as soon as possible.



Attention! You must clean the butterfly valves 18 and orifice plates only at engine standstill.

Blocked drains let too much condensate collect in the scavenge air receiver. The water / water vapor has an unwanted effect on piston operation and increases wear on the piston rings and cylinder liners.

Drainage System and Wash-water Piping System

A

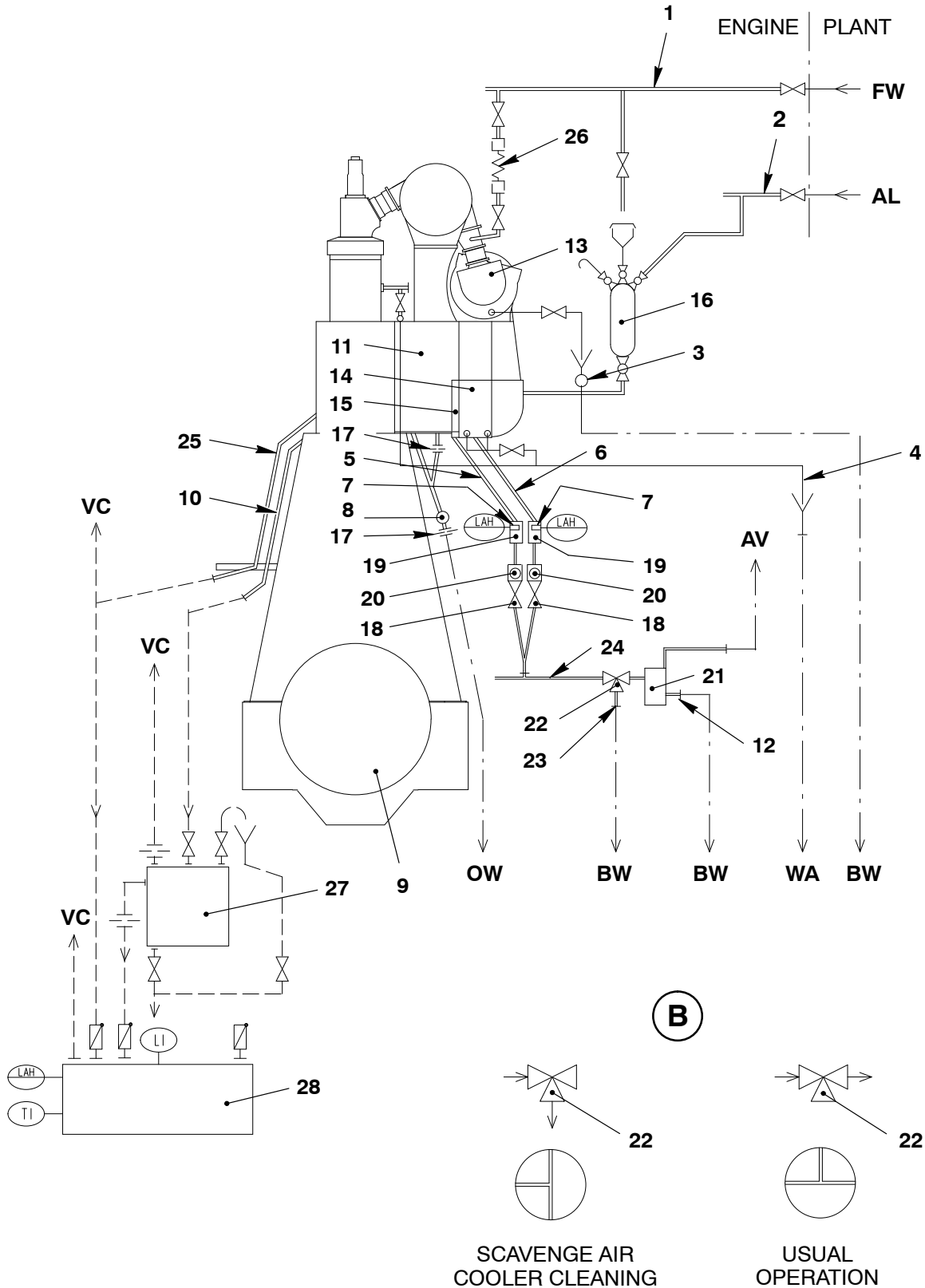

B

Drainage System and Wash-water Piping System

Key to Illustrations: 'A' Diagram

'B' Positions of 3-way ball cock

- | | |
|----------------------------------------------------------------|--------------------------------------------------------------------|
| 1 Wash-water supply pipe | 21 Venting unit |
| 2 Compressed air supply pipe | 22 3-way ball cock |
| 3 Wash-water drain from turbocharger
(for TPL type) | 23 Cleaning agent and wash-water
drain from scavenge air cooler |
| 4 Cylinder cooling water and
scavenge air cooler drain | 24 Condensate and dirty water
collection pipe |
| 5 Condensate pipe
from water separator | 25 Leakage oil collection pipe
from piston rod gland |
| 6 Condensate and wash-water pipe
from scavenge air cooler | 26 Connection hose |
| 7 Level switch for condensate drain | 27 Sludge oil trap (with heater coil) |
| 8 Water drain from receiver (oleiferous) | 28 Sludge oil tank |
| 9 Engine | |
| 10 Dirty oil drain from piston underside | |
| 11 Scavenge air receiver | |
| 12 Water drain from water separator
and scavenge air cooler | AL Air line from board system |
| 13 Exhaust gas turbocharger | AV Air vent |
| 14 Scavenge air cooler | VC to vent collector |
| 15 Water separator | FW from fresh-water hydrophore system |
| 16 Scavenge air cooler wash plant | LAH Level alarm high |
| 17 Orifice plate | LI Level indicator |
| 18 Butterfly valves
with orifice plate | OW Drain to oil / water drain tank |
| 19 Float / solenoid switch units | TI Temperature indicator |
| 20 Sight glasses | WD to water drain tank |
| | BW Drain to bilge water tank |

Intentionally blank

Engine Monitoring

Group 9

Instrument Panel	9215-1/A1
Crank Angle Sensor Unit	9223-1/A1
Pressure Switches and Pressure Transmitters	9258-1/A1
Intelligent Combustion Control	9308-1/A1
Oil Mist Detector	9314-1/A1
Location of flex Electronic Components	9362-1/A2

Intentionally blank

Instrument Panel

1. General

The instrument panel 1 (see Fig. 'A') is installed next to the control box. The instrument panel contains important pressure gauges necessary to monitor the pressures. Pressure indications for fuel and servo oil are given in the local control panel (see 4618-1).

Fig. 'B' shows the schematic diagram of the instrument panel H with the same indications also shown in the Control Diagram 4003-2. Data about the related pressure switches and pressure transmitters are given in 9258-1.

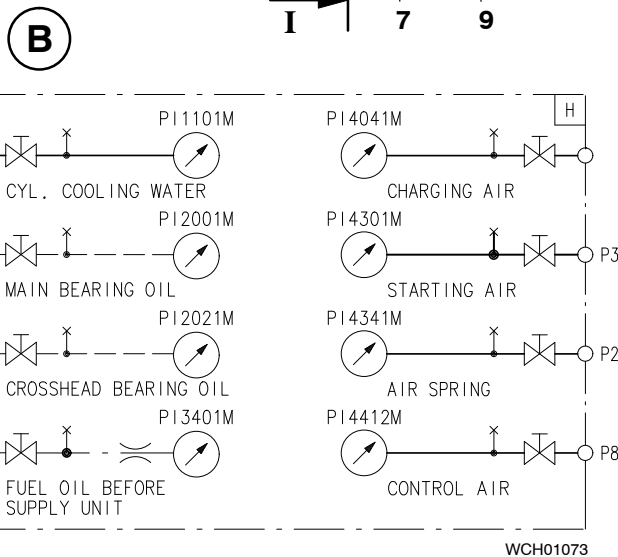
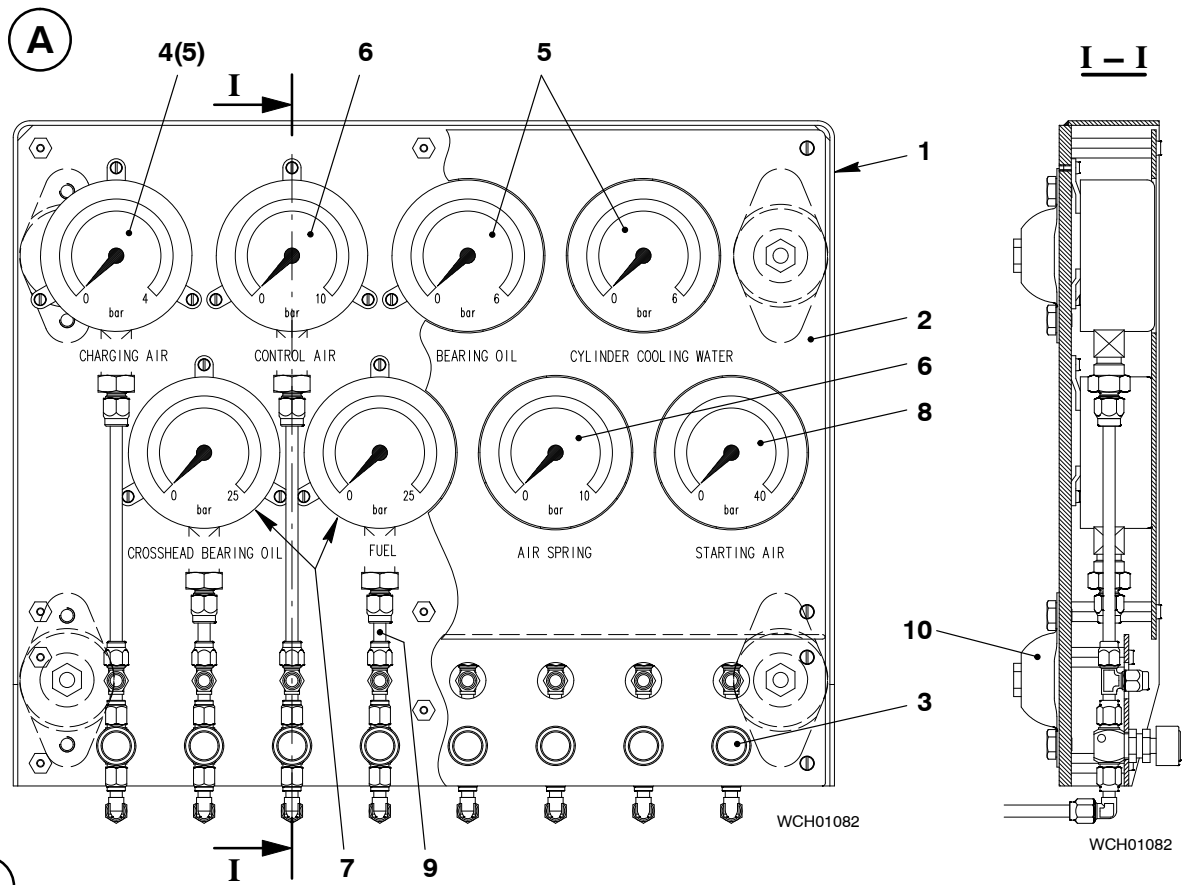

Key to Illustrations Fig. 'A' and 'B':

- 1 Instrument panel
- 2 Cover plate
- 3 Precision control valve
- 4 Pressure gage 4 bar
- 5 Pressure gage 6 bar
- 6 Pressure gage 10 bar
- 7 Pressure gage 25 bar
- 8 Pressure gage 40 bar
- 9 Throttle piece
- 10 Anti-vibration mounting

Intentionally blank

Crank Angle Sensor Unit

1. General

The crank angle sensor unit is installed at the free end. The connecting unit 2 is attached to the crankshaft 10 over the drive shaft 1. The connecting unit absorbs all unwanted radial and axial movements of the crankshaft.

The toothed belt 8 operates the two crank angle sensors 7, which give indications of the crank angle positions. A proximity sensor monitors the position of the TDC signal (see 4628-1 Pick-up for Speed Measurement).

All differences are monitored and displayed with an alarm.

You must lubricate the ball bearing 9 at regular intervals. For data about the lubrication, see the Maintenance Manual 0380-1 and 9223-1.

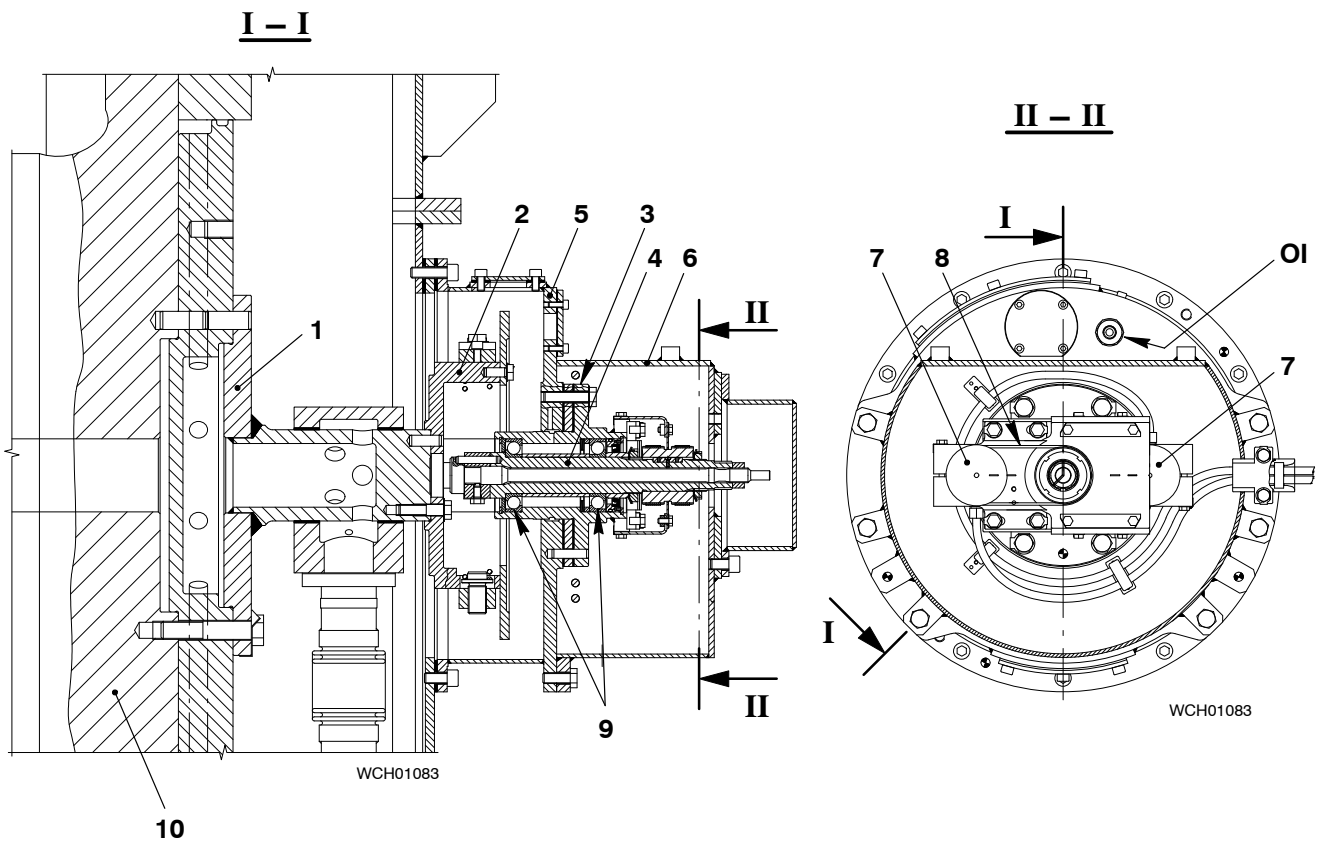

Key to Illustrations:

- | | |
|-----------------------|-----------------------------------------|
| 1 Drive shaft | 7 Crank angle sensor (GT5126C, GT5127C) |
| 2 Connecting unit | 8 Toothed belt |
| 3 Shaft encoder drive | 9 Ball bearing |
| 4 Shaft | 10 Crank shaft |
| 5 Housing | |
| 6 Protection hood | OI Oil inlet |

Intentionally blank

Pressure Switches and Pressure Transmitters

1. General

All of the pressure switches and transmitters are installed on the same plate at the free end. The pressure switches and transmitters monitor the pressure systems. If there is a decrease in pressure or there is no pressure, the control signals have an effect on the commands that follow:

- Alarm (ALM)
- Slow down (SLD)
- Shut down (SHD)

For more data, see 0250-2 Alarms and Safeguards at Continuous Service Power.

Fig. 'A' shows a schematic diagram of the pressure switches and pressure transmitters I as shown in the control diagram 4003-2. Fig. 'B' shows the locations of the pressure transmitters and pressure switches.

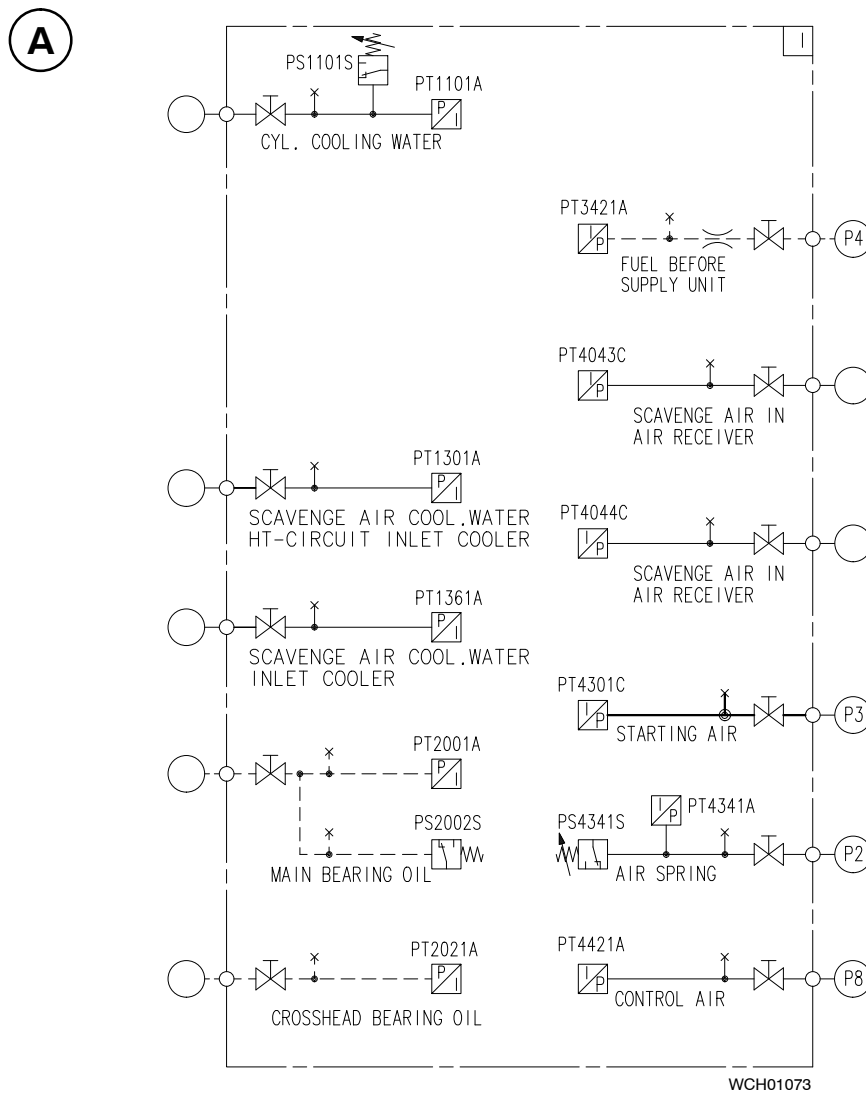

Key to Illustrations: 'A' Schematic diagram

Pressure Switches and Pressure Transmitters

B

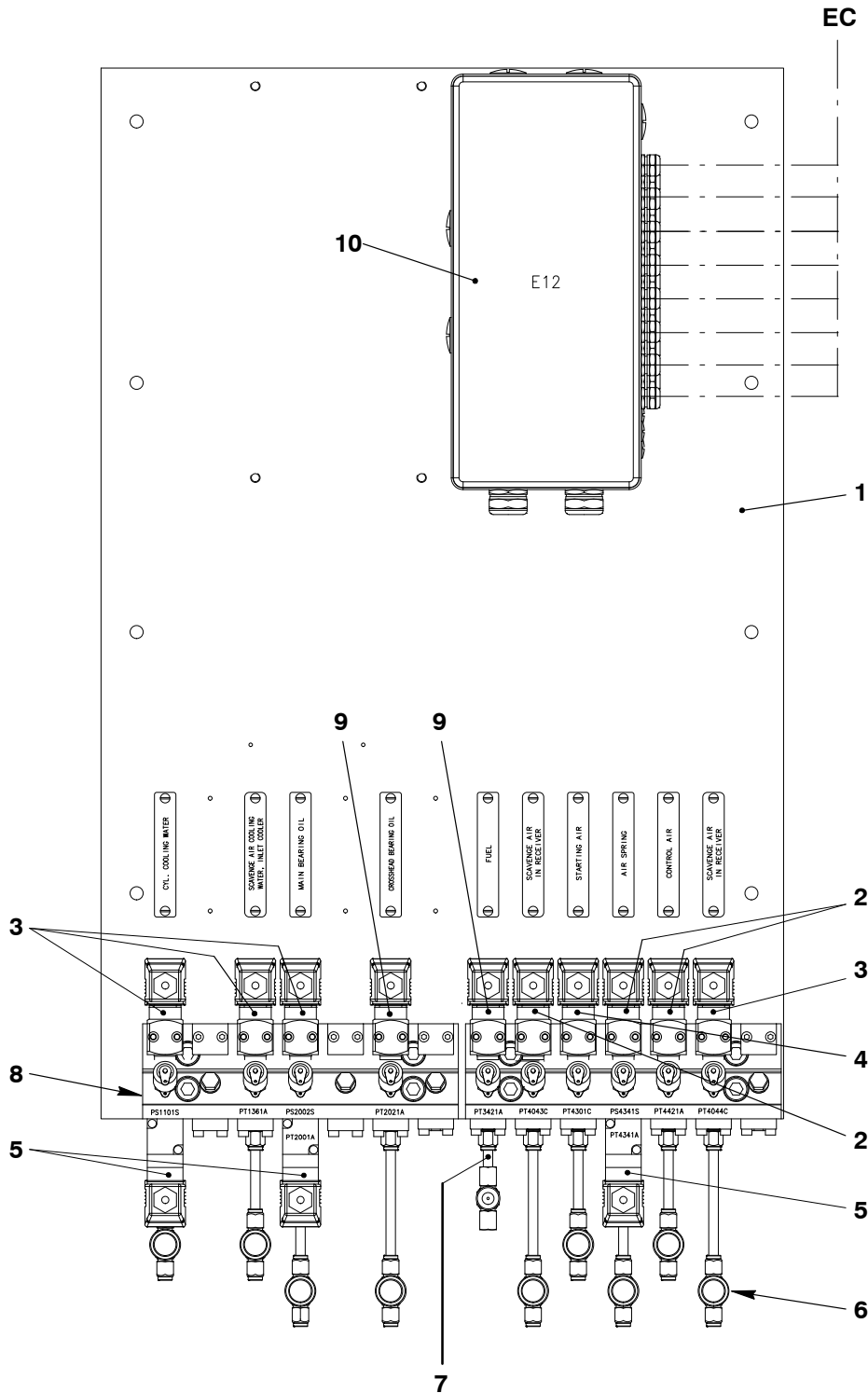

Key to Illustrations: 'B' Pressure switches and pressure transmitters

- | | |
|-------------------------------|-------------------------------|
| 1 Plate | 7 Throttle piece |
| 2 Pressure transmitter 6 bar | 8 Connecting piece |
| 3 Pressure transmitter 10 bar | 9 Pressure transmitter 16 bar |
| 4 Pressure transmitter 40 bar | 10 Terminal box |
| 5 Pressure switch 6 bar | |
| 6 Regulating valve | EC Cable |

Intelligent Combustion Control

Overview

1	Introduction	1/9
2	Safety	1/9
2.1	User qualification	1/9
2.2	Residual dangers	2/9
2.3	Installation and maintenance	2/9
3	Description	2/9
3.1	Pressure transducers	2/9
3.2	In-cylinder pressure evaluation	3/9
3.3	ICC - Installation and control	3/9
4	Operation	5/9
4.1	Operation of ICC	5/9
4.1	ICC-EXV card	5/9
4.2	ICC-INJ card	7/9
4.3	ICC-INDICATION card	9/9

1. Introduction

The Intelligent Combustion Control (ICC) system makes sure that the engine in service is operated in accordance with its original shop test performance. This is done automatically in and independently of the fuel used on board a vessel (e.g. HFO).

At present, the engine control parameters (e.g. start of injection or exhaust valve timing) are optimized manually within their permitted range in relation to the measured peak firing and compression pressures. This manual adjustment procedure is not done regularly, thus further optimization potential can be exploited by permanently working closed-loop control.

Because of this functionality, the engine operation is always at its best.

2. Safety



Remark: The ICC system can only be installed, operated, serviced and repaired by qualified personnel.

2.1 User qualification

Qualified personnel are those who are trained, appointed and instructed by the system's user. The personnel know the related standards, provisions, accident-prevention regulations and plant conditions through their training, experience and instruction. Personnel are entitled to do the necessary work while at the same time recognize and prevent possible hazards.

The DIN VDE 0105 or IEC 364 regulations control the definition of skilled personnel and the ban on the use of unqualified personnel.

Intelligent Combustion Control

2.2 Residual dangers

The ICC system is manufactured in accordance with the generally recognized rules of engineering, industrial safety and accident-prevention regulations. However, during its use it is possible that hazards could occur, which can lead to injuries to personnel or which could cause damage to other property.

The ICC system must be used only in a technically faultless state, in accordance with the operating instructions. Faults that can decrease safety must be corrected immediately.

2.3 Installation and maintenance

Read the local accident-prevention regulations and the related operating and maintenance instructions when you work on the machine or system. It is important that the shutdown procedure for the machine or system is followed as given in the related instruction manual.

3. Description

The ICC system is an optional part of the WECS-9520, which adjusts the peak firing pressure of the engine according to engine design criteria. The injection timing and exhaust valve timing are changed to balance the firing and compression pressure of all cylinders in their permitted range. All modifications to engine control parameters that the ICC activates are in accordance with the vessel's IMO certificate.

During operation, the ICC system puts a limit on the pressure increase of the engine as an included safety function. This decreases wear of engine components, risks of overload and prevents potential incorrect manual adjustments if there is an open-loop control.

3.1 Pressure transducers

The accurate and continuously measured in-cylinder pressure of all units forms the structure of the ICC system.

The pressure transducers (Pressductor® technology, related to a magneto-elastic measuring principle) are used to measure the in-cylinder pressure.

The transducers (see Fig. 'A') are installed on the cylinder cover just below the indicator cocks (one on each cylinder).

A

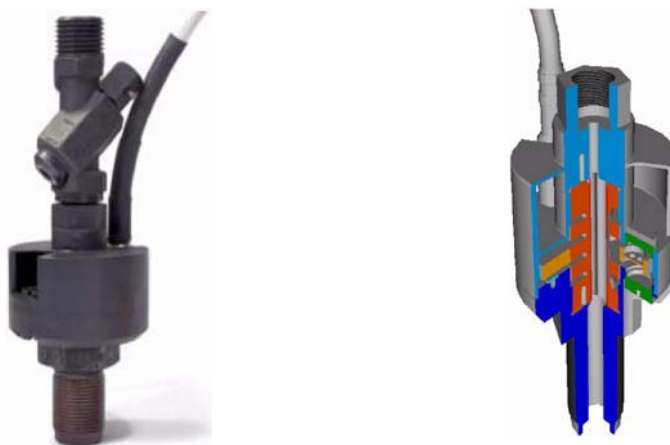

Cylinder pressure transducers

Intelligent Combustion Control

The transducers have a unique blow-through design. Usually before main engine start, the indicator cocks are opened while slowly turning the engine. During that time, all potential combustion residuals (especially from the use of HFO) are blown out.

This cleaning function guarantees accurate measurement data during long-term operation and decreased maintenance work.

3.2 In-cylinder pressure evaluation

The compression pressure cannot be measured directly because of combustion and fuel injection that can occur before TDC.

In the ICC system, the polynomial formula related to the position of the piston is used to calculate the compression pressure of each cycle.

The peak firing pressure is the highest measured pressure value in the crank angle range between the injection start and approximately 20°CA after TDC as shown in Fig. 'B'.

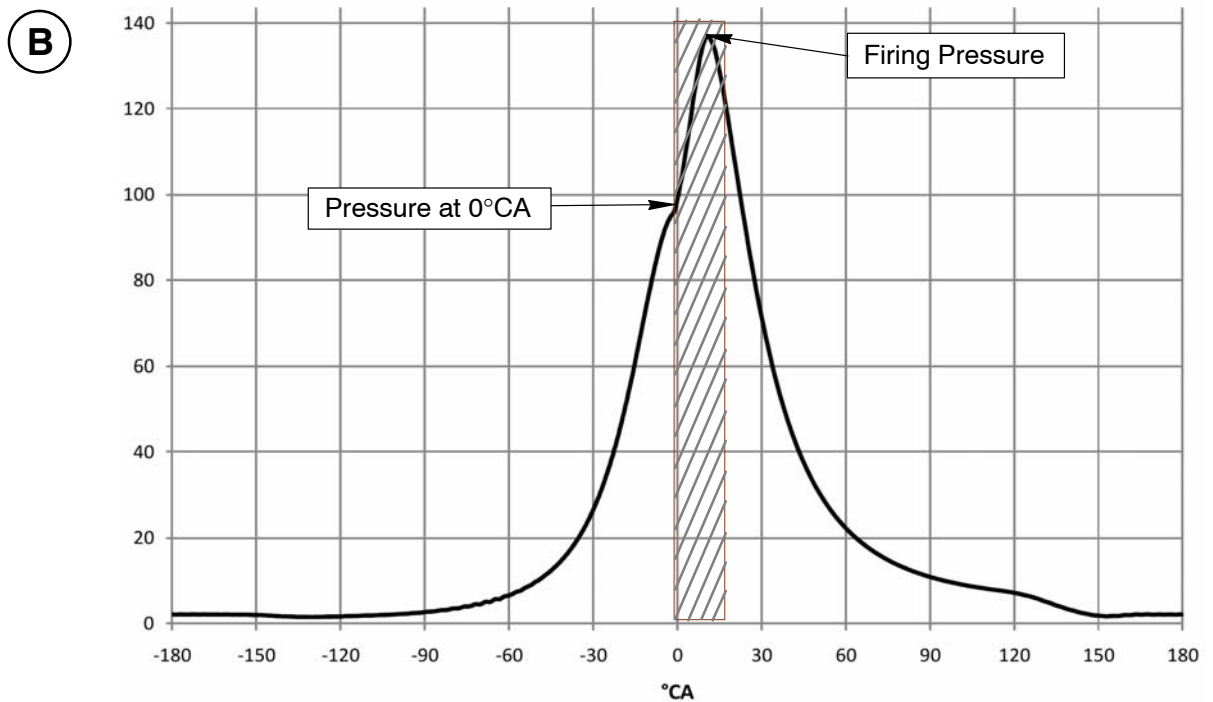

Cylinder pressure trace of a two-stroke engine

The ICC system gives a limit to the pressure increase, e.g. 40 bar (the difference between the firing pressure and compression pressure) to prevent mechanical overload.

3.3 ICC - Installation and control

The necessary firing pressure, data read from the shop test, is converted back (by a reverse ISO correction) to site conditions at each actual operating point of the engine. This makes sure that the engine firing pressure is adjusted in relation to its design criteria and the engine is not overloaded while the full potential is used.

Together with the ICC, temperature and pressure sensors (that are directly connected to the WECS-9520) are installed upstream of the turbocharger (TC) compressor inlet and in the scavenge air receiver. The ICC and these temperature and pressure sensors continuously monitor the real-time ambient conditions and let the engine adapt to daily differences in regional climates.

Intelligent Combustion Control

The cylinder pressure data of each unit is an analogue input signal from the pressure transducer into the WECS-9520 as shown in the ICC installation overview below (see Fig. 'C').

C

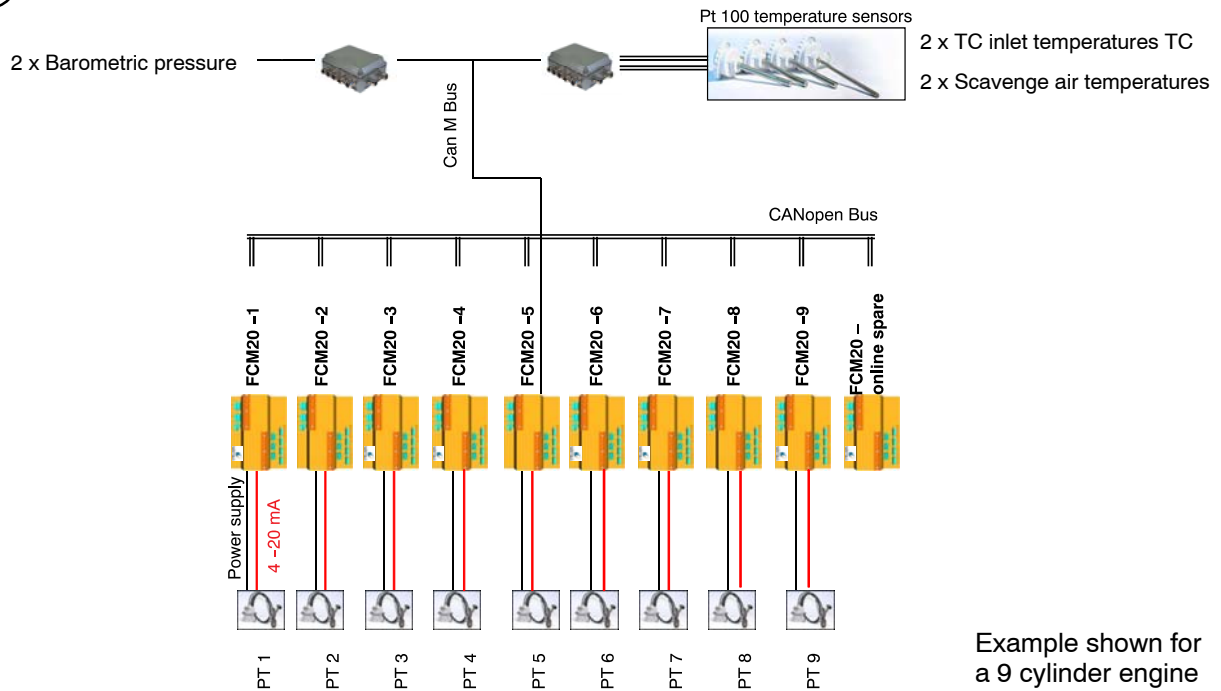

Initially, the signal is filtered in the WECS-9520, then routed to a controller. Adjustments of this measured pressure value to its corrected set-point value at a specified engine load are done accordingly. This real-time site correction and comparison, shown in the pressure control strategy (see Fig. 'D'), is done for each individual engine cycle.

D

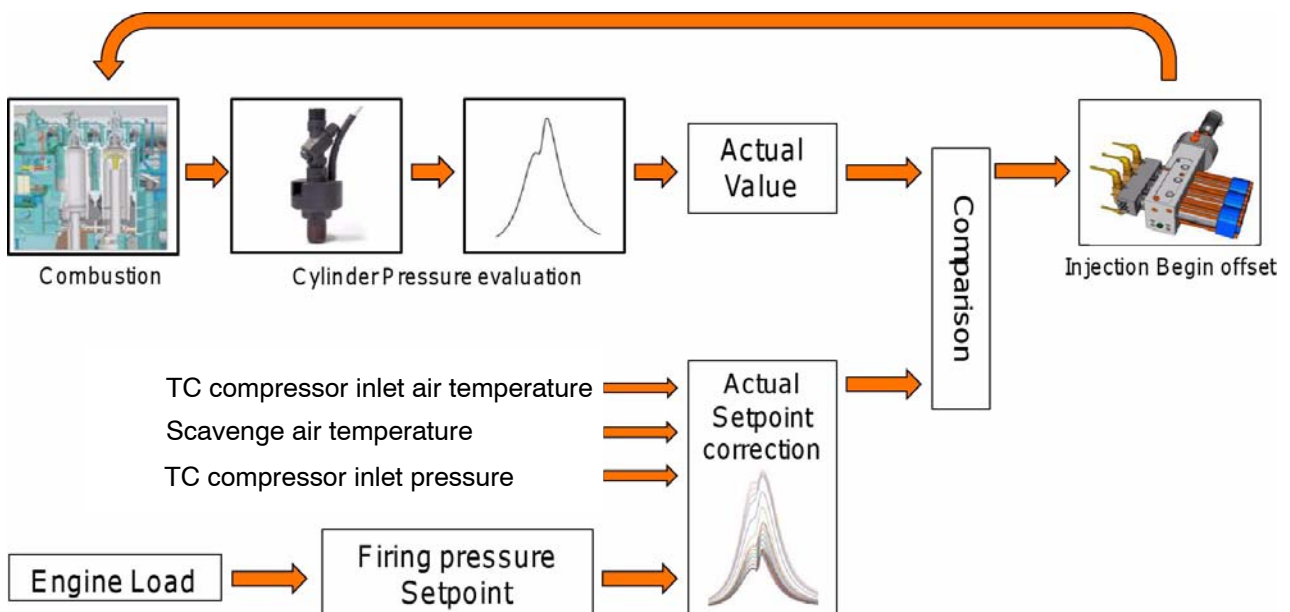

Intelligent Combustion Control

4. Operation

4.1 Operation of ICC

In the WECS-9520 it is possible to set to on or off each individual sub-function of the ICC system. The system adjusts the necessary average value of the firing pressure to its site-corrected set-point value. This balances the firing pressure of all units and balances the compression pressure.

When all sub-functions are set to off, the engine operates in a conventional open-loop control mode.

The in-cylinder pressure balancing and the firing pressure control are enabled to more than the operating range of the auxiliary blowers (the auxiliary blowers are set to off).

The exhaust valve timing and injection timing of each cylinder unit is adjusted to get balanced compression and firing pressures.

Differences of single unit values for exhaust valve operation and injection timing compared to other units are already an indication for hardware issues of specified cylinder units and should be further investigated.

4.2 ICC-EXV card

The flex-view card (see Fig. 'E') shows the measured values of the compression pressure for each cylinder together with the average value of compression pressures for all cylinders. On the right-hand diagram, the exhaust valve closing offset values and the average offset value are shown.

E

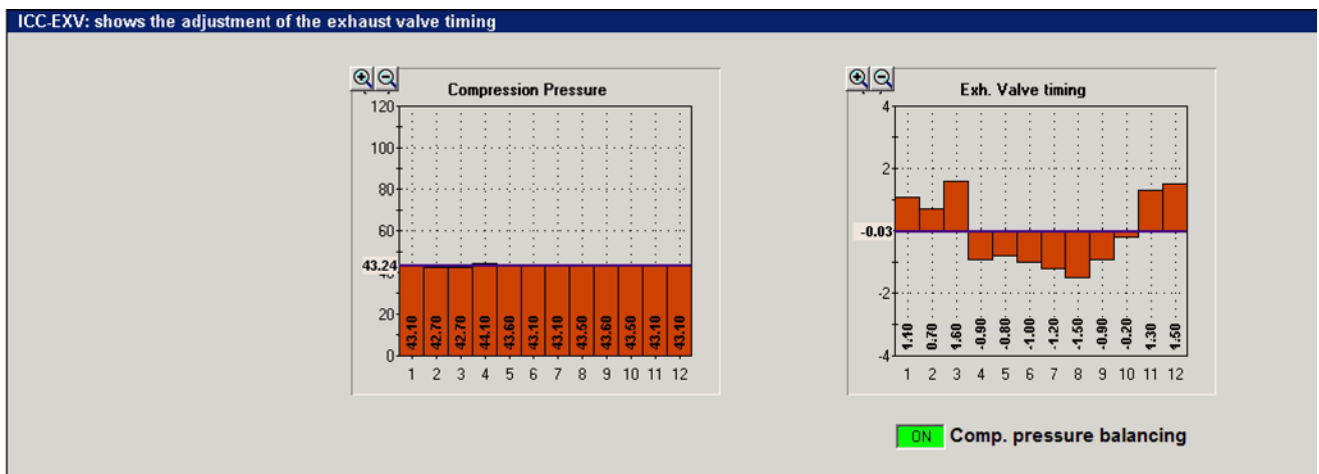

Intelligent Combustion Control

When the compression pressure balancing function is set to ON (see Fig. 'F') the ICC system calculates the offset.

F

ON Comp. pressure balancing

When the compression pressure balancing function is set to OFF (see Fig. 'G'), the offset is the same as on the flexView Adjust card that the operator has adjusted.

G

OFF Comp. pressure balancing

From the ICC-EXV card (Fig. 'E'), the compression pressure balancing function can be set to ON as follows:

⇒ Select [Shift] + [Arrow UP].

⇒ To confirm, select [Shift] + [Enter] (see the workflow in Fig. 'H').

H

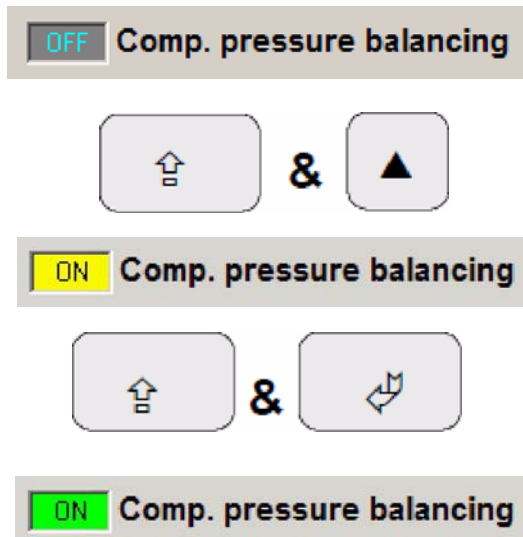

Intelligent Combustion Control

4.3 ICC-INJ card

The flex-view card (see Fig. 'I') shows the measured values of the cylinder firing (combustion) pressure in each cylinder unit. The yellow horizontal line shows the average firing pressure value and the green horizontal line shows the firing pressure set-point. On the right-hand diagram, the injection begin timing offset and the average offset value is shown.

I

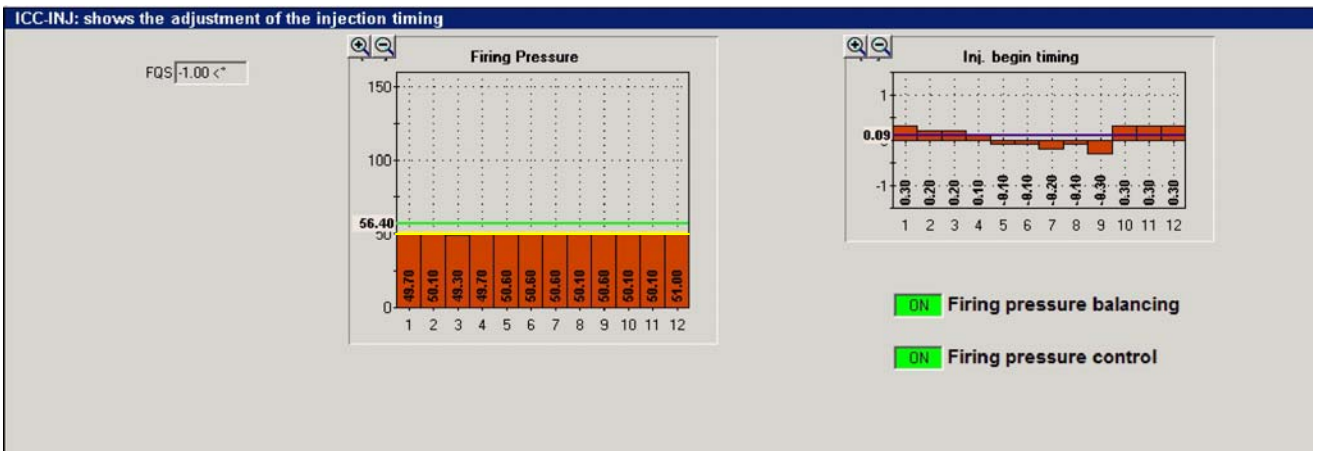

When the firing pressure balancing function is set to ON (see Fig. 'J'), the ICC system calculates the offset.

J



When the firing pressure balancing function is set to OFF (see Fig. 'K'), the offset is the same as shown on the flexView Adjust card that the operator has adjusted.

K



Intelligent Combustion Control

From the ICC-INJ card, the firing pressure balancing function can be set ON as follows:

⇒ Select [Shift] + [Arrow UP]

⇒ To confirm, select [Shift] + [Enter] (see the workflow in Fig. 'L').

(L)

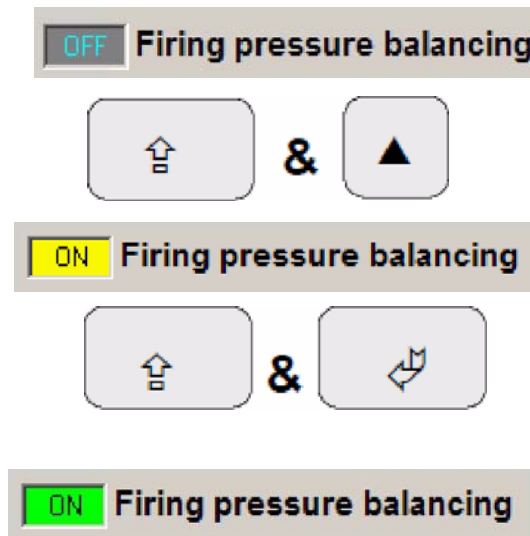

When the firing pressure control function is set to ON (see Fig. 'M'), the ICC system calculates the related Fuel Quality Setting (FQS). The FQS is shown in the top left-hand corner of the ICC-INJ card (Fig. 'I').

(M)



When the firing pressure control function is set to OFF (see Fig. 'N'), the FQS is the same as shown on the flexView USER card that the operator has adjusted.

(N)



Intelligent Combustion Control

From the ICC-INJ card, the firing pressure control function can be set to ON as follows:

- ⇒ Select [Shift] + [Arrow UP]
- ⇒ To confirm, select [Shift] + [Enter] (see the workflow in Fig. 'O').

O



4.4 ICC-INDICATION card

The ICC-indication card (see Fig. 'P') shows the data that follows:

- The compression firing pressures and firing pressures for each cylinder unit
- The firing pressure set-point
- The air pressure and air temperature upstream of the TC compressor
- The scavenge air temperature.

P

Comp. Pressure		Firing Press.	Air Pressure before TC	Air Temperature before TC
average	43.2 bar	average	average/default	average/default
Cyl. 1	43.1 bar	Cyl. 1	Sensor 1	Sensor 1
Cyl. 2	42.7 bar	Cyl. 2	Sensor 2	Sensor 2
Cyl. 3	42.7 bar	Cyl. 3		
Cyl. 4	43.1 bar	Cyl. 4		
Cyl. 5	43.1 bar	Cyl. 5		
Cyl. 6	42.7 bar	Cyl. 6		
Cyl. 7	43.6 bar	Cyl. 7		
Cyl. 8	43.5 bar	Cyl. 8		
Cyl. 9	43.6 bar	Cyl. 9		
Cyl. 10	43.1 bar	Cyl. 10		
Cyl. 11	42.7 bar	Cyl. 11		
Cyl. 12	43.1 bar	Cyl. 12		

Firing Press.		Air Pressure before TC		Air Temperature before TC	
average	51.2 bar	average/default	1022 mbar	average/default	19.5 °C
Cyl. 1	50.1 bar	Sensor 1	1022 mbar	Sensor 1	19.5 °C
Cyl. 2	49.3 bar	Sensor 2	1022 mbar	Sensor 2	19.5 °C
Cyl. 3	50.6 bar				
Cyl. 4	50.6 bar				
Cyl. 5	52.3 bar				
Cyl. 6	50.6 bar				
Cyl. 7	52.8 bar				
Cyl. 8	51.9 bar				
Cyl. 9	51.5 bar				
Cyl. 10	49.7 bar				
Cyl. 11	52.3 bar				
Cyl. 12	51.0 bar				

Scavenge Air Temperature	
average/default	43.5 °C
Sensor 1	43.4 °C
Sensor 2	43.6 °C

Intentionally blank

Oil Mist Detector

1. General

The engine has an oil mist detection system, which includes the sensors 1 and a junction box 4 on the engine (see Fig. 'A').

A control panel is installed in the control room (see Fig. 'B').

The system continuously measures the density of oil mist in the crankcase. If the oil mist intensity is too high, an alarm is activated.

Damage to the bearings is quickly found and explosions in the crankcase are prevented (see also Instructions Concerning the Prevention of Crankcase Explosions 0460-1).

The sensors are installed on the fuel side of the engine:

- For each cylinder of the divided crankcase
- In the drive supply unit
- On the supply unit housing.

2. Function

Each sensor optically monitors the concentration of oil mist. Each sensor has a self-test function to make sure that there are no internal faults.

Data communication is between the junction box and the control panel.

The adjustments can be programmed in the control panel.

The menu-driven software has three user levels:

- User: Read-out of data only.
- Operator: Password-protected level for access to most adjustments and functions.
- Service: Password-protected level for authorized staff of manufacturer and service personnel.



Remark: Instructions that relate to adjustments, commissioning, troubleshooting, and maintenance are given in the related documentation of the manufacturer.

Oil Mist Detector

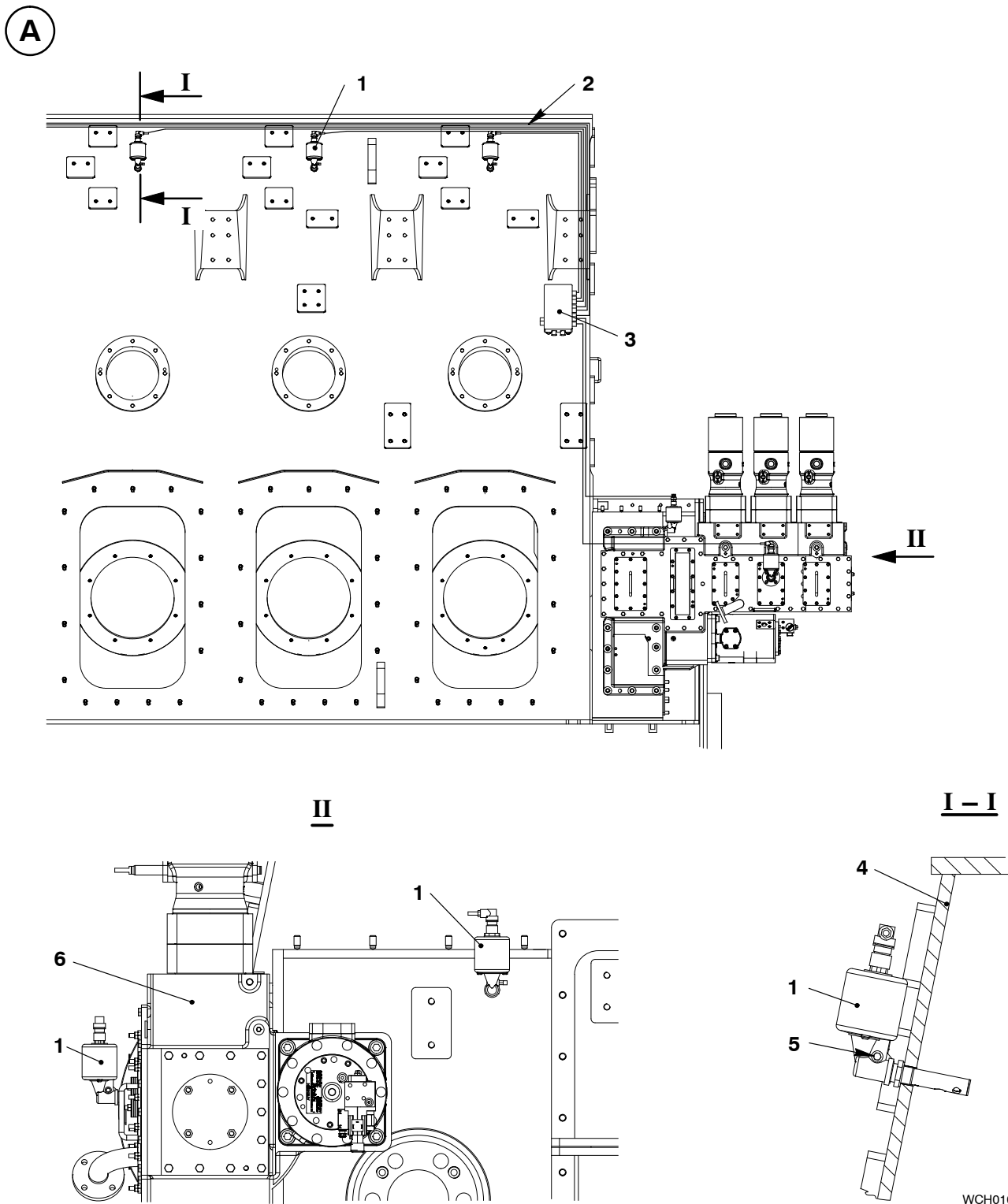

WCH01079

Key to Illustrations: 'A' Location of sensors

- | | |
|----------------|-------------------|
| 1 Sensor | 4 Column |
| 2 Cable guide | 5 Test connection |
| 3 Junction box | 6 Supply unit |

Oil Mist Detector

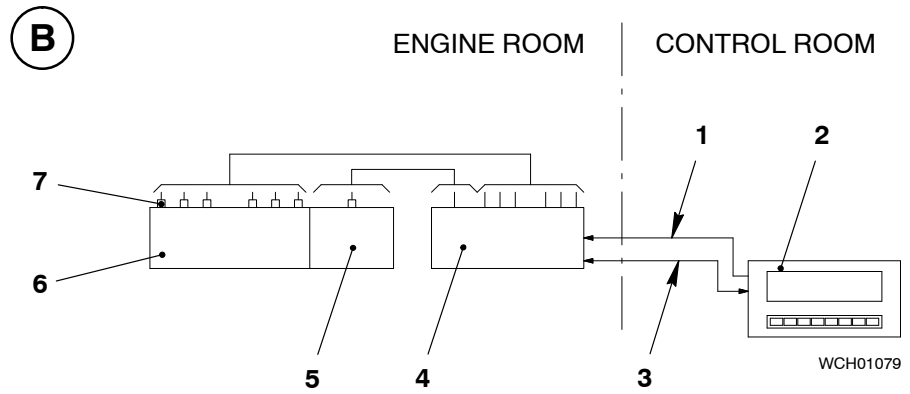

Key to Illustrations: 'B' Schematic diagram

- | | |
|-----------------|---------------|
| 1 Power cable | 5 Supply unit |
| 2 Control panel | 6 Engine |
| 3 Data cable | 7 Sensor |
| 4 Junction box | |

Intentionally blank

Location of flex Electronic Components

1. General

Most of the electronic components necessary for the WECS-9520 are installed on the engine.

The power supply box E85 (not shown in Fig. 'A') is installed near the engine.

2. Control boxes

Data about the most important control boxes and power supply boxes are given as follows:

E10, E15, E20, E28:

These control boxes contain the terminals that give communication to the sensors, actuators and the remote control and the safety system.

E25:

The E25 control box is attached to the free end of the engine. The E25 has the local control panel and a WECS-9520 control panel.

E85:

The power supply box E85 is installed in the engine room near the engine. The E85 has the two 230 VAC power supplies for the FCM-20 modules, fuel pump actuators and ALM-20 modules. The E85 also has circuit breakers to isolate each FCM-20 module, fuel pump actuator and ALM-20 module.

E90 (SIB):

The E90 control box (shipyard interface box) is attached to the rail unit at the free end. The control box E90 contains the terminals that give communication to the external systems. An FCM-20 module is installed as an online spare.

E95.01 to E95.0#:

These control boxes are attached to the rail unit near their related cylinder. Each control box has an FCM-20 module.



Remark: The power supply has redundancy. If it necessary to isolate the WECS-9520, make sure that the two power supplies are set to off (for more data, see [4002-1](#) paragraph 2, and the block diagram in the control box).

E110, E120:

The alarm terminal boxes give communication to the alarm sensors and the alarm and monitoring system.

Arrangement of flex Electronic Components

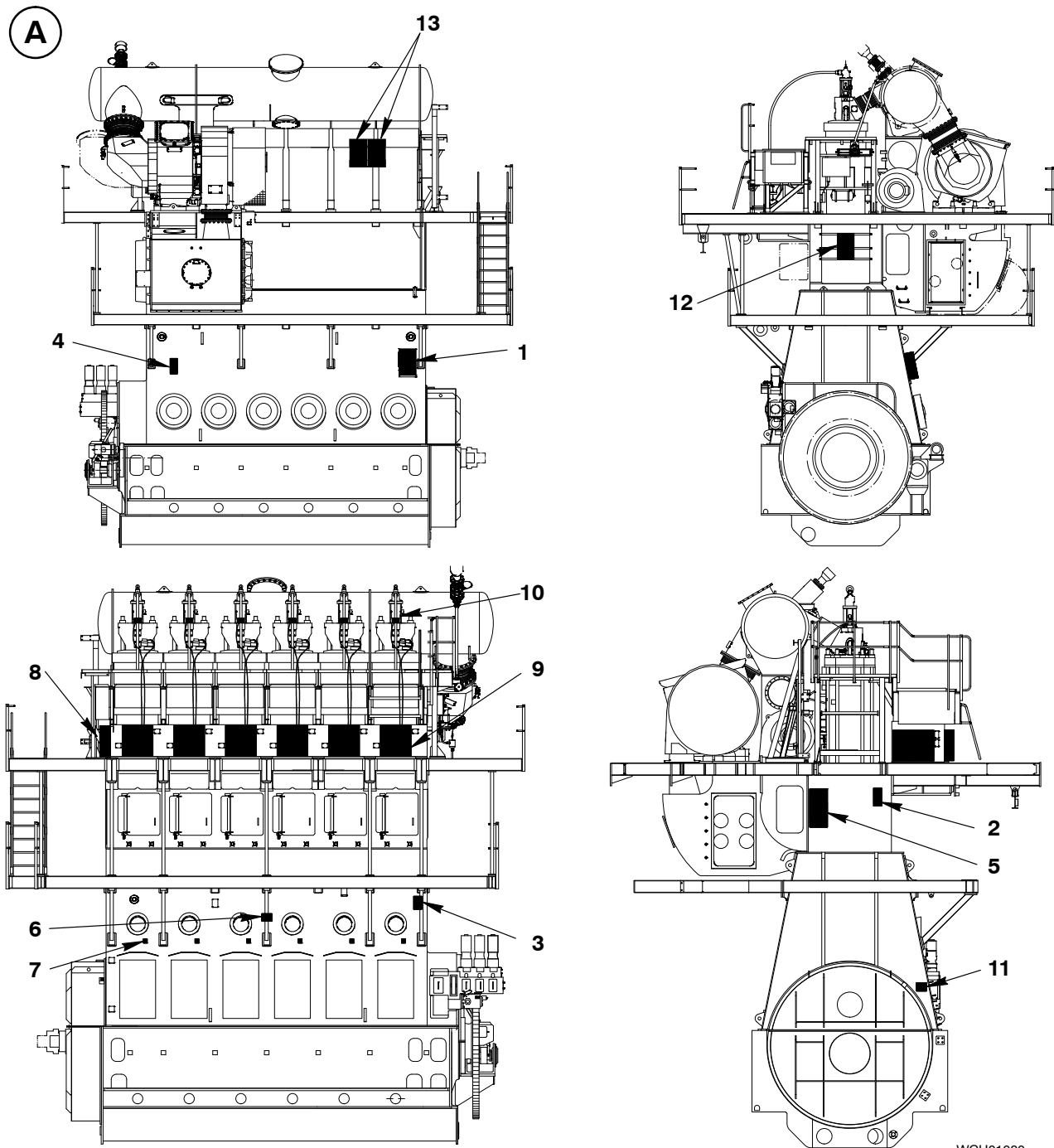
**Key to Illustrations: 'A' Location of control boxes**

- | | |
|--------------------------------|-----------------------------------|
| 1 Control box E10 | 8 Control box E90 |
| 2 Control box E12 | 9 Control box E95.01 to E95.0# |
| 3 Control box E15 | 10 Control box E95.21 to E95.2# |
| 4 Control box E20 | 11 Control box E96 |
| 5 Control box E25 | 12 Control box E110 |
| 6 Control box E28 | 13 Control box E120.1 and E120.02 |
| 7 Control box E28.01 to E28.0# | |