

X-ACT INITIATIVE

A holistic approach to sustainable shipping

WIN GD

Contents

Introduction	3
Forecasting the future	4
An ecosystem approach	5
Advanced engines	6
Core technologies	8
Green technologies	10
Digitalisation and system integration	13
The autonomous engine room	15
An X-Act fit	17

Introduction

Developing solutions for sustainable shipping requires a holistic view. Main engines for future vessels will no longer be used solely for propulsion. Instead, they will be part of an integrated energy system which in turn will be connected to other vessels, ports and even the complete transportation or logistics chain. Sustainable shipping solutions will also depend on the supply of fuels with a minimal carbon footprint, while future engines will need to be capable of using those fuels reliably, efficiently and with low emissions.

To adopt a coordinated approach to the development of sustainable shipping solutions, WinGD launched its X-Act initiative. The project aims to develop knowledge, experience and capabilities in several areas, including:

- **Advanced engine technology and portfolio**
- **Core engine development capabilities**
- **Emission reducing and efficiency increasing green technologies**
- **Digitalisation and system integration**
- **Smart technologies and autonomous shipping**

WinGD has been progressing in these areas for several years. In this paper some of the latest developments in each area are highlighted, including the latest generation of dual-fuel engine technologies, novel on-engine emission abatement systems and advances in hybrid energy system integration and control software. The X-Act initiative co-ordinates these activities with the aim of accelerating the pace at which WinGD can deliver breakthrough technologies to help ship owners decarbonise at the pace they – and, increasingly, society – demand.

Forecasting the future

What will shipping look like just one generation of vessels from today? That was WinGD's starting point for forecasting the future of ship power and propulsion in light of shipping's emission reduction ambitions. Some core assumptions emerged:

A tighter transport web: Logistics will be an increasingly connected and transparent ecosystem. This will give customers and stakeholders (including ports, ship operators and freight companies) ever greater visibility into both their own operations and those of other companies along the logistics chain.

No need for speed: In such highly integrated systems, individual vessels will require smaller speed margins. Combined with the expectation of lower average travelling speeds – for cost and efficiency reasons – this suggests that future vessels will be designed for lower speed and installed power.

Fuels will rule: Deep-sea merchant shipping will continue to be fuelled by chemical energy carriers. Electric propulsion based on storage systems fed by land-based power generation will be limited to niche applications covering short distances and with severe carrying capacity limitations. Nuclear propulsion will not be implemented widely beyond the navy sector in view of the unresolved safety concerns and lack of public acceptance.

A pick 'n' mix palette: The marine fuel and energy landscape will be varied. Fossil fuels (both liquid and gas) will play a role on older vessels and where alternatives cannot be made available quickly and easily. These will be supplemented or replaced by equivalent synthetic or biogenic drop-in fuels. Meanwhile a variety of new renewable fuels will require specifically tailored solutions. Hydrogen is not expected to become a significant part of the fuel mix in international shipping but may play a role in specific short-sea shipping applications.

A holistic approach that extends beyond WinGD's traditional role as an engine designer

An ecosystem approach

Finding solutions to fit this picture demands a coordinated effort between stakeholders. It also offers opportunities for WinGD to contribute beyond its traditional role as an engine designer. The challenge of decarbonisation and increasing efficiency has already expanded WinGD's offering.



Figure 1: WinGD's holistic approach to marine decarbonisation with an ecosystem of solutions

As well as preparing for future fuels, new engines need to be designed for integration into hybrid power arrangements, with solutions for optimising power system layout and operation. Solutions onboard vessels need to be capable of integration into larger networks so that future digital tools can offer fleet- and system-wide optimisation options. An enhanced focus on these elements is a prerequisite to offering further support and training to help ship operators master the challenges ahead of them.

The X-Act initiative highlights the interconnected development required across these areas. It is WinGD's response to industry calls for sustainability, structuring the company's efforts to deliver the high-quality, holistic solutions that ship owners and operators will need in the decades ahead.

Advanced engines

Demands for ever more powerful propulsion engines came to a halt in 2008 with the introduction of IMO's Energy Efficient Design Index (EEDI). Installed power is the single biggest factor affecting attained EEDI and, from 2023, attained EEXI for existing vessels. Significant improvements are easiest by reducing installed power.

There is another reason for designing smaller engines. Modern hull designs optimised for maximum efficiency are typically characterised by narrow aft end sections for the best fluid-dynamic performance of the hull/propeller system.

This limits the space available for engines at the aft. Engines with high stroke to bore ratios – designed for high power output at low speeds – are no longer the best solution for such vessels.

WinGD has responded to this trend by introducing the X-S model series. Available initially with bore diameters of 52cm (X52-S) and 62cm (X62-S, see Figure 2), the shorter stroke results in smaller engine dimensions.

The width of the X62-S bedplate is reduced by more than 18% compared to the conventional X62, while the overall height of the engine is decreased by about 9% and the overall engine room height can be lowered by more than 12% (i.e. about 1.5 m). The length is reduced by more than 10%, and engine weight by about 14%.

A first-of-its-kind solution in the marine market

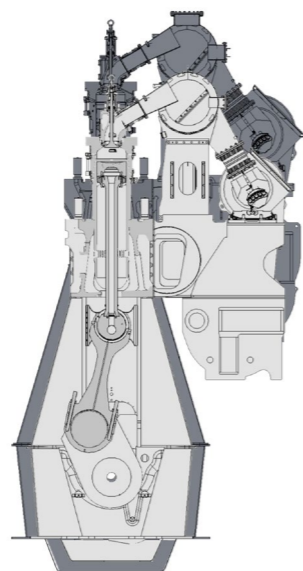

Figure 2: More compact X-S engine design compared to baseline engine

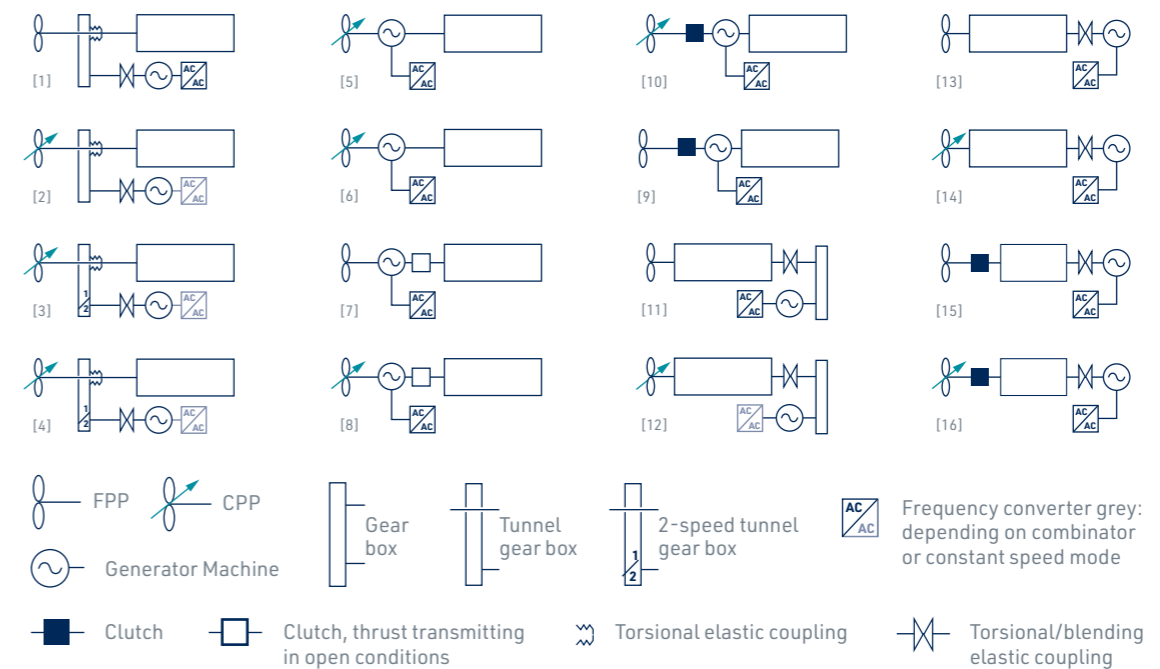

Figure 3: PTI/PTO options applicable on WinGD engines

These engines are the first designed from the outset for easy integration of advanced aftertreatment solutions. Dual-fuel models feature intelligent Control by Exhaust Recycling (iCER) technology, based on a readily available low-pressure exhaust gas recirculation system (LP-EGR). This second development stage of X-DF technology not only allows reductions of fuel consumption in both gas and diesel modes (up to 8 and 6% respectively) but also yields lower emissions of unburnt methane. Considering up to 50% reduction of methane slip and the efficiency improvements, the overall reduction of greenhouse gas emissions from the already low levels achieved with the first generation of X-DF engines amounts to almost 10%.

Diesel engine variants can be equipped with integrated Selective Catalytic Reduction (iSCR), a first-of-its-kind solution in the marine market that contributes to significantly lower space requirements in the engine room. Rather than relying on bulky, off-engine SCR systems, the iSCR is integrated in the turbocharging system of the engine, with only moderate impact on the engine's outer dimensions. Taking the X62-S as an example again, this integration increases engine height by less than 40 mm (less than 1%), without affecting the requirements for engine room height and while maintaining the same engine footprint.

Two-stroke marine engines will require a much more advanced integration with other onboard energy systems than the prime movers on most merchant marine vessels in service today. The adoption of hybridisation concepts promises important benefits in terms of overall efficiency by integrating electric power generation and propulsion systems. The availability of power-take-in (PTI) and power-take-out (PTO) technologies is an essential enabler in this context. These have been viable options for several years already and the possible external PTI/PTO arrangements in Figure 3 form an integral part of the standard documentation for WinGD engines.

Under the X-Act initiative WinGD is moving further by investigating options for integrating the PTI/PTO functionality directly on the engine. The concept is based on mounting the housing and stator of the motor/generator unit on the bedplate and column at the free end of the engine. WinGD is working with suppliers to realise the most compact solutions delivering highest possible performance.

Core technologies

Part of building better engines is building engines better. Besides the disciplines indispensable for designing and developing heavy machinery – including materials science, engineering mechanics, manufacturing and testing technology – ‘core technology’ areas also include fuel admission and combustion as well as tribology and lubrication.

Further development in these areas will enable advanced technologies to improve efficiency and minimise regulated emissions, which can then be rolled out to the product portfolio.

In recent years, WinGD has invested continuously in building competences and capacities for simulating fluid and thermodynamics, combustion, and emissions formation, as well as extending its experimental facilities. This has been integral to assessing the potential of alternative fuels, as detailed in a previous white paper, **FUTURE READY** – extending the engine research toolbox to validate clean shipping fuels.

The iCER technology mentioned above is one advance emerging from greater capabilities in core technologies. Another recent example is Variable Compression Ratio (VCR) technology, which was established in collaboration with partners from the Ishikawajima-Harima Heavy Industries (IHI) group.

VCR offers significant benefits for the overall optimisation of future engines at only moderate cost. It allows the optimum compression ratio for cylinders to be selected individually according to varying ambient conditions, fuel type and quality, and the combustion process itself. Extensive simulations have been performed to quantify these benefits and results are currently being validated in a prototype installation on a 6X72DF engine.

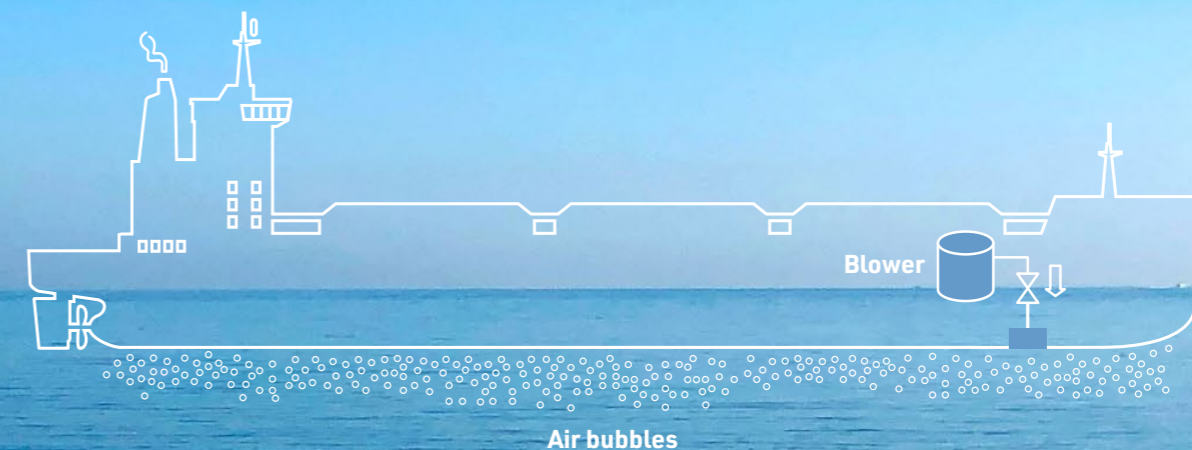

Figure 4: Air lubrication system

VCR is considered a key technology for future designs that may require even higher fuel flexibility than today's engines. It also anticipates the need for optimisation across a broader operating range due to advanced integration in overall energy systems, and it could potentially be incorporated into advanced digital solutions.

Another path towards overall optimisation is opening up for vessels applying air lubrication (shown in Figure 4). Optimisation of the turbocharging system to match both the requirements of the main engine and the air lubrication system may hold potential for maximising overall efficiency, as the associated savings in power required for the blower supplying the air lubrication may outweigh any potential fuel consumption impact on the main engine.

This benefit would come on top of the efficiency improvement associated with the reduction of hull resistance. However, the actual potential efficiency gain needs to be carefully evaluated on a case-by-case basis.

Green technologies

Decarbonisation is undoubtedly the most important target of research and development in the maritime industry. But emissions of air pollutants – including SO_x, NO_x and particulate matter – remain important and tightly regulated.

WinGD is assessing a large range of possible technical approaches for further reducing emissions of all relevant pollutants. This includes investigations into engine-internal measures as well as exhaust aftertreatment solutions. The iSCR technology mentioned previously is just one example.

Engine designers will have to **develop engines** capable of using new fuels

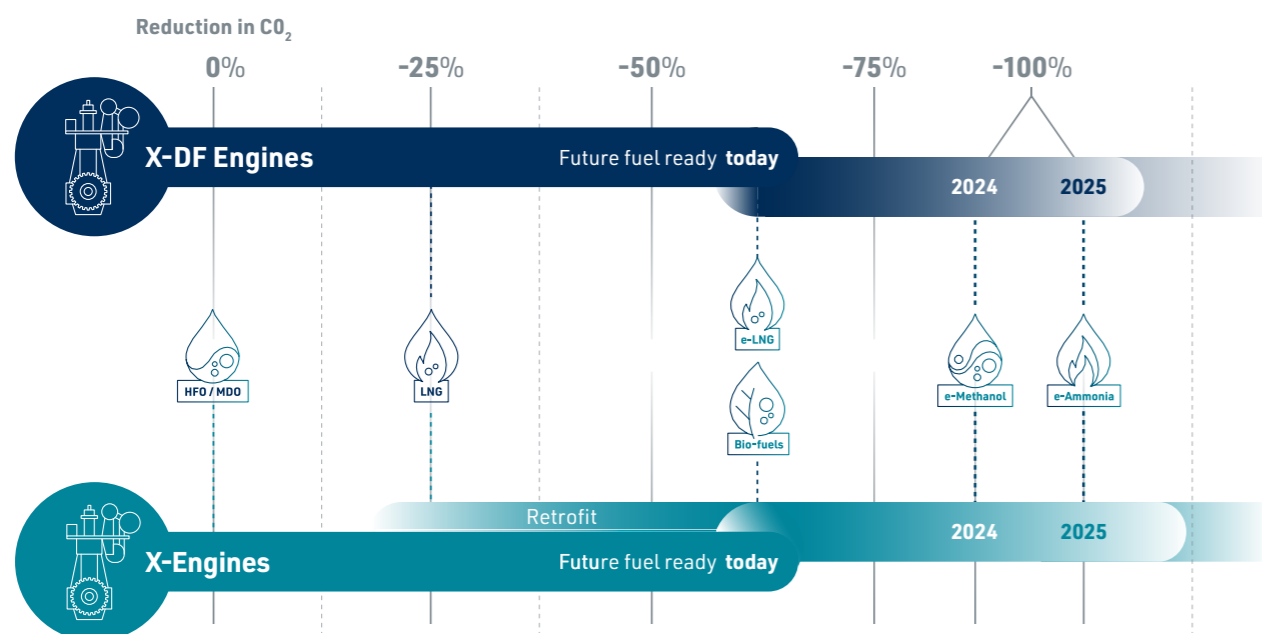

Figure 5: WinGD CO₂ reduction and future fuel technology roadmap

WinGD is also intensifying efforts to prepare its products for the more diverse fuel landscape referred to above, as highlighted in Figure 5. An important step has already been taken by the adoption of LNG as marine fuel, and the introduction of X-DF technology has served as enabler in this context.

The use of LNG has paved the way for the use of low-molecular hydrocarbons from renewable sources. Methane produced either synthetically from non-fossil feedstock using renewable energy (denoted as e-LNG in Figure 5) or from biological waste streams can already be used on existing X-DF engines without modification or precautionary measures, either on its own or blended with conventional LNG. Similar considerations apply to biofuel equivalents of conventional liquid fuels.

Use of synthetic and bio-methane will not suffice to achieve overall decarbonisation targets. Two other promising candidates are synthetic ammonia and methanol (which may also be made available as bio-fuel). Whereas ammonia is promoted by many based on its truly carbon-free nature, the methanol solution is preferred by many others due to the less pronounced concerns regarding operational safety considering, for example, the toxicity of ammonia. There is no clear winner when considering the environmental and economic benefits of fully renewable production of 'green' ammonia, methanol or methane. All are expected to exist in parallel and engine designers will have to develop engines capable of using all these fuels.

FUEL TYPE	DROP-IN CAPABLE	X-ENGINES	X-DF ENGINES
0-0.5%S VLSFO	n/a	Available	Available
HFO	n/a	Available	Available
Bio-diesel	✓	Available	Available
LNG	n/a	Retrofit	Available
Bio-methane	✓	Retrofit	Available
Synthetic methane	✓	Retrofit	Available
Ammonia	Dual-/Tri-fuel	In Development	In Development
Methanol/Ethanol	Dual-/Tri-fuel	In Development	In Development
Lignin-derived biofuel	*	Available	Available

* Under investigation

Figure 6: WinGD future fuel applicability matrix

The development of ammonia and methanol engine technology is well on track to demonstrate ammonia technology at full scale by 2025 at the latest. The demonstration of a methanol-burning multi-cylinder engine can be realised considerably earlier, by 2024 at the latest. This is due to the fact that considerable knowledge has already been accumulated in the course of the European Union's Horizon 2020 funded Hercules-2 project, culminating in the development of fuel-flexible injector technology capable of dealing with a wide range of liquid fuels from alcohols to diesel (as previously detailed in the white paper Fuel Flexible Injector).

One of the key requirements for these technologies is a high degree of modularity, to allow their application not only on new engines but also for retrofitting to existing installations with manageable effort and cost. This leads to the future fuel applicability matrix on WinGD engines shown in Figure 6.

WinGD engines can already be operated on a large variety of fuels, either by design or following retrofit. For example, X-engines designed for diesel operation can be converted to X-DF engines, allowing the use of LNG and methane from either synthetic or biogenic sources. Ammonia or methanol/ethanol-fuelled engines will likewise be available as dual- or tri-fuel engines that have either been designed for their respective fuel application from the outset or by upgrading existing X or X-DF engines.

Digitalisation and system integration

To develop digital solutions, technology developers need to be able to simulate the behavior of any element of a system so that the models can be enhanced by machine learning and other tools relying on artificial intelligence.

These 'digital twins' enable several optimisation options, for example allowing developers to assess actual performance by comparing measured operational data with real-time simulated expected values.

The same concept is applied in the WinGD integrated Digital Expert (WiDE) solution, which incorporates a digital twin of the engine and uses an engine diagnostic system (see Figure 7) to evaluate the performance of the engine. WiDE monitors the status of key components and systems, identifying deviations and analysing trends as a basis for troubleshooting as well as maintenance support.

This approach can also assist overall system optimisation. Combining digital twins of individual elements into a comprehensive model of the whole energy system allows for enhancements at various stages of integration. In the design stage, simulations of systems and operations can help identify the best system configuration. In service, a digital twin of the complete system can then be applied for the continuous optimisation of the actual operation.

Controls for the individual elements need to be integrated properly depending on the selected system components. Validation and tuning of controls can take place at an early stage in development thanks to the use of digital twins in WinGD's simulation and development toolchain. These enable ship owners to assess the build and operation of the power arrangement in digital form, simplifying the physical integration, commissioning and testing of the systems.

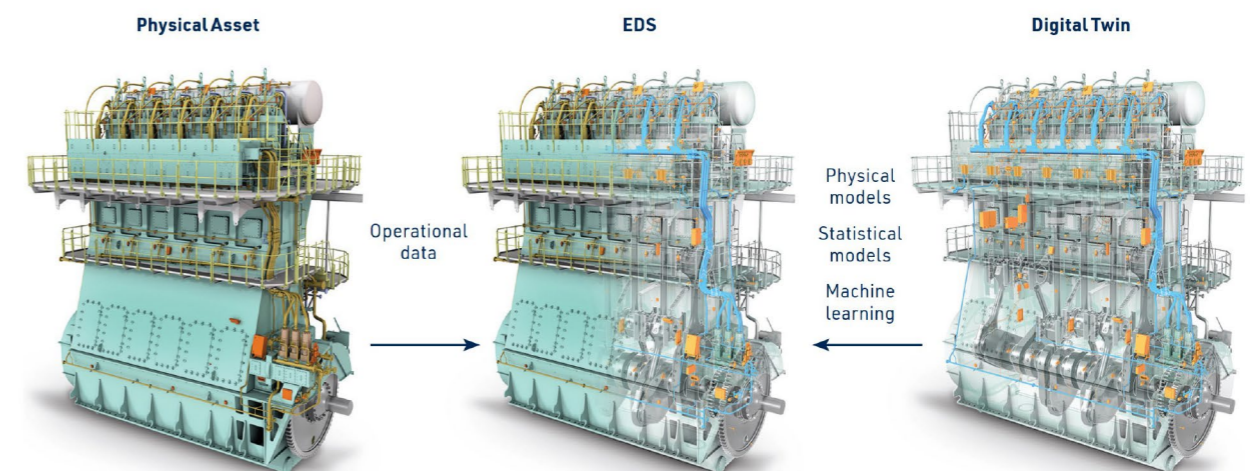

Figure 7: Working principle of the engine diagnostic system as a key building block of the WinGD integrated Digital Expert (WiDE).

The autonomous engine room

Advanced diagnostics and control systems are a prerequisite for autonomous operation of any vessel or individual system onboard. These systems must also be able to be closely integrated with parallel and higher-level systems. Figure 9 describes the 'autonomous engine room' in the context of an autonomous ship

Figure 8 shows control architecture for a hybrid system consisting of a main engine equipped with PTI/PTO, an AC grid supplied by the gensets or via on-shore power supply while at berth, both connected to a DC grid including energy storage technologies.

WinGD's offering in this context consists in both selecting optimally sized components and subsystems for any ship configuration and then operating a complete system at best possible overall performance via the hybrid control system. WinGD's development of hybrid

solutions has involved building a new team with digital and R&D skillsets; establishing a proprietary method for virtual prototyping of power arrangements; and building a dedicated energy management system that dynamically balances the use of WinGD engines and alternative power sources. The result of this investment in new technologies and processes is that WinGD can now offer power and propulsion arrangements that surpass IMO's 2030 carbon intensity targets and safeguard strong performance for the forthcoming Carbon Intensity Indicator.

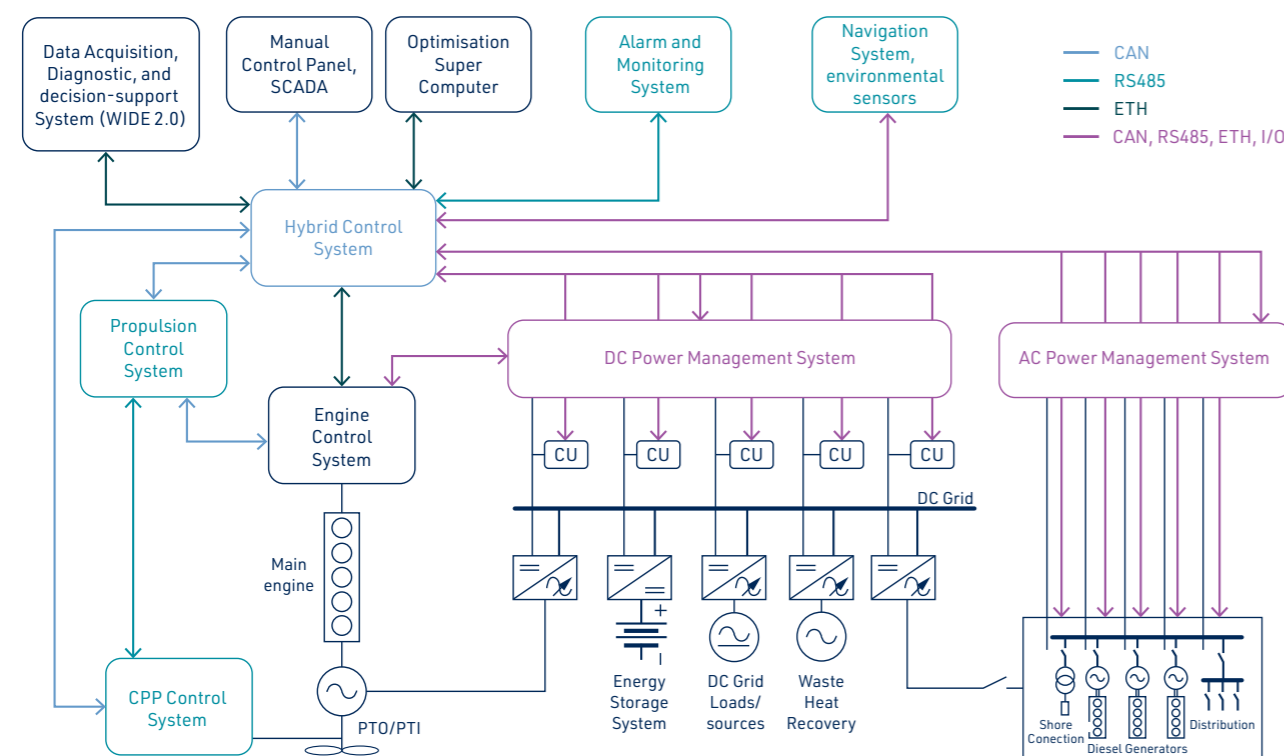

Figure 8: Hybrid solution including control system integration

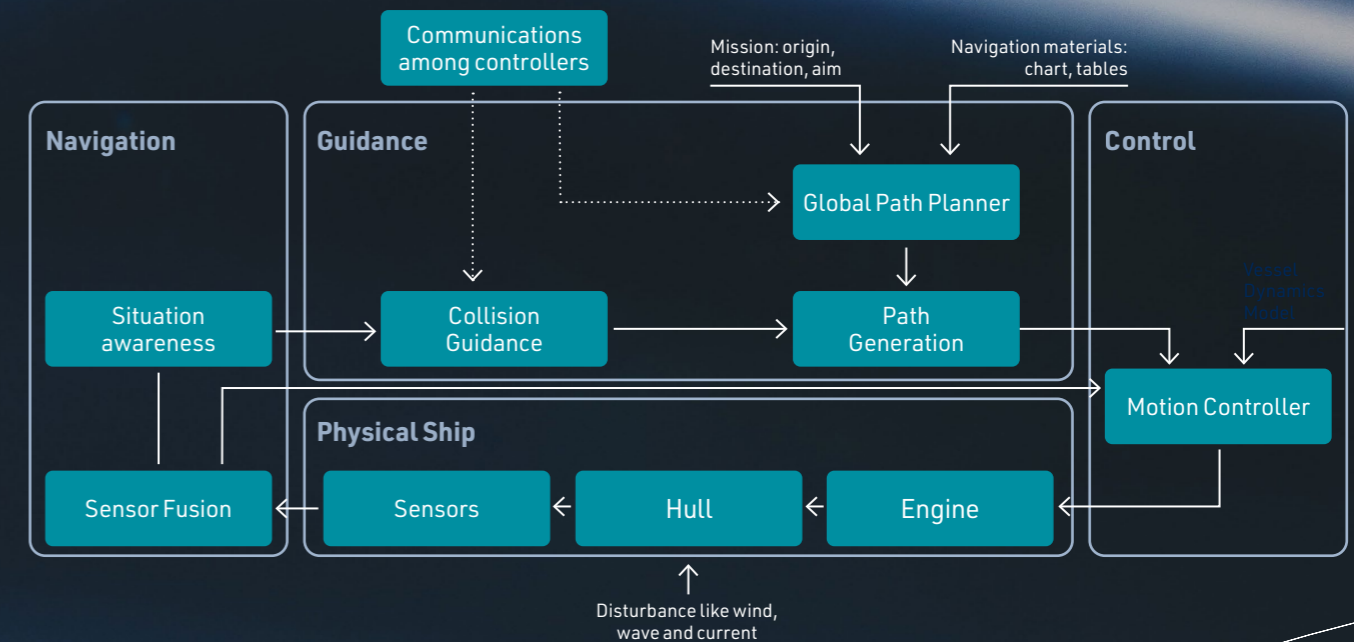

Figure 9: Autonomous engine room integration with other elements of an autonomous ship

WinGD's ambition to contribute towards the development of autonomous shipping is based on the potential seen in future smart shipping solutions. Smart engine controls and smart maintenance technologies provide direct benefit to operators. Meanwhile, the data available directly from autonomous or partially autonomous vessels, or via intermediate processing and analysis, also offers new opportunities for an engine designer. Complementing these data with own results obtained while developing, designing and validating technologies and products (see smart data infrastructure concept in Figure 10) will help WinGD to explore options for smarter design of components, key engine subsystems, engines and complete hybrid systems.

WinGD is developing smart shipping solutions for the future

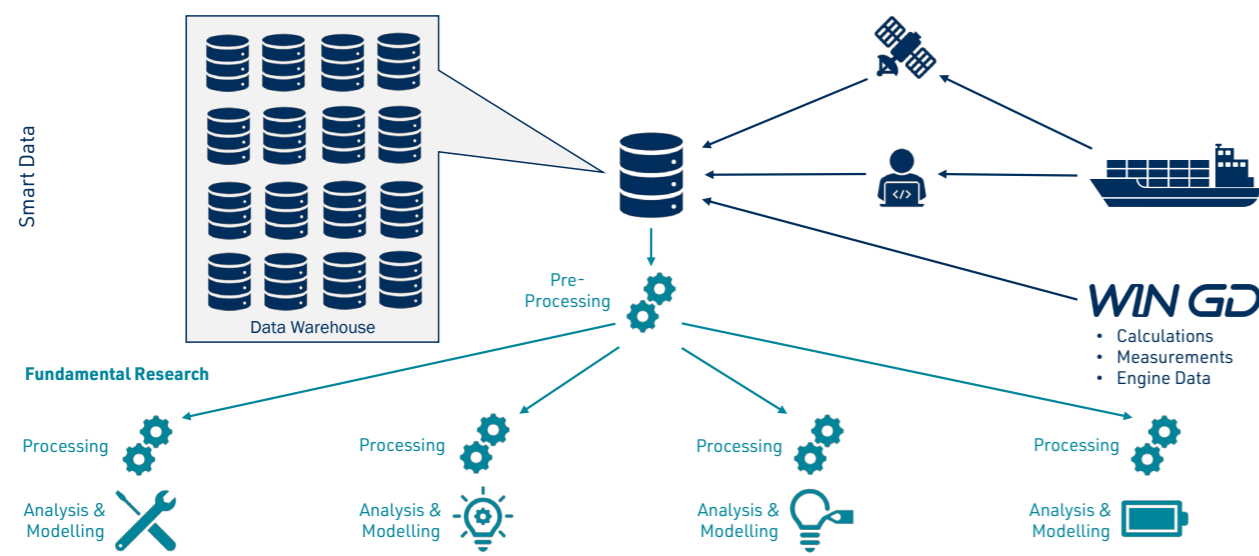

Figure 10: Smart data infrastructure concept and the interaction of the individual clusters

An X-Act fit

WinGD's X-Act initiative consolidates efforts in the largely interconnected development areas discussed in this paper (illustrated in Figure 11) into coordinated action. The continuous update of the product portfolio serves as the basis for the development in all other areas, while the enhancement of core engine development expertise and the establishment of corresponding technologies is essential for realising advanced solutions and updating the product range.

Green technologies are indispensable building blocks of future integrated and smart solutions, which in turn are a prerequisite for autonomous engine room concepts as part of any envisaged autonomous vessels. Finally, developments in all these areas are fed back into the product range, to become a part of the future, more comprehensive portfolio.

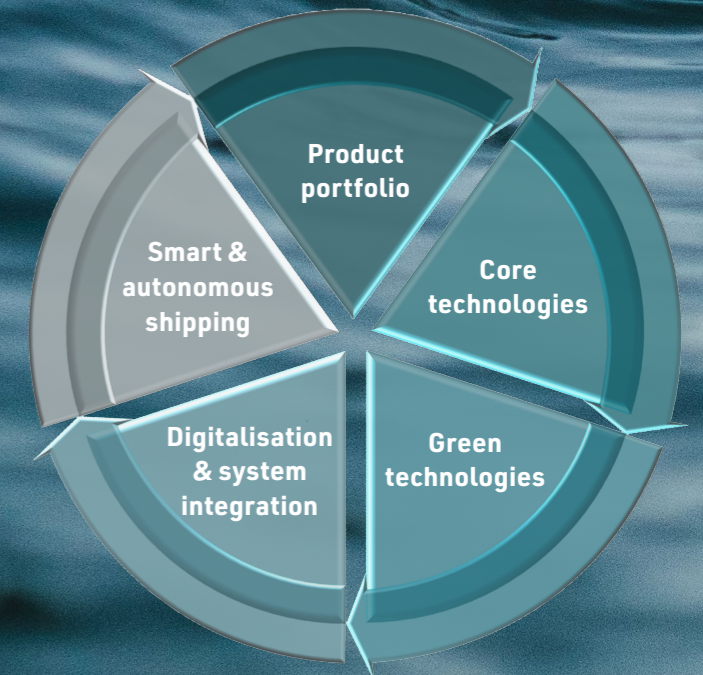

Figure 11: The WinGD X-Act initiative

The realisation of more optimised solutions required to meet the immense challenges ahead will only be possible if all shipping stakeholders tap into all possible sources of improvements. With the X-Act initiative, WinGD commits to act as this unprecedented global task demands.



WinGD® is a registered trademark
© Copyright 2022 Winterthur Gas & Diesel Ltd.

wingd.com